



## SEPTAGE TREATMENT FOR SAMBALPUR CITY



June – 2016

### **Detailed Project Report on Design, Construction, Operation and Maintenance of Septage Treatment System**

Prepared under AMRUT Mission Guidelines and SAAP – 2015-16,  
for Sambalpur City in Sambalpur District of Odisha State.

**Orissa Water Supply and Sewerage Board**

## CONTENT

|   | <b>Page</b> |
|---|-------------|
| <b><u>Part – I, Design Report</u></b>                             |             |
| 1. Introduction   | 2           |
| 2. Project Requirement  | 2           |
| 3. Project area and demand projection                             | 3           |
| 4. Design period  | 4           |
| 5. Determination of plant capacity                                | 4           |
| 6. Selection of process and review of technology options          | 6           |
| 7. Facility design of treatment components                        | 7-43        |
| 8. Component dimensioning   | 44          |
| 9. Structural Design of major components                          | 47-52       |
| <b><u>Part – II, Cost Estimates</u></b>                           |             |
| 1. Economic aspects of the project                                | 53-55       |
| 2. Cost of main components  | 56-63       |
| 3. S/R on major items   | 64-82       |
| <b><u>Part – III, Operation and Maintenance</u></b>               |             |
| 1. O&M Requirement  | 83-88       |
| 2. Manpower requirement   | 89          |
| 3. Annual O&M cost  | 89          |
| <b><u>Part – IV, GA and component drawings</u></b>                |             |
| 1. General Layout   | 90          |
| 2. Component drawings   | 91          |
| <b><u>Part – V, Bid document and contract</u></b>                 |             |
| 1. Scope of work  | 104         |
| 2. General terms and conditions                                   | 156         |
| 3. Form of contract   | 185         |
| <b><u>Appendix</u></b>  |             |
| 1. Test report on Septage characteristics (copies of test report) |             |

## **INTRODUCTION**

Atal Mission for Rejuvenation and Urban Transformation, in short, AMRUT, was launched by the Ministry of Urban Development, Govt. of India in June 2015. The objective of this new initiative is to ensure availability of basic amenities to the urbanites for improvement of quality of life. Special target groups under the mission have been the poor, disadvantaged and marginalised groups dwelling in the urban conglomerates. The basic objectives of the Mission are; (i) ensure that every household has access to a tap with assured supply of water and a sewerage connection, (ii) increase the amenity value of cities by developing greenery and well maintained open spaces (e.g. parks), (iii) reduce pollution by switching to public transport or constructing facilities for non-motorized transport (e.g. walking and cycling). The mission goals have been targeted by end of 2019-20. In order to prepare a state annual action plan (SAAP) the basic requirement is the service level improvement plan (SLIP) which shall be prepared by each of the ULBs in order to take following strategic steps in fulfilling the bare bones of AMRUT; (1) Assess the service level gap, (2) Bridge the gap, (3) Examine alternatives, (4) Estimate the cost, (5) Prioritize, (6) Out-of-box thinking, (7) Conditionalities, (8) Resilience (9) Financing and (10) Reforms.

Out of the five prioritized sectors under AMRUT, sewerage and septage management comes under priority number two. In Odisha, this sector is currently in infant stage. Only one conventional sewerage system has been established in Puri Town of 15 mld capacity aerated lagoon as the STP and with 130 kms of sewer network. The scenario in the State capital of Bhubaneswar and the historical city of Cuttack is that the conventional systems are under construction. These sewerage projects are per se slow going due to various technical reasons. These are also cost intensive i.e. around ₹15000 to 25000 per capita which has been discouraging in so far as the capital investment is concerned. As per the policy of the State, the conventional system shall be provided to the five municipal corporations. In the rest of the ULBs, the management of septage i.e. collection, transportation and treatment of faecal sludge shall be carried out which will be comparatively cheaper and also effective option for disposal of human excreta and wastewater. Also in case of municipal corporations, in the peri-urban localities, where the sewer network is not in the offing, septage management shall also be practised. Accordingly, the action plan for 2015-16 was prepared wherein 5 ULBs were selected for intervention. They are, Bhubaneswar, Cuttack, Sambalpur, Rourkela and Baripada. This report has been prepared for Sambalpur City which is a standalone package. However, the number and capacity of the septage treatment plant shall increase depending upon the population growth and effective collection and hauling network of septage through Govt. or PPP mode of operation. Though the approach is currently top down, the ultimate objective of the project is to have a participatory approach with community involvement in the collection, hauling, treatment and end use of the septage thus moving towards a hygienic and cleaner environment.

## PROJECT DEVELOPMENT PLAN FOR SAMBALPUR CITY ON SEPTAGE TREATMENT

As per the 2011 census, the population of Sambalpur City is 1.855 Lakh. The decennial growth rate of the city is @ 20%. The population of the out growth area is about 0.06 Lakh. The average floating population is about 15,000. Both horizontal and vertical growth of the city is observed during the recent years. Satellite towns are developing in the outskirts of the city. Sambalpur symbolizes the culture of western Odisha with the famous Sambalpuri folk dance. The city is also famous for its unique handloom (Sambalpuri Silk Saree) and the fabric. There is presence of a major multi-purpose reservoir and dam (longest earthen dam of Asia) over river *Mahanadi*. Mahanadi Coalfields Ltd. (MCL), the major coal producer and HINDALCO are also present in Sambalpur. Economy of the city is based on industrial activities in the periphery, whole sale trading and support services.

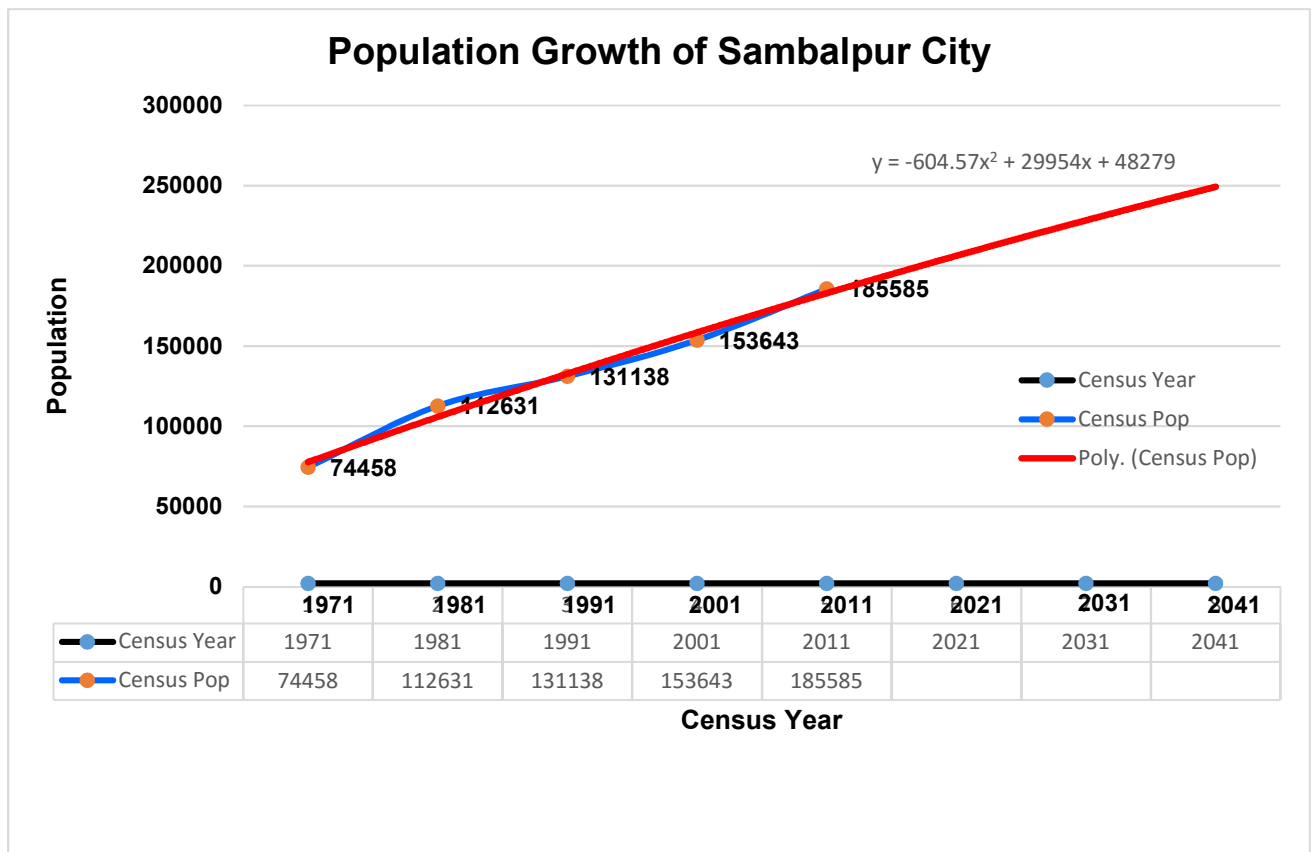

Fig: 1 Projected Population of Sambalpur for the design period of 20 years starting from 2017

The plotted graph with available data shows the 'S' pattern. A polynomial of order 2 trend line was found to be most fitting considering the growth pattern in the last five decades. The observed decadal growth rate is around 20%;

$$71-81: (112631 - 74458) / 74458 = 0.5127 \text{ i.e. } 51.27\%$$

$$81-91: (131138 - 112631) / 112631 = 0.1643 \text{ i.e. } 16.43\%$$

$$91-01: (153643 - 131138) / 131138 = 0.1716 \text{ i.e. } 17.16\%$$

$$01-11: (185585 - 153643) / 153643 = 0.2079 \text{ i.e. } 20.79\%$$

The trend line analysis provides a growth equation:  $y(\text{pop}) = -604.57x^2 + 29954x + 48279$  on a poly series of 2<sup>nd</sup> order. Using this equation, the projected population for next two decades for Sambalpur City alone are as follows;

$$2021: -604.57 \times 6^2 + 29954 \times 6 + 48279 = 2,06,238$$

$$2031: -604.57 \times 7^2 + 29954 \times 7 + 48279 = 2,28,333$$

$$2041: -604.57 \times 8^2 + 29954 \times 8 + 48279 = 2,49,219$$

The predicted average growth rate for the decades up to 2041 works out to 9.93% subject to the condition that no additional areas are included under the municipal limits. Though this is lesser than the growth trend between 2001 and 2011, the falling trend in the rate of growth since 1971 may justify the above average. The plant capacity determined on the basis of population shall not be restricted and provisions for capacity augmentation shall be made on the actual demand pattern under a 10 years' phase.

#### DESIGN PERIOD:

The plant design period is considered as 20 years since the service life of all major structural components shall a lifecycle period of 20 years. However, in order to reduce the capital expenditure, the capacity can be phased by 10 years each so that a second system is built after 10 years of service of the initial one.

Considering the year of implementation as 2016, the population to be served at the beginning i.e. 2017, after 10 years shall have to be estimated. For the next 10 years depending upon the actual growth pattern of the population, development of the on-site sanitation system within the municipal boundaries, growth of commercial and other institutions, who can contribute to the net demand shall have to be worked out before the end of the service period. In other words, full capacity utilisation of the first plant setup is to be achieved and thereafter capacity augmentation can be made with appropriate modification of the facilities. Hence, in this analysis a demand period of 10 years and a service period of 20 years at full capacity after 10 years has been considered.

The projected population for the year 2017 using the above relation comes to 2,17,437 and population at the end of the period 2027 comes to 2,38,927.

#### DETERMINATION OF PLANT CAPACITY:

Plant capacity is dependent upon the volume of sludge that is likely to be produced during the design period. The initial plant loading shall be based on the population contribution at the beginning i.e. during the year 2017 and shall increase @ 1% annually.

The design flow can be determined in two different considerations. One is based on the on-site system that is actually existing and likely to be constructed through enforcement of pollution control law / rule with regard to discharge of sewage / wastewater to open environment by the households. The other one is based on the contribution directly by the population. In any case the demand or generation of sludge shall remain highly fluctuating throughout the service period of the facility. Similarly, collection of the entire faecal sludge or septage that is generated may not be possible due to difficulty in approach, unwillingness of the housekeeper or badly designed on-site system. Therefore, a reasonably accurate quantification of the sludge production may not be possible under the present scenario of urbanisation in Sambalpur. Based on observation in various projects undertaken worldwide certain logic has been developed as discussed in the literature review part of this DPR and this shall be applied in this case to determine, with a fair degree of accuracy, the volume of septage that is likely to be handled during the service period of the plant i.e. reaching the full capacity within 10 years and operating with the full capacity with an allowable over capacity for the rest 10 years of its effective service life. A contributory population of 20% is considered for septage generation and treatment i.e.  $217437 \times 0.2 = 43487$

Though the ultimate aim is to deliver all septage or faecal sludge that is produced, it is unrealistic to assume that all so produced shall be collected and transported initially to the SeTP for treatment. Hence a reasonable quantity is required to be derived. Based on observation it has been found that for the urban areas of developing countries and as reported by Sasse, 1998, the sludge production can be in a range of 360 to 500 litres per capita per annum. Considering reduction in volume due to primary treatment through anaerobic digestion in septic tanks and also due to combination of comparatively fresh sludge from public toilets, a value of 150 litres per capita per annum may be reasonably accurate.

Sludge quantification:

1. Estimated per capita annual sludge generation as septage: **150 l / per capita / year**
2. Percentage of septic tanks that are de-sludgable: 60 to 80%
3. Estimated annual septage generated:  $0.6 \times (43487) \times 0.15 = 3914 \text{ m}^3$
4. Total considering 20% from commercial and institutional supply:  $4697 \text{ m}^3$
5. Considering 6 days a week, for 280 working days, daily volume:  $16.77 \text{ m}^3$
6. Considering a growth rate of 1% per annum, the sludge volume to be handled per day shall be:

| Year 0              | Year 1              | Year 2              | Year 3              | Year 4              | Year 5              | Year 6              | Year 7              | Year 8              | Year 9              |
|---------------------|---------------------|---------------------|---------------------|---------------------|---------------------|---------------------|---------------------|---------------------|---------------------|
| 16.8 m <sup>3</sup> | 17.0 m <sup>3</sup> | 17.1 m <sup>3</sup> | 17.3 m <sup>3</sup> | 17.5 m <sup>3</sup> | 17.7 m <sup>3</sup> | 17.8 m <sup>3</sup> | 18.0 m <sup>3</sup> | 18.2 m <sup>3</sup> | 18.4 m <sup>3</sup> |

We shall consider a daily design load of  $20 \text{ m}^3$

**Treatment combination:**

Inlet channel + Bar screen + Settling-Thickening Tank + Hybrid ABR + HF + M Pond + Unplanted Drying Bed

**Inlet Channel:**



Fig 2: A typical manual screen channel in the septage plant. (Source: Linda Strande)

A typical configuration of inlet channel is shown above. Since the faecal sludge / septage shall be discharged from a cesspool emptier truck, a receiving pit with an inlet channel is required for offloading the septage to the settler cum equalizer tank for further treatment. The channel should have adequate hydraulic properties to carry the slurry / liquid sludge without deposition in the channel and the bar screen should be able to separate the floating solids from the sludge. The channels should be built in duplicate (two channels) for alternate cleaning and loading operations.

**FACILITY DESIGN OF INLET CHANNEL (Hydraulic Capacity):**

The inlet channel shall precede by one 1m x 1m size RCC header pit. The total depth of the channel shall be kept 1 m and length 3 m. A slope of 1% may be provided towards the bar screen inlet of the settling cum thickening tank. The length of channel may vary depending upon the loading point and the settling tank location.

Emptying time of one truck of 3000 litres capacity = 10 minutes

Discharge = 5 lps = 0.005 m<sup>3</sup>/s

A channel width of 300 mm is considered = b

Adopt Manning's 'n' = 0.014 (concrete with surface punning)

Using Manning's equation, the section factor  $AR^{2/3} = n \times Q / \sqrt{S} = 0.014 \times 0.005 / \sqrt{(0.01)} = 0.007$

Considering a rectangular section: hydraulic radius =  $(by / b + 2y)$

$$AR^{2/3} = (by)^{5/3} / (b+2y)^{2/3} = 0.007$$

$$\Rightarrow (0.3y)^{5/3} / (0.3 + 2y)^{2/3} = 0.007, \text{ solving the equation for } y,$$

$$\Rightarrow y = 0.15 \text{ m or } 150 \text{ mm} = \text{depth of flow (OK)}$$

$$A_w = \text{wetted area} = 0.045 \text{ m}^2, \text{ wetted perimeter, } P_w = 0.6 \text{ m}$$

$$V = \text{velocity of flow in discharge channel} = (1/0.014) \times (0.045/0.6)^{0.67} \times (0.01)^{0.5}$$

$$\Rightarrow \mathbf{1.26 \text{ m/sec} > 0.8 \text{ m/sec (OK)}}$$

### **Bar Screen:**

A course bar screen made of stainless steel of 316 grade with 20 mm spacing shall be provided at an angle of 135° to the direction of flow or 45° to the vertical. The screen shall be placed in chamber of 1.0 m x 1.0 m wide facing the sludge channel.

### **Settling and thickening Tank:**

#### **Design and Operational principles of settling and thickening tanks:**

Settling-thickening tanks are used to achieve separation of the liquid and solid fractions of faecal sludge / septage. They were first developed for primary wastewater treatment, and for clarification following secondary wastewater treatment, and it is the same mechanism for solids-liquid separation as that employed in septic tanks. Settling-thickening tanks for FS / septage treatment are rectangular tanks, where FS is discharged into an inlet at the top of one side and the supernatant exits through an outlet situated at the opposite side, while settled solids are retained at the bottom of the tank, and scum floats on the surface (Figure 3). During the retention time, the heavier particles settle out and thicken at the bottom of the tank as a result of gravitational forces. Lighter particles, such as fats, oils and grease, float to the top of the tank. As solids are collected at the bottom of the tank, the liquid supernatant is discharged through the outlet. Quiescent hydraulic flows are required, as the designed rates of settling, thickening and flotation will not occur with turbulent flows. Baffles can be used to help avoid turbulence at the inflow, and to separate the scum and thickened sludge layers from the supernatant.

Following settling-thickening, the liquid and solid fractions of FS or septage require further treatment depending on their final fate, as the liquid and solids streams are still high in pathogens, and the sludge has not yet been stabilised or fully dewatered. Settling-thickening tanks can be used in any climate, but are especially beneficial when treating FS or septage with a relatively low solids concentration, and/or in temperate or rainy climates. This is an important consideration in urban locations where space is limited, as it can reduce the required area of subsequent treatment steps. For instance, achieving solids-liquid separation in settling-thickening tanks prior to dewatering with drying beds reduces the required treatment area (footprint) for drying beds.



When using settling-thickening tanks there should be at least two parallel streams to allow for an entire operational cycle of loading, maintenance and sludge removal. For increased sludge compaction and ease of operations and maintenance, tanks should not be loaded during compaction, if the sludge is left to thicken at the bottom of the tank, or during the desludging period, when the supernatant is drained and the scum and thickened sludge are removed. Tanks are usually operated with loading periods ranging from one week to one month, depending on the tank volume. When operated in parallel, each tank is only loaded 50% of the time.

In most existing implementations in low-income countries, the sludge removal is done with backhoes / excavator, pumps if the sludge is not too thick to pump, or strong vacuum trucks. On the other hand, in wastewater treatment plants clarifiers typically include mechanical devices to remove the settled sludge from the tank.

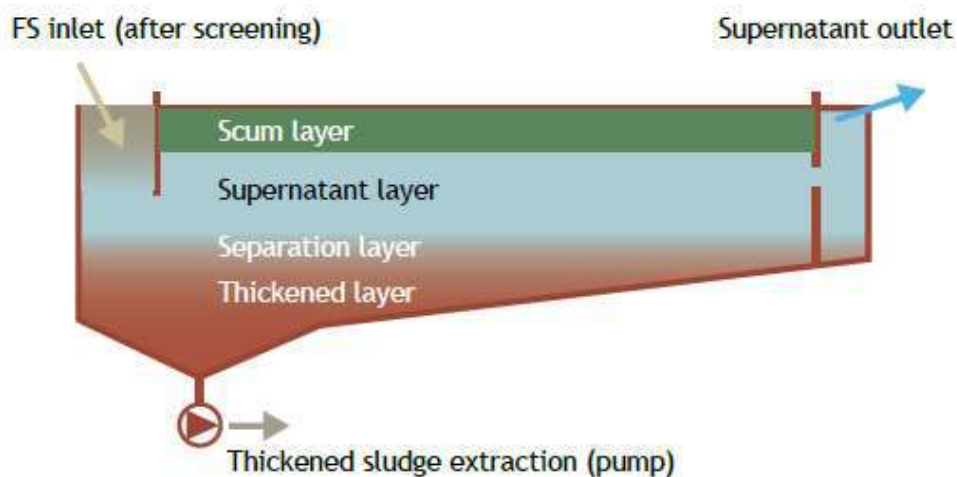

Figure 3: Schematic of the zones in a settling-thickening tank. (source: Magalie Bassan *et al.*)

The system subsumes three processes i.e. settling, thickening and floatation. Though anaerobic digestion also takes place but the same is not included as a treatment goal since it can hinder solid-liquid separation due to gas bubbles produced under anaerobic digestion process.

#### Settling mechanism:

In settling-thickening tanks the suspended solid (SS) particles that are heavier than water settle out in the bottom of the tank through gravitational sedimentation. The types of settling that occur are:

- discrete, where particles settle independently of each other;
- flocculent, where accelerated settling due to aggregation occurs; and
- hindered, where settling is reduced due to the high concentration of particles (Ramalho, 1977).

Discrete and flocculent settling happen rapidly in the tank. Hindered settling occurs above the layer of sludge that accumulates at the bottom of the tank, where the suspended solids concentration is

higher. These combined processes result in a reduction of the solids concentration in the supernatant, and an accumulation of solids at the bottom of the tank.

Particles with a greater density settle faster than particles with lower densities. Based on the fundamentals of settling the distribution of types and shapes of particles in FS (and their respective settling velocities) could theoretically be used to design settling-thickening tanks. Although this theory is important in understanding the design of settling-thickening tanks, the reality is that when designing a settling tank, empirical values are determined and used for the design based on the characteristics of the FS in specific conditions.

The theoretical settling velocity of a particle is given by Equation 20. It is defined by the velocity attained by a particle settling in the tank as the gravitational strength overcomes the buoyancy and drag force that retain the particle in the top layer of the tank.

**Equation 1:**  $V_c = [(4/3) \cdot g (\rho_s - \rho) d / C_d \rho]^{1/2}$

Where:

$V_c$  = final settling velocity of the particle (m/h)

$g$  = gravitational acceleration ( $m/s^2$ )

$\rho_s$  = particle density (g/L)

$\rho$  = fluid density (g/L)

$d$  = particle diameter (m)

$C_d$  = drag coefficient

The critical settling velocity,  $V_c$ , is selected based on the amount of solids that are to be removed. Theoretically, if the flow is laminar (i.e. not turbulent) and there is no shortcutting of the hydraulic flow in the tank, all the particles with a velocity greater than  $V_c$  will be removed. This allows the tank to be designed based on the percentage of desired particle removal in the settled sludge. As the flow in the tank is lengthwise, the length has to be designed to be long enough to ensure that particles with  $V_c$  have adequate time to settle out below the level of the outlet. Particles with  $V_c < V_{c0}$  will not have time to settle out, and will remain suspended in the effluent (as shown in Figure 4). Selection of  $V_c$  for actual design purposes is discussed in paras to follow.

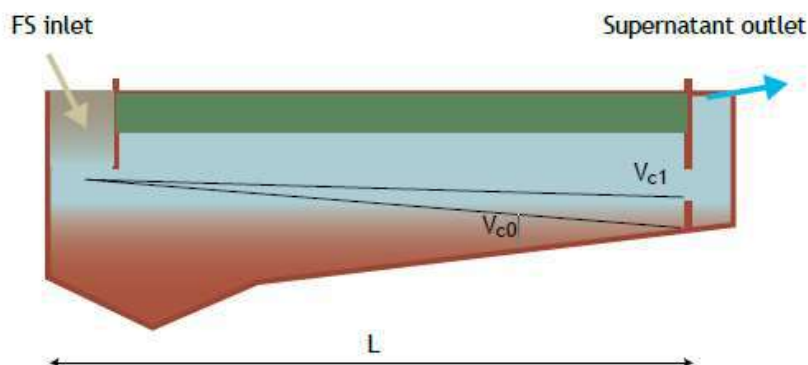

Figure 4: Schematic of the final settling velocity ( $V_c$ ) needed for a particle to settle in a tank of length  $L$ . (source: Magalie Bassan *et al.*)

### Thickening

Particles that accumulate at the bottom of the tank are further compressed through the process of thickening. The settled particles are compressed due to the weight of other particles pressing down on them, and water is squeezed out, effectively increasing the concentration of the total solids. This happens as a result of gravity, when the concentration of SS is high and inter-particle strengths hinder the individual movement of particles. Allowing room in the tank for sludge storage as it settles and accumulates is an important consideration in the design of tanks, because as sludge accumulates, it effectively reduces the depth of the tank available for settling. This is also important in designing the ongoing operations and maintenance, and schedule for sludge removal.

### Flotation

The process has already been described in brevity at page 8 under fundamental mechanism. It is repeated here to maintain the flow of description. As stated earlier, similar to the settling and thickening mechanisms, the influence of gravitational strength due to density differences explains flotation. Buoyancy is the upward force from the density of the fluid. For particles that float, the buoyancy is greater than the gravitational force on the particle. Hydrophobic particles such as fats, oils and greases, and particles with a lower density than water are raised to the top surface of the tank by flotation. Some particles are also raised to the surface by gas bubbles resulting from anaerobic digestion. This layer that accumulates at the top of the tank is referred to as the scum layer.

### Anaerobic digestion

Anaerobic digestion also occurs in settling-thickening tanks, mainly in the thickened layer. The level of digestion depends on the degree of the initial stabilisation of FS / septage, the temperature, and on the retention time inside the tank. This process degrades a part of the organic matter and generates gasses. Operational experience has shown that fresh FS that is not stabilised (e.g. from public toilets that are emptied frequently) does not settle well. This is because anaerobic digestion of fresh FS contributes to an increased up-flow from gas bubbles, and FS that is not stabilised also contains more bound water. Thus, stabilised FS, especially the septage i.e. sludge from septic tanks and/or FS that is a mixture of stabilised and fresh sludge are more appropriate for treatment in settling-thickening tanks (Heinss *et al.*, 1998; Vonwiller, 2007).

### Solids-liquid zones

The interactions of these fundamental mechanisms result in the separation of the FS into four layers, as illustrated in Figure 6.1 (Heinss *et al.*, 1998; Metcalf and Eddy, 2003):

- A layer of thickened sludge at the bottom. The solid concentration is higher at the bottom than at the top of this layer.
- A separation layer between the thickened layer and the supernatant, as the transition between these is not immediate. Hindered settling occurs mainly in the separation layer, where the settled sludge is not completely thickened. Particles in the separation layer can be more easily washed out with the supernatant than particles in the thickened layer.
- A supernatant layer between the separation layer and the scum layer. This consists of the liquid fraction and the particles that do not settle out or float to the surface.
- A layer of scum at the top of the tank. This consists of the floating organic and non-organic matter, the fats, oils, and greases contained in FS, as well as particles that have been raised up by gas up-flow.

The tank design is based on the estimated volume of FS, and the resulting supernatant flow, and production of scum and thickened sludge layers. An adequate design needs to include regular and efficient removal of the scum and thickened sludge, which needs to be considered to optimise the solids-liquid separation. These design aspects are discussed below, and examples are provided in the case studies and the design example.

#### Laboratory tests and faecal sludge characteristics influencing the design

A good understanding of site specific FS characteristics is required in order to determine the tank surface and the volume of the scum, supernatant, separation, and thickened sludge layers. determining an accurate value for influent loading of FS can be challenging depending on the local infrastructure and existing management system. The design loading needs to take into account that FS quantities and characteristics can also vary seasonally. An empirical estimation of settling ability for the specific FS for which the tank is being designed for, needs to be determined for adequacy in the design of the tank. Preliminary laboratory analysis should be conducted on the FS that is to be treated, especially in terms of settling ability, thickening ability, potential for scum accumulation and SS concentration (Strauss *et al.*, 2000). It is important to ensure that the FS used for these tests is that which will actually be treated. For example, if there is an existing network of collection and transport companies with vacuum trucks, sludge should be sampled from the trucks as this is what will be discharged at the treatment plant.



Figure 5: Imhoff cones being used in analyses of sludge volume index (source: SANDEC).

The sludge volume index (SVI) is a laboratory method to empirically determine the settling ability of sludge based on the amount of suspended solids that settle out during a specified amount of time. To determine the SVI, first the suspended solids content of FS is determined, and then a graduated Imhoff cone is filled with the FS sample that is left to settle (see Figure 6.4). After 30-60 minutes, the volume occupied by the settled FS is recorded in mL/L. The SVI is then calculated by dividing the volume of settled FS by the SS concentration (in g/L), which gives the volume of settled sludge per gram of solids. The Imhoff tests do not provide exact estimates of the depth of the thickened layer, as they are batch tests and not continuous loading as in a settling-thickening tank. Imhoff cones with volumes greater than one litre provide a more representative result as the wall effect is reduced (Heinss *et al.*, 1999).

Based on experiences in the design of settling-thickening tanks for wastewater treatment plants, wastewater sludge with a SVI of less than 100 (mL/g SS) achieves good solids-liquid separation in settling-thickening tanks. Measurements with FS in Accra, Ghana and Dakar, Senegal showed that FS had a good settling ability and thickening ability with SVI of 30-80 mL/g (Heinss *et al.*, 1998), and the personal experience of Dodane). SVI tests conducted in Dakar, Senegal (Africa) showed that FS settled rapidly during the first 20 minutes, after which more thickening occurred and continued for 100 minutes (Badji *et al.*, 2011).

#### Tank surface and length:

The length of the tank needs to be sufficient and have adequate hydraulic distribution, to ensure that the entire tank surface area is used, and that particles have enough time to settle. The surface area of the settling-thickening tank can be calculated as shown in Equation 2, based on the up-flow velocity ( $V_u$ ) and the influent flow ( $Q_p$ ) (Metcalf and Eddy, 2003).

**Equation 2:**  $S = Q_p / V_u$

Where:

S = surface of the tank (m<sup>2</sup>)

Q<sub>p</sub> = influent peak flow (m<sup>3</sup>/h)

V<sub>u</sub> = up-flow velocity (m/h)

Q<sub>p</sub> = Q . C<sub>p</sub>/h,

Where:

Q = mean daily influent flow

C<sub>p</sub> = peak coefficient

h = number of operating hours of the treatment plant (influent is only received during operating hours)

The up-flow velocity ( $V_u$ ) is defined as “the settling velocity of a particle that settles through a distance exactly equal to the effective depth of the tank during the theoretical detention period” (Ramalho, 1977). It is used to calculate the acceptable inflow that will allow for particles with the defined settling velocity to settle out. Particles with a settling velocity slower than  $V_u$  will be washed out with the

supernatant. A design value is selected for the desired percentage of suspended solids removal, and then the design up-flow velocity is selected to be equal to the final settling velocity of the lightest particles that will settle in the tank. For example, as shown in Figure 3,  $V_u = V_{c0} > V_{c1}$ . Thus, for a given FS influent, the up-flow velocity in a tank surface corresponds to the removal of a given percentage of suspended solids.

The peak coefficient is calculated by observation of when the greatest volumes of trucks are discharging at the FSTP / SeTP. For example, in Dakar, (Senegal, Africa) the peak period was observed to be 11:00 because trucks have their busiest emptying periods during the morning, and was calculated to be 1.6 times higher than the average.

Now,  $V_u$  can be estimated based on SVI values. Despite the limits of the theoretical calculation for design purposes, methods and calculations to link SVI and  $V_u$  have been developed based on long-term experiences in activated sludge treatment (Pujol *et al.*, 1990). However, this type of empirical knowledge does not yet exist for FS.  $V_u = 0.5$  m/h could be used for rectangular settling tanks treating FS that have a SVI less than 100 (Megalie Bassan and Pierre-Henri Dodane). Once the surface area has been calculated, the length to width ratio needs to be selected. For example, (Heinss *et al.*, 1998) recommend a width to length ratio between 1:10 to 1:5. The lower the selected final settling velocity, the longer the tank needs to be, and the more particles that will settle out.

### Tank volume

Once the surface area of the tank has been determined, the volume can be calculated, considering the depth of the four layers described in Figure 3. It is necessary to plan for the reduction in depth that will occur due to the accumulation of scum and thickened sludge, which will result in solids washed out with the supernatant, if underestimated.

Based on field observations of settling-thickening tanks in Accra and Dakar (Heinss *et al.*, 1998), the following values are recommended for designing tanks for FS / septage with similar characteristics:

- scum zone: 0.4 m (with 1 week loading, 1 weeks' compaction and cleaning) to 0.8 m (with 4 weeks loading and 4 weeks' compaction and cleaning);
- supernatant zone: 0.5 m; and
- separation zone: 0.5 m.

The depth of the thickened sludge zone needs to be calculated given the expected load inflow and the concentration of the thickened sludge ( $C_t$ ). The design of a sufficient storage volume for the thickened sludge is crucial to avoid outflow of settled sludge during one operating cycle. Therefore, the expected operating cycle duration (i.e. loading, compaction and sludge removal) and methods for scum and thickened sludge removal need to be defined in the first place. The volume of the thickened sludge storage zone ( $V_t$ ) can be calculated as shown in Equation 2 (Metcalf and Eddy, 2003).

**Equation 3:**  $V_t = Q.C_i.e.N / C_t$

Where:

$V_t$  = volume of thickened sludge storage zone (m<sup>3</sup>)

$Q$  = mean FS daily inlet flow (m<sup>3</sup>/day).

$C_i$  = suspended solids mean concentration of FS load (g/L)

$e$  = expected settling efficiency (= proportion of suspended solids separated, as %)

$N$  = duration of the FS load for one cycle in days

$C_t$  = suspended solids mean concentration of thickened sludge after the loading period (g/L)

The mean daily flow is used for the sludge accumulation estimate, but the peak flow is used for the tank surface and length design to ensure settling is achieved under all the expected operating conditions. The volume of the thickening zone is based on the expected settling of FS. It is not considered in the design, but longer storage times when the tanks are not loaded prior to sludge removal, result in increased thickening and compaction. In the field, average FS settling efficiencies of only about 60% have been observed, due to poor operation and maintenance and gas up-flow (Heinss *et al.*, 1998). However, it is recommended to use 80% to estimate the maximum efficiency.

Care must be taken to ensure a relatively accurate estimate of  $C_t$ . An overestimation will lead to an insufficient storage volume and to a reduced settling efficiency, as solids may be washed out without being able to settle. An underestimation will lead to the design of an unnecessarily large storage volume and increase in construction costs.

Table 1 presents examples of SS concentrations given the initial FS load and thickening duration.

| Place of measurement | Concentration at inlet<br>(g SS/L) | Thickening duration<br>(day) | Concentration in thickened zone<br>(g SS/L) |
|----------------------|------------------------------------|------------------------------|---|
| Dakar, FSTP          | 5                                  | 10                           | 60-70                                       |
| Accra, FSTP          | 15-20                              | 9                            | 60-85                                       |
| Accra, FSTP          | 15-20                              | 30                           | >100  |
| Accra, FSTP          | 15-20                              | 50                           | 140   |
| Accra, laboratory    | 40                                 | 7                            | 100   |

Table 1 Concentration of sludge in the thickening zone of settling tanks in Accra and Dakar (Source: Heinss *et al.*, 1998; Badji *et al.*, 2011)

Inlet and outlet configuration

Grit screening must be undertaken before the loading of FS into the settling-thickening tanks in order to facilitate maintenance (e.g. removal of coarse waste to avoid potential damage to pumps).

The inlet zone should allow for the uniform and quiescent distribution of the flow in the whole tank and avoid short-circuiting. Therefore, baffles are recommended to help disperse the energy of the inflow, and to reduce the turbulence in the tanks. (Heinss *et al.*, 1998) recommend locating the inlet zone near the deep end of tanks to improve the solids settling. The pumps for the extraction of the thickened sludge must be adapted to remove concentrated sludge. Easy access points should also be included to allow the sampling of sludge in these zones, and to ensure that easy repair of pumps is possible.

The supernatant outlet zone should be located under the scum layer and above the thickened sludge storage layer. Baffles are useful to avoid washout of the scum with the supernatant. To ensure an optimal hydraulic flow, the outlet channel can be extended along the width of the wall (Heinss *et al.*, 1998). It must be at the opposite side of the inlet zone. Outlets that are positioned near to the shallower side of the tank reduce the carry-over of the settled solids from the thickening layer.

### Operation and Maintenance of Settling-thickening Tanks

At least two settling-thickening tanks should be operated alternately in parallel, in order to allow for sludge removal as tanks should not be loaded during this time. The loading of FS, and the compaction and removal of the thickened sludge and scum comprise the main phases of an operating cycle. These periods allow for the expected solids-liquid separation and thickening operations. While the tanks are not loaded, additional compaction occurs prior to the removal of thickened sludge and scum, due to the lack of hydraulic disturbance (Heinss *et al.*, 1998). During this time further solids-liquid separation occurs, and the SS concentration increases in the thickened sludge and scum.

### Sludge and scum removal

The timing of the removal of sludge and scum as planned for in the design is essential to ensure that the settling-thickening tanks are functioning properly, and that there is adequate depth for the settling of particles, leading to a reduced solids-liquid separation.

If it is observed that a higher volume of thickened sludge has accumulated than what was designed for, this means that the solid load is higher than expected, and operations should be appropriately altered. Sludge removal typically lasts a few hours to a day following the compaction period. Once in operation, detailed monitoring can be done to optimise compaction and sludge removal times based on actual operating conditions.

The first step in sludge and scum removal is typically removal of the scum layer. The scum layer generally has a high solids concentration that cannot be easily pumped and can remain after the thickened sludge is removed, in which case it needs to be manually removed. If possible, scum can be removed with shovels from both sides of the tank when the tank is narrow enough for access, or by mechanical means such as vacuum trucks with strong pumps. Scum can also be removed manually or sucked by a vacuum tanker after emptying the tank. (as followed in the Camberene treatment plant, Senegal, Africa).



Secondly, the supernatant layer is frequently removed by pumping or by gravity (depending on the design). It can be pumped to the parallel settling-thickening tank or to the next step in the treatment chain. The thickened sludge can then be pumped or shovelled out of the tank after the supernatant has been removed. When a pump is used for extracting the thickened sludge, the supernatant layer does not need to be removed, as the supernatant layer can facilitate the pumping of thickened sludge as a pressure is maintained. As tanks are frequently over 2 m deep, adequate access for sludge removal (and for tank and pump cleaning) needs to be integrated into the design. The operator knows when it is time for sludge removal based on the loadings and times given in the design, and also by visual observation.

It is possible to design settling-thickening tanks with devices that continuously scrape and pump the thickened sludge out of the tanks, and remove the scum over the supernatant zone. These devices allow easier operation and increase the management flexibility, but increased operating and maintenance costs need to be taken into consideration. Also their use in DEWATS may not be viable considering energy requirement and operating cost of the plant.

#### Start-up period and seasonal variations:

As settling-thickening tanks rely mainly on physical processes, there is no special requirement for start-up periods. It is however useful to adjust the load time, assess the depths of the different zones and optimise the compaction time and sludge removal frequency. Seasonal variations of meteorological conditions and FS characteristics may influence the efficiency of the tanks. For example, loss of water through evaporation could increase the solids content of the scum. High temperatures may also increase the anaerobic digestion process, and therefore the height of the scum layer.

#### Performance of Settling-Thickening Tanks:

The most important consideration in the performance of settling-thickening tanks is the separation of the liquid and solid fractions. The efficiency of the key mechanisms to achieve this are discussed here.

#### Solids-liquid separation:

In the field, the mean settling efficiency of operating tanks and ponds is about 50-60% of SS in the settled volume. This efficiency can reach up to 80% where the tanks have been adequately designed and operated (Heinss *et al.*, 1999).

The concentration of the thickened sludge (Ct) achieved depends on the operating cycle duration and the initial FS characteristics (thickening ability), as presented in Table 1. Achieving 60 g SS/L in the thickened zone for a seven days' load period seems a reasonable estimate. In Accra, with an operating cycle of about eight weeks, (Heinss *et al.*, 1998) observed a total solid content of 150 g TS/L in the thickened layer.

The scum layer thickness and SS content depends mainly on the operating cycle duration, the FS characteristics and the evaporation process. (Heinss *et al.*, 1998) report a scum layer of 80 cm in settling-thickening tanks operated with cycles of 8 weeks. In the Dakar FSTP the observed scum layer had a depth of 10 to 20 cm after one week of loading.

### Treatment performance

The main objective of settling-thickening tanks is solids-liquid separation, not stabilisation or pathogen reduction. Further treatment steps are required for both the thickened solids and supernatant. Dissolved organic matter, nutrients, and suspended particles will remain in the supernatant. Examples include 50% of influent COD in the settled sludge, and 50% in the supernatant (Badji *et al.*, 2011), and 10% influent BOD and 25% COD in the supernatant (Heinss, *et al.*, 1998). Total pathogen removal or inactivation is also negligible. Many larger pathogens such as Helminth eggs settle out, and the amounts that are partitioned in the solids will be correlated to SS removal efficiency. (Heinss *et al.*, 1998) observed that 50% of the total Helminth eggs were partitioned in the thickened sludge.

|  |   |
|--|---|
| Initial raw FS concentration:                        | $C_{(TS)} = 7 \text{ g TS/L}$<br>$C_{(SS)} = 5 \text{ g SS/L}$                      |
| FS origin:   | Mainly septic tanks (stabilised FS)   |
| Total volatile solids percentage                     | < 70%   |
| Influent flow:                                       | $Q = 140 \text{ m}^3/\text{day}$  |
| FSTP opening time:                                   | 7 h/day<br>5 days/week<br>52 weeks/year   |
| Daily peak flow coefficient:                         | $C_p = 1.6$<br>(peak flow is often in the morning, after the first trucks rotation) |
| Concentration of thickened sludge (1 L Imhoff cones) | 60 g SS/L   |
| Settling ability (1 L Imhoff cones)                  | Good (SVI = 23 << 100)  |

Table 2 Results of preliminary studies to determine design parameters (Source: Pierre-Henri Dodane *et al.*;

### Advantages and Constraints of Settling-Thickening Tanks

Settling-thickening tanks are efficient as a first treatment step as they rapidly achieve solids-liquid separation, they are relatively robust and resilient, and they reduce the volume of sludge for subsequent treatment steps.

### Constraints of settling-thickening tanks include

- lack of experience operating with FS, and lack of empirical data and results on which to base designs on;
- settled sludge still has relatively high water content and requires further dewatering;

- the liquid fraction remains highly concentrated in SS and organics; and
- pathogen removal is not significant, and the end products of settling tanks therefore, cannot be discharged into water bodies or directly used in agriculture.

### **FACILITY DESIGN OF SETTLER CUM THICKENER:**

#### **Design considerations:**

1. Faecal sludge origin: septic tank (stabilised FS)
2. The terminal settling velocity in the tank is taken as  $V_c = 0.5$  m/hour based on SVI and experience.
3. The expected settling efficiency is taken as 80% of SS.
4. Two parallel tanks are designed to allow alternate cleaning and loading.
5. The loading of one week is considered to minimise anaerobic digestion and gas up-flow. This entails one tank is to be loaded one week out of every two weeks while the other one is being emptied in the same period of time. Hence the cycle of operation is two weeks.
6. A short compaction period of 2-3 days is considered before removal of thickened sludge which means that the thickened sludge is scheduled to be removed after every 10 days where the sludge is still sufficiently liquid for extraction through a sludge / slurry pump.
7. The daily peak co-efficient is considered as 1.6
8. The SeTP opening time is 8 hours a day and 5 days a week (N).
9. The operator has gained experience in wastewater treatment and therefore, the sludge pumping and tank cleaning is carried out correctly.
10. The initial SS concentration in the septage is taken as 5 g/litre
11. Sludge settling characteristic is good i.e. SVI <100
12. Concentration of thickened sludge, ' $C_t$ ' is taken as 60 g SS / litre

#### **Design calculation for dimensioning:**

Peak flow,  $Q_p = Q \cdot C_p / 8 = 20 \times 1.6 / 8 = 4$  m<sup>3</sup>/hour.

Surface area required,  $S = Q_p / V_c = 4 / 0.5 = 8$  m<sup>2</sup>, two tanks of 10 m<sup>2</sup> each is to be constructed.

Sludge quantity as SS,  $M = Q \times C_i = 20 \times 5 = 100$  SS kg/day

Considering a settling efficiency of 80% as above,

Mass of thickened sludge,  $M_t = 0.8 \times 100 = 80$  SS kg/day

Volume of thickened sludge,  $V_t = M_t \times N / C_t = 80 \times 5 / 60 = 6.67$  m<sup>3</sup> / 10 days

#### **Tank dimension:**

Width to length ratio may be adopted as 0.2,  $5w^2 = 10$ ,  $w = 1.414$  m, Provide 2.0 m,  $l = 5$  m + 2 m for baffles

Zone depth: Scum = 0.4 m, Supernatant = 0.5 m, transition = 0.5 m

Thickening zone =  $6.67/10 = 0.67$  m

Total SWD =  $0.4 + 0.5 + 0.5 + 0.67 = 2.07$  m Say, 2.10 m

Tank dimension, L= 7 m, B= 2 m, SWD = 2.10 m

Slope towards inlet = 2%, pump pit, 1m x 1m

Outlet baffle opening = 0.7 m below liquid surface and 1m above bottom at outlet.

One sludge pump shall be provided with 100% standby.

Sludge shall be discharged every 10 days from the tank. The volume to be discharged is  $7 \text{ m}^3$

A pump suitable to discharge  $7 \text{ m}^3$  of sludge on to a drying bed shall be required.

Treatment of liquid stream:

The treatment of liquid stream after sludge separation at the settler shall be carried out through DEWATS. The selected DEWATS components for the purpose of treatment are;

1. Anaerobic baffled reactor with provision of anaerobic filters,
2. Horizontal filter,

End use of effluent as well as the dried sludge shall depend on the demand. During the period when the demand has a possibility to grow, disposal through burial etc. can be explored. A detailed location survey as well as market survey will have to be conducted for the purpose. The possibility of co-composting with vegetable waste collected from the vegetable / fruits market should also be examined.

ANAEROBIC BAFFLED REACTOR DESIGN:

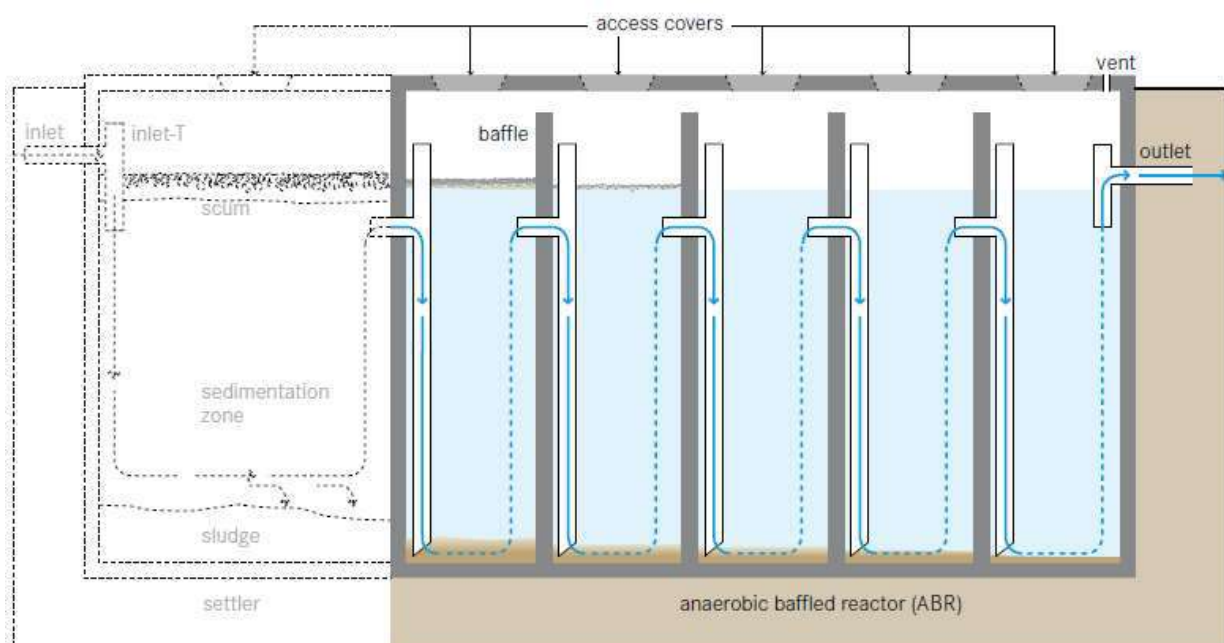

Figure 6: Anaerobic baffled Reactor (Source: Tilley *et al*, 2014).

The up-flow chambers provide enhanced removal and digestion of organic matter. BOD may be reduced by up to 90%, which is far superior to its removal in a conventional Septic Tank.

**Design Considerations:** The majority of settleable solids are removed in a sedimentation chamber in front of the actual ABR. Small-scale, stand-alone units typically have an integrated settling compartment, but primary sedimentation can also take place in a separate Settler or another preceding technology (e.g., existing Septic Tanks). Designs without a settling compartment are of particular interest for Septage Treatment plants that combine the ABR with another technology for primary settling, or where prefabricated, modular units are used. Typical inflows range from 2 to 200 m<sup>3</sup> per day. Critical design parameters include a hydraulic retention time (HRT) between 48 to 72 hours, up-flow velocity of the wastewater below 0.6 m/h and the number of up-flow chambers (3 to 6). The connection between the chambers can be designed either with vertical pipes or baffles. Accessibility to all chambers (through access ports) is necessary for maintenance. Usually, the biogas produced in an ABR through anaerobic digestion is not collected because of its insufficient amount. The tank should be vented to allow for controlled release of odorous and potentially harmful gases.

**Appropriateness:** This technology is easily adaptable and can be applied at the household level, in small neighbourhoods or even in bigger catchment areas. It is most appropriate where a relatively constant amount of black-water and greywater is generated. This technology is suitable for areas where land may be limited since the tank is most commonly installed underground and requires a small area. ABRs can be installed in every type of climate, although the efficiency is lower in colder climates. They are not efficient at removing nutrients and pathogens. The effluent usually requires further treatment.

**Health Aspects/Acceptance:** Under normal operating conditions, users do not come in contact with the influent or effluent. Effluent, scum and sludge must be handled with care as they contain high levels of pathogenic organisms. The effluent contains odorous compounds that may have to be removed in a further polishing step. Care should be taken to design and locate the facility such that odours do not bother community members.

**Operation & Maintenance:** An ABR requires a start-up period of several months to reach full treatment capacity since the slow growing anaerobic biomass first needs to be established in the reactor. To reduce start-up time, the ABR can be inoculated with anaerobic bacteria, e.g., by adding fresh cow dung or Septic Tank sludge. The added stock of active bacteria can then multiply and adapt to the incoming wastewater. Because of the delicate ecology, care should be taken not to discharge harsh chemicals into the ABR. Scum and sludge levels need to be monitored to ensure that the tank is functioning well. Process operation in general is not required, and maintenance is limited to the removal of accumulated sludge and scum every 1 to 3 years. This is best done using a Motorized

Emptying technology. The desludging frequency depends on the chosen pre-treatment steps, as well as on the design of the ABR. ABR tanks should be checked from time to time to ensure that they are watertight. ABRs when employed in treating the sludge supernatant may not require inoculation for start-up since the facility preceding the treatment in SeTP can provide the required inoculation.

**Plus & Minus:**

- + Resistant to organic and hydraulic shock loads
  - + No electrical energy is required
  - + Low operating costs
  - + Long service life
  - + High reduction of BOD
  - + Low sludge production; the sludge is stabilized
  - + Moderate area requirement (can be built underground)
- 
- Requires expert design and construction
  - Low reduction of pathogens and nutrients
  - Effluent and sludge require further treatment and/or appropriate discharge

**FACILITY DESIGN ANAEROBIC BAFFLED REACTOR:**

**Design Considerations:**

1. The up-flow velocity shall remain below 2 m/hour.
2. The organic loading shall be below 3 Kg COD / m<sup>3</sup>. day
3. The HRT of the liquid fraction i.e. above sludge volume shall not be less than 8 hours.
4. Sludge storage volume should be provided @ 4 l/m<sup>3</sup> BOD<sub>inflow</sub> in the settler and 1.4 l/m<sup>3</sup> BOD<sub>removed</sub> in the upstream treatment facility i.e. settler cum thickener etc.
5. Minimum number of chambers should be four excluding the settler

**Discharge from settler:**

After the process of settling, the supernatant shall pass through an ABR. The volume of supernatant works out to around 90% of the influent volume.

The daily flow to the ABR = 0.9 x 20 = 18 m<sup>3</sup>/day

It is considered to have two tanks in parallel having a capacity to handle 2/3<sup>rd</sup> of the above flow in each of the installation. Hence flow to be considered to each installation = 0.67 x 18 = 12.06 Say, 12 m<sup>3</sup>/day. The SS concentration from settler supernatant is considered to be 2.2 g / litre or 2.2 Kg SS / m<sup>3</sup>. Expected COD removal efficiency shall be around 80%. The organic loading shall be taken as 3 Kg COD / m<sup>3</sup>.day since the supernatant from the settler is expected to have COD in the range of 20-40% of the septage inflow. The calculation of the dimension of the system has been shown in the spreadsheet in fig 16. A BOD<sub>5</sub> loading of 800 ppm has been considered as dissolved however, the total COD loading threshold has been taken as 3.0 Kg / m<sup>3</sup>.day. The curves taken for calculation of dimension of ABR and Horizontal Filter (Constructed Wetland) is reproduced below. Values in figures 7-12 recommended by Sasse, 1998, have been used in determining the capacity of the system. The spreadsheet proposed by Sasse, 1998, has been used to determine the dimensions of the ABR as shown in figure 13.

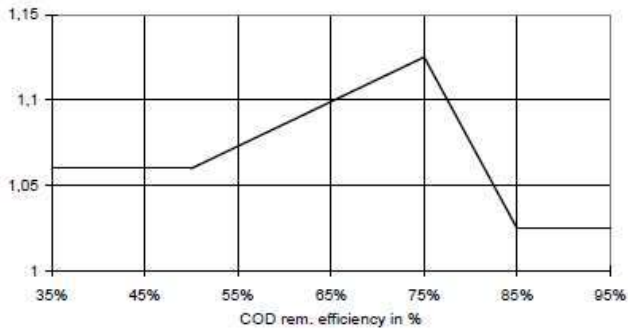

**Fig 7: Simplified curve of ratio of efficiency of BOD removal to COD removal**

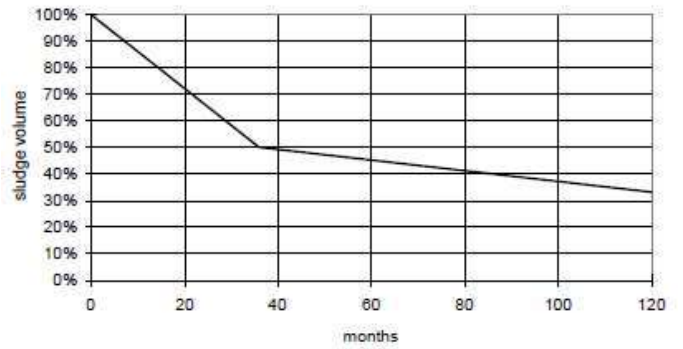

**Fig 8: Reduction of sludge volume during storage**

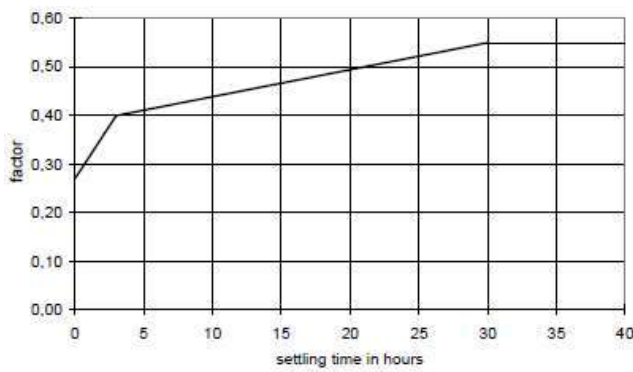

**Fig 9: COD removal in settlers**

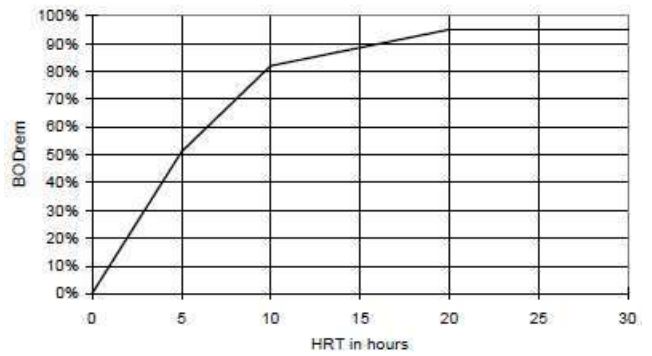

**Fig 10: Baffled septic tank, BOD<sub>rem</sub> in relation to HRT**

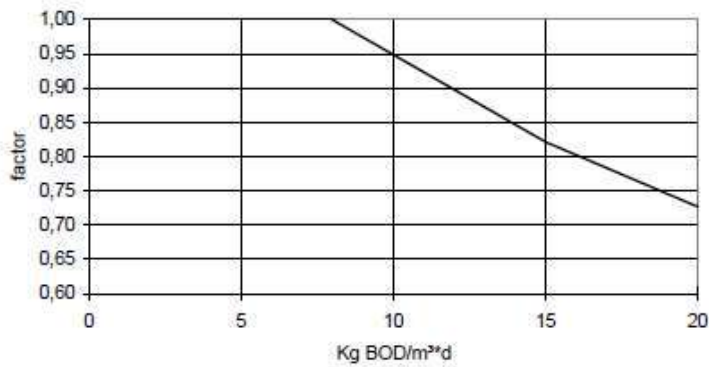

**Fig 11: Baffled septic tank, BOD<sub>rem</sub> in relation to organic load**

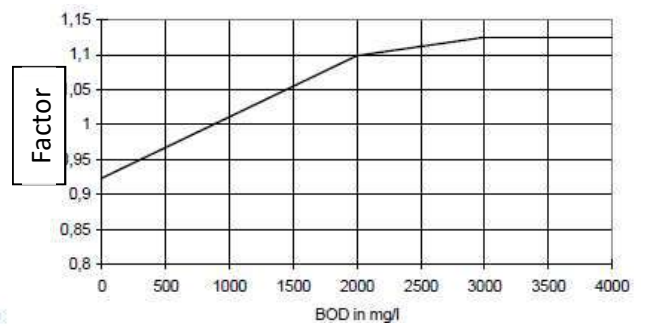

**Fig 12: Baffled septic tank, BOD<sub>rem</sub> in relation to wastewater strength**



| GENERAL SPREADSHEET FOR BAFFLED REACTOR WITH INTEGRATED SETTLER |                                     |                                |   |  |                          |                          |                                  |   |                              |  |
|---|-------------------------------------|--------------------------------|---|--|--------------------------|--------------------------|----------------------------------|---|------------------------------|--|
| Daily Wastewater Flow   | time of most wastewater flow        | max peak flow per hour         | COD inflow                                    | BOD5 Inflow  | COD/BOD ratio            | Settleable COD/BOD ratio | lowest digester temp             | de-sludging interval                          | HRT in settler               | COD removal rate in settler                  |
| avg   | data                                | max.                           | data  | data   | Cal                      | data                     | data                             | data  | data                         | result                                       |
| m <sup>3</sup> /day   | hour                                | m <sup>3</sup> /hour           | mg/l  | mg/l   | ratio                    | mg/l                     | °C                               | months  | hour                         | %  |
| 12  | 8                                   | 2                              | 2200  | 800  | 3                        | 0.42                     | 25                               | 18  | 1.5                          | 23%  |
|   |                                     |                                |   |  |                          |                          |                                  |   |                              |  |
| TREATMENT DATA  |                                     |                                |   |  |                          |                          |                                  |   |                              |  |
| BOD removal rate in settler                                     | Inflow into baffled reactor         |                                | COD/BOD <sub>5</sub> ratio after settler      | factors to calculate COD removal rate of baffled reactor |                          |                          | COD Remv, 25°, COD 1500          | Theoretical removal rate according to factors | COD removal rate baffle only | COD outflow                                  |
| Cal   | COD                                 | BOD <sub>5</sub>               | Cal   | calculated according to graphs by Sasse, 1998            |                          |                          | Cal                              | Cal   | Cal                          | Cal  |
| %   | mg/l                                | mg/l                           | number  | f-overload   | f-Strength               | f-temp                   | f-HRT                            | %   | %                            | mg/l   |
| 24%   | 1699.5                              | 607.08                         | 2.80  | 1  | 0.971                    | 1                        | 1.02                             | 99%   | 92%                          | 134.47                                       |
| 1.06  | < COD/BOD Removal Factor            |                                |   |  |                          |                          | COD/BOD Removal Factor>          |   |                              | 1.04   |
| Dimensions of Settler   |                                     |                                |   |  |                          |                          | Baffled septic tank              |   |                              |  |
| Total COD removal rate  | Total BOD <sub>5</sub> removal rate | BOD <sub>5</sub> outflow       | Inner measurements chosen according to volume |  | Sludge accumulation rate | Volume of settler        | length of settler                | Max up-flow vel                               | No of up-flow chambers       | Depth at outlet                              |
| cal   | cal                                 | cal                            | width   | depth  | cal                      | cal                      | data                             | data  | data                         | data   |
| %   | %                                   | mg/l                           | m   | m  | l/g COD                  | m <sup>3</sup>           | m                                | m/h   | no.                          | m  |
| 83%   | 87%                                 | 105.79                         | 4   | 1.75   | 0.004                    | 0.99                     | 4                                | 1   | 5                            | 1.75   |
|   |                                     |                                |   |  |                          |                          |                                  |   |                              |  |
| Dimensions of baffled septic tank                               |                                     |                                |   |  |                          |                          | Status                           |   |                              |  |
| Length of chambers <= half depth                                |                                     | Area of single up flow chamber | Width of Chambers                             |  | Actual up flow velocity  | Width of downflow shaft  | Actual volume of baffled reactor | Actual Total HRT                              | Org Load BOD <sub>5</sub>    | Biogas (70% CH <sub>4</sub> , 50% dissolved) |
| cal   | data                                | cal                            | cal   | data   | cal                      | data                     | cal                              | cal   | cal                          | cal  |
| m   | m                                   | m <sup>2</sup>                 | m   | m  | m/h                      | m                        | m <sup>3</sup>                   | h   | kg/m <sup>3</sup> .day       | m <sup>3</sup> /day                          |
| 0.875   | 0.875                               | 1.5                            | 1.71  | 2.00   | 0.86                     | 0.30                     | 20.56                            | 39.17   | 1.063                        | 6.20   |

Fig 13: Showing the Design dimensions of Anaerobic Baffled Reactor (Source: Sasse, 1998)



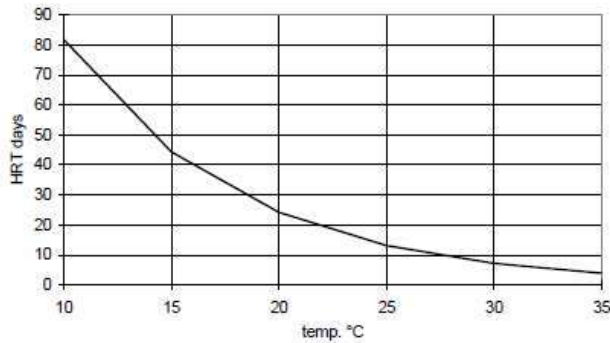

**Fig 14: Planted gravel filter, 90% BOD rem.**

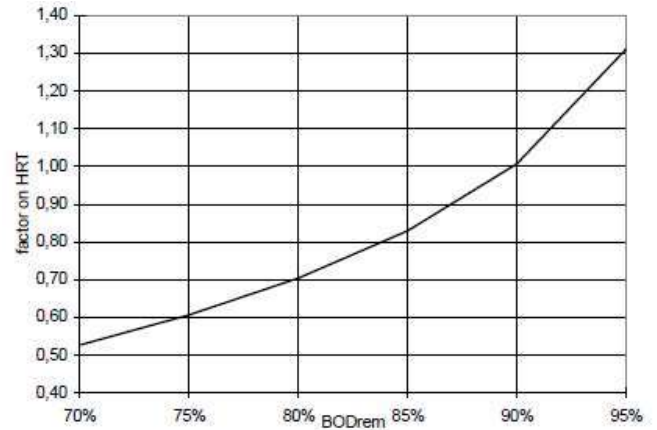

**Fig 15: Planted gravel filter, 35% pore space; 25°C**

### DESIGN AND OPERATIONAL PRINCIPLES OF CONSTRUCTED WETLANDS

Sasse, 1998, describes regarding three basic treatment systems which may fall in the category of constructed wetlands. These are;

- the overland treatment system
- the vertical flow filter, and
- the horizontal flow filter.

For overland treatment the water is distributed on carefully contoured land by sprinklers. The system requires permanent attendance and maintenance. For that reason, it does not belong to DEWATS.

For vertical filter treatment the wastewater is distributed with the help of a dosing device on two or three filter beds which are charged alternately. Charging intervals must be strictly followed which makes the vertical filter less suitable for DEWATS.

The horizontal filter is simple by principle and requires almost no maintenance, however under the condition that it has been well designed and constructed. Design and construction requires a solid understanding of the treatment process and good knowledge of the filter medium that is to be used.

Constructed wetlands, especially sand and gravel filters, are by no means a simple technology, although they may look like part of nature. Before deciding on filter treatment, one should always consider the alternative of constructing wastewater ponds instead. Nonetheless, filter treatment has the great advantage of keeping the wastewater below ground. The horizontal and the vertical filter are two systems that are principally different. The horizontal filter is permanently soaked with water and operates partly aerobic (free oxygen present), partly anoxic (no free oxygen but nitrate -NO<sub>3</sub>- present) and partly anaerobic (no free oxygen and no nitrate present). The vertical filter is charged in intervals (similar to a trickling filter) and functions predominantly aerobically. Although the vertical filter requires only about half the area of a horizontal filter and has better treatment qualities, only the horizontal filter is considered a DEWATS technology for the reason that it has no movable parts and does not require permanent operational control. Types of constructed wetlands based on above categorisation are illustrated below;

A free-water surface constructed wetland which comes under overland treatment system aims to replicate the naturally occurring processes of a natural wetland, marsh or swamp. As water slowly flows through the wetland, particles settle, pathogens are destroyed, and organisms and plants utilize the nutrients. This type of constructed wetland is commonly used as an advanced treatment after secondary or tertiary treatment processes.

### FREE-WATER SURFACE CONSTRUCTED WETLAND

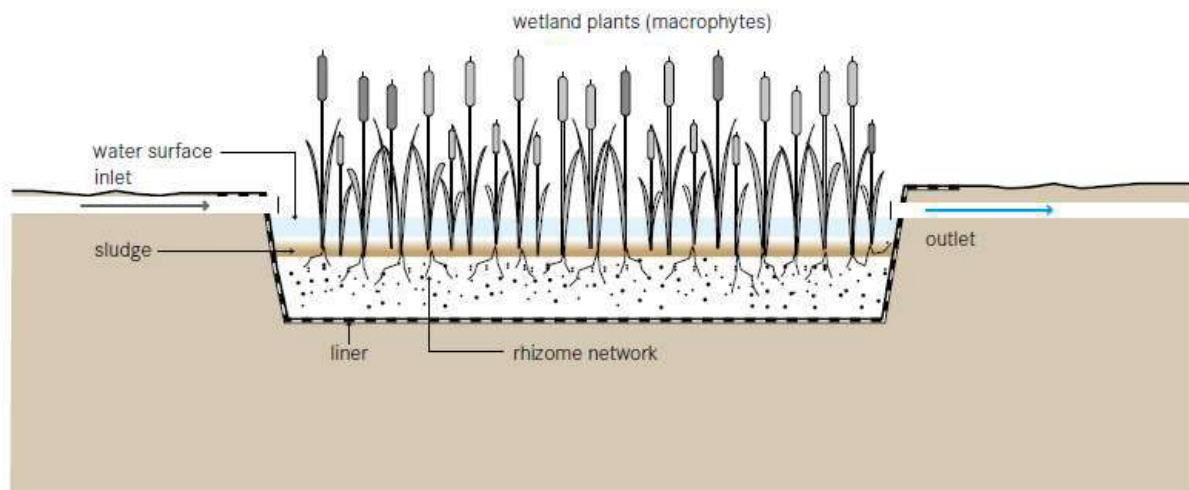

Figure 16: Free-water surface Constructed Wetland (Source: Tilley *et al*, 2014).

Unlike the Horizontal Subsurface Flow Constructed Wetland, the free-water surface constructed wetland allows water to flow above ground exposed to the atmosphere and to direct sunlight. As the water slowly flows through the wetland, simultaneous physical, chemical and biological processes filter solids, degrade organics and remove nutrients from the wastewater.

Raw black-water should be pre-treated to prevent the excess accumulation of solids and garbage. Once in the pond, the heavier sediment particles settle out, and this also removes the nutrients attached to them. Plants, and the communities of microorganisms that they support (on the stems and roots), take up nutrients like nitrogen and phosphorus. Chemical reactions may cause other elements to precipitate out of the wastewater. Pathogens are removed from the water by natural decay, predation from higher organisms, sedimentation and UV irradiation.

Although the soil layer below the water is anaerobic, the plant roots exude (release) oxygen into the area immediately surrounding the root hairs, thus, creating an environment for complex biological and chemical activity.

**Design Considerations:** The channel or basin is lined with an impermeable barrier (clay or geotextile) covered with rocks, gravel and soil and planted with native vegetation (e.g., cattails, reeds and/or rushes). The wetland is flooded with wastewater to a depth of 10 to 45 cm above ground level. The wetland is compartmentalized into at least two independent flow paths. The number of compartments in series depends on the treatment target. The efficiency of the free-water surface

constructed wetland also depends on how well the water is distributed at the inlet. Wastewater can be fed into the wetland, using weirs or by drilling holes in a distribution pipe, to allow it to enter at evenly spaced intervals.

**Appropriateness:** Free-water surface constructed wetlands can achieve a high removal of suspended solids and moderate removal of pathogens, nutrients and other pollutants, such as heavy metals. This technology is able to tolerate variable water levels and nutrient loads. Plants limit the dissolved oxygen in the water from their shade and their buffering of the wind; therefore, this type of wetland is only appropriate for low-strength wastewater. This also makes it appropriate only when it follows some type of primary treatment to lower the BOD. Because of the potential for human exposure to pathogens, this technology is rarely used as secondary treatment. Typically, it is used for polishing effluent that has been through secondary treatment, or for storm water retention and treatment.

The free-water surface wetland is a good option where land is cheap and available. Depending on the volume of the water and the corresponding area requirement of the wetland, it can be appropriate for small sections of urban areas, as well as for peri-urban and rural communities. This technology is best suited for warm climates, but can be designed to tolerate some freezing and periods of low biological activity.

**Health Aspects/Acceptance:** The open surface can act as a potential breeding ground for mosquitoes. However, good design and maintenance can prevent this. Free-water surface constructed wetlands are generally aesthetically pleasing, especially when they are integrated into pre-existing natural areas. Care should be taken to prevent people from coming in contact with the effluent because of the potential for disease transmission and the risk of drowning in deep water.

**Operation & Maintenance:** Regular maintenance should ensure that water is not short-circuiting, or backing up because of fallen branches, garbage, or beaver dams blocking the wetland outlet. Vegetation may have to be periodically cut back or thinned out.

#### **Plus & Minus**

- + Aesthetically pleasing and provides animal habitat
- + High reduction of BOD and solids; moderate pathogen removal
- + Can be built and repaired with locally available materials
- + No electrical energy is required
- + No real problems with odours if designed and maintained correctly
- + Low operating costs
  
- May facilitate mosquito breeding
- Requires a large land area
- Long start-up time to work at full capacity
- Requires expert design and construction

## VERTICAL FLOW CONSTRUCTED WETLAND

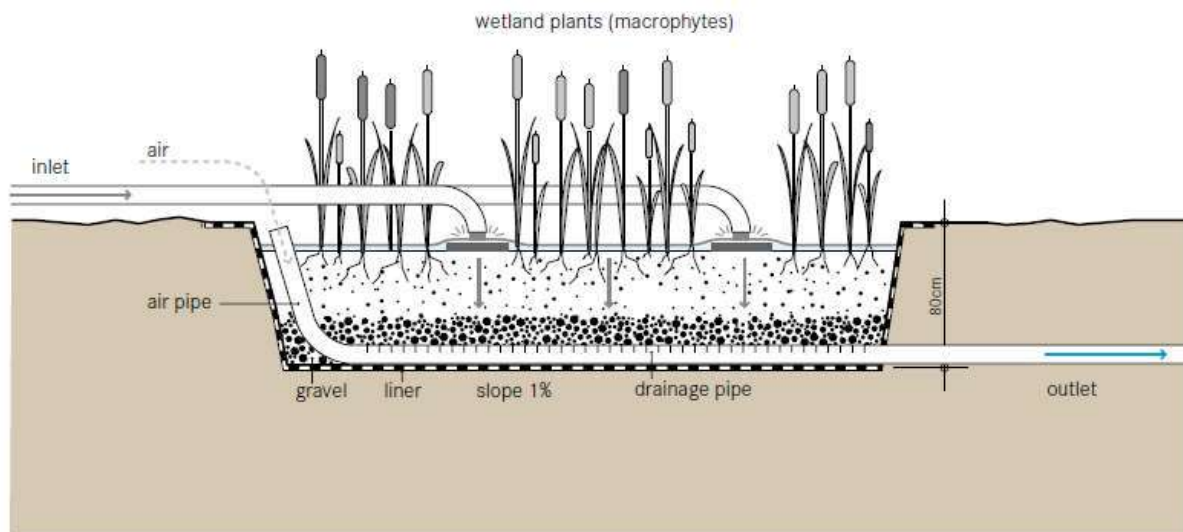

Figure 17: Vertical Flow Constructed Wetland (Source: Tilley *et al*, 2014).

A vertical flow constructed wetland is a planted filter bed that is drained at the bottom. Wastewater is poured or dosed onto the surface from above using a mechanical dosing system. The water flows vertically down through the filter matrix to the bottom of the basin where it is collected in a drainage pipe. The important difference between a vertical and horizontal wetland is not simply the direction of the flow path, but rather the aerobic conditions.

By intermittently dosing the wetland (4 to 10 times a day), the filter goes through stages of being saturated and unsaturated, and, accordingly, different phases of aerobic and anaerobic conditions. During a flush phase, the wastewater percolates down through the unsaturated bed. As the bed drains, air is drawn into it and the oxygen has time to diffuse through the porous media. The filter media acts as a filter for removing solids, a fixed surface upon which bacteria can attach and a base for the vegetation. The top layer is planted and the vegetation is allowed to develop deep, wide roots, which permeate the filter media. The vegetation transfers a small amount of oxygen to the root zone so that aerobic bacteria can colonize the area and degrade organics. However, the primary role of vegetation is to maintain permeability in the filter and provide habitat for microorganisms. Nutrients and organic material are absorbed and degraded by the dense microbial populations. By forcing the organisms into a starvation phase between dosing phases, excessive biomass growth can be decreased and porosity increased.

**Design Considerations:** The vertical flow constructed wetland can be designed as a shallow excavation or as an above ground construction. Clogging is a common problem. Therefore, the influent should be well settled in a primary treatment stage before flowing into the wetland. The design and size of the wetland is dependent on hydraulic and organic loads. Generally, a surface area of about 1 to 3 m<sup>2</sup> per person equivalent is required. Each filter should have an impermeable liner and an effluent collection system. A ventilation pipe connected to the drainage system can contribute to

aerobic conditions in the filter. Structurally, there is a layer of gravel for drainage (a minimum of 20 cm), followed by layers of sand and gravel. Depending on the climate, *Phragmites australis* (reed), *Typha* sp. (cattails) or *Echinochloa pyramidalis* are common plant options. Testing may be required to determine the suitability of locally available plants with the specific wastewater.

Due to good oxygen transfer, vertical flow wetlands have the ability to nitrify, but denitrification is limited. In order to create a nitrification-denitrification treatment train, this technology can be combined with a Free-water Surface or Horizontal Flow Wetland.

**Appropriateness:** The vertical flow constructed wetland is a good treatment for communities that have primary treatment (e.g., Septic Tanks), but are looking to achieve a higher quality effluent. Because of the mechanical dosing system, this technology is most appropriate where trained maintenance staff, constant power supply, and spare parts are available. Since vertical flow constructed wetlands are able to nitrify, they can be an appropriate technology in the treatment process for wastewater with high ammonium concentrations.

Vertical flow constructed wetlands are best suited to warm climates, but can be designed to tolerate some freezing and periods of low biological activity.

**Health Aspects/Acceptance:** Pathogen removal is accomplished by natural decay, predation by higher organisms, and filtration. The risk of mosquito breeding is low since there is no standing water. The system is generally aesthetic and can be integrated into wild areas or parklands. Care should be taken to ensure that people do not come in contact with the influent because of the risk of infection.

**Operation & Maintenance:** During the first growing season, it is important to remove weeds that can compete with the planted wetland vegetation. Distribution pipes should be cleaned once a year to remove sludge and biofilm that might block the holes. With time, the gravel will become clogged by accumulated solids and bacterial film. Resting intervals may restore the hydraulic conductivity of the bed. If this does not help, the accumulated material has to be removed and clogged parts of the filter material replaced. Maintenance activities should focus on ensuring that primary treatment is effective at reducing the concentration of solids in the wastewater before it enters the wetland. Maintenance should also ensure that trees do not grow in the area as the roots can harm the liner.

**Plus & Minus:**

- + High reduction of BOD, suspended solids and pathogens
- + Ability to nitrify due to good oxygen transfer
- + Does not have the mosquito problems of the Free-Water Surface Constructed Wetland
- + Less clogging than in a Horizontal Subsurface Flow Constructed Wetland
- + Requires less space than a Free-Water Surface or Horizontal Flow Wetland
- + Low operating costs
  
- Requires expert design and construction, particularly, the dosing system
- Requires more frequent maintenance than a Horizontal Subsurface Flow Constructed Wetland
- A constant source of electrical energy may be required
- Long start-up time to work at full capacity
- Not all parts and materials may be locally available

## HORIZONTAL SUB-SURFACE FLOW CONSTRUCTED WETLAND

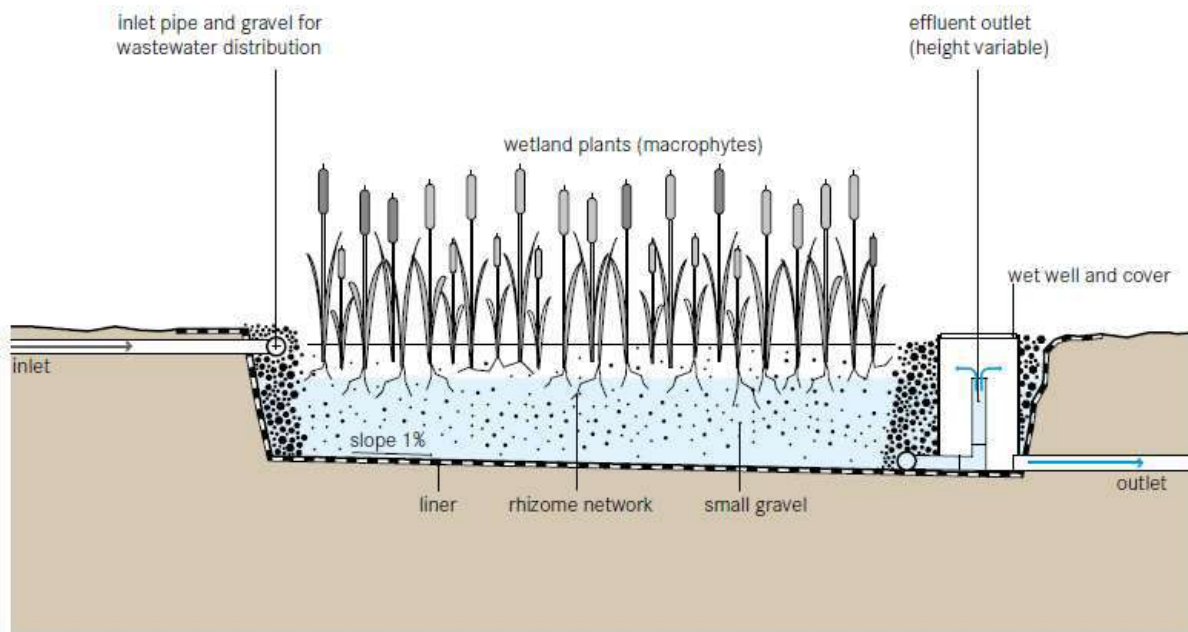

Figure 18: Horizontal Subsurface Flow Constructed Wetland (Source: Tilley *et al*, 2014).

A horizontal subsurface flow constructed wetland is a large gravel and sand-filled basin that is planted with wetland vegetation. As wastewater flows horizontally through the basin, the filter material filters out particles and microorganisms degrade the organics.

The filter media acts as a filter for removing solids, a fixed surface upon which bacteria can attach, and a base for the vegetation. Although facultative and anaerobic bacteria degrade most organics, the vegetation transfers a small amount of oxygen to the root zone so that aerobic bacteria can colonize the area and degrade organics as well. The plant roots play an important role in maintaining the permeability of the filter.

**Design Considerations:** The design of a horizontal subsurface flow constructed wetland depends on the treatment target and the amount and quality of the influent. It includes decisions about the amount of parallel flow paths and compartmentation. The removal efficiency of the wetland is a function of the surface area (length multiplied by width), while the cross-sectional area (width multiplied by depth) determines the maximum possible flow. Generally, a surface area of about 5 to 10 m<sup>2</sup> per person equivalent is required. Pre- and primary treatment is essential to prevent clogging and ensure efficient treatment. The influent can be aerated by an inlet cascade to support oxygen-dependent processes, such as BOD reduction and nitrification.

The bed should be lined with an impermeable liner (clay or geotextile) to prevent leaching. It should be wide and shallow so that the flow path of the water in contact with vegetation roots is maximized. A wide inlet zone should be used to evenly distribute the flow. A well-designed inlet that allows for even distribution is important to prevent short-circuiting. The outlet should be variable so that the

water surface can be adjusted to optimize treatment performance. Small, round, evenly sized gravel (3 to 32 mm in diameter) is most commonly used to fill the bed to a depth of 0.5 to 1 m. To limit clogging, the gravel should be clean and free of fines. Sand is also acceptable, but is more prone to clogging than gravel. In recent years, alternative filter materials, such as *Polyethylene terephthalate* (PET), have been successfully used. The water level in the wetland is maintained at 5 to 15 cm below the surface to ensure subsurface flow. Any native plant with deep, wide roots that can grow in the wet, nutrient-rich environment is appropriate. *Phragmites australis* (reed) is a common choice because it forms horizontal rhizomes that penetrate the entire filter depth.

**Appropriateness** Clogging is a common problem and, therefore, the influent should be well settled with primary treatment before flowing into the wetland. This technology is not appropriate for untreated domestic wastewater (i.e. black-water). It is a good treatment for communities that have primary treatment (e.g., Septic Tanks), but are looking to achieve a higher quality effluent. The horizontal subsurface flow constructed wetland is a good option where land is cheap and available. Depending on the volume of the water and the corresponding area requirement of the wetland, it can be appropriate for small sections of urban areas, as well as for peri-urban and rural communities. It can also be designed for single households.

This technology is best suited for warm climates, but it can be designed to tolerate some freezing and periods of low biological activity. If the effluent is to be reused, the losses due to high evapotranspiration rates could be a drawback of this technology, depending on the climate.

**Health Aspects/Acceptance:** Significant pathogen removal is accomplished by natural decay, predation by higher organisms, and filtration. As the water flows below the surface, any contact of pathogenic organisms with humans and wildlife is minimized. The risk of mosquito breeding is reduced since there is no standing water compared to the risk associated with Free-Water Surface Constructed Wetlands. The wetland is aesthetically pleasing and can be integrated into wild areas or parklands.

**Operation & Maintenance:** During the first growing season, it is important to remove weeds that can compete with the planted wetland vegetation. With time, the gravel will become clogged with accumulated solids and bacterial film. The filter material at the inlet zone will require replacement every 10 or more years. Maintenance activities should focus on ensuring that primary treatment is effective at reducing the concentration of solids in the wastewater before it enters the wetland. Maintenance should also ensure that trees do not grow in the area as the roots can harm the liner.

**Plus & Minus:**

- + High reduction of BOD, suspended solids and pathogens
- + Does not have the mosquito problems of the Free-Water Surface Constructed Wetland
- + No electrical energy is required
- + Low operating costs
  
- Requires a large land area
- Little nutrient removal
- Risk of clogging, depending on pre- and primary treatment
- Long start-up time to work at full capacity
- Requires expert design and construction

From the above discussion it is evident that selection of wetland option depends on many factors local as well as the volume of flow to handle and the of course the climatic conditions. The discussion above indicates that a horizontal constructed wetland will be much easier to adopt and implement and also the O&M is quite simpler in comparison to other options. However, in order to utilise the nutrient fraction in the effluent it may also entail adoption of a combination of HF and VF. However, under the present context the design of HF has been provided.

#### **FACILITY DESIGN OF WETLAND:**

##### **SPREADSHEET RESULT OF CONSTRUCTED WET LAND (HORIZONTAL FILTER)**

The above tables and formulae from Sasse, 1998 were adopted to derive the dimension of the gravel filter preceded by ABR and Settling-thickening tanks. Considering the available land area, the wetland has not been duplicated. However, a larger wetland can be constructed or a vertical filter can also be installed / added so that the effluent quality is quite acceptable as per the regulatory norms. The gravel filter will be followed by one small sump for collection and storage of effluent with a one-day capacity for storage and further disposal. The effluent depending upon its design quality can be discharged with low dose chlorination, if discharged to the streams or without chlorination for irrigation of parks that are developed under AMRUT Mission in and around Sambalpur town. Since the effluent shall contain nutrients in the form of nitrates and phosphorus, it will be appropriate to use the effluent as water for irrigation through sprinklers or diffusers under the soil. This can also be used to recharge ground water in specific locations away and having a safe distance from surface water sources. The developer / designer shall bring in the technology for such option in using the effluent. Values in figures 14-15 proposed by Sasse, 1998, have been used to size the horizontal filter. The computer spreadsheet developed by Sasse, 1998 for DEWATS has been used to derive the wetland size and loading capacity and compiled in figure 19 below.



| GENERAL SPREADSHEET FOR PLANTED GRAVEL FILTER AND INPUT DATA |              |                          |                      |                          |                               |                        |              |                  |  |                                     |                                   |
|--|--------------|--------------------------|----------------------|--------------------------|-------------------------------|------------------------|--------------|------------------|--|-------------------------------------|-----------------------------------|
| Average Flow   | COD Inflow   | BOD <sub>5</sub> Inflow  | COD/BOD ratio        | BOD <sub>5</sub> Outflow | BOD <sub>5</sub> Removal rate | COD Removal            | COD outflow  | Mean Annual Temp | HRT Factor according to k <sub>20</sub> =0.3 | HRT                                 | Hydraulic Conductance, Ks         |
| data   | data         | data                     | calc                 | wanted                   | calc                          | calc                   | calc         | data             | calc   | calc                                | data                              |
| m <sup>3</sup> /day  | mg/l         | mg/l                     | ratio                | mg/l                     | %                             | %                      | mg/l         | °C               | via graph                                    | days                                | m/day                             |
| 20   | 135          | 106                      | 1.27                 | 9.5                      | 91%                           | 89%                    | 15           | 25               | 1.1  | 13.81                               | 200                               |
|  |              |                          |                      |                          |                               | 1.025                  |              |                  |  |                                     | 0.00231                           |
| DIMENSIONS   |              |                          |                      |                          |                               |                        |              |                  |  | RESULTS                             |                                   |
| HRT in 30% Pore Space  | Bottom Slope | Depth of Filter at Inlet | Cross Section Area   | Width of Filter Basin    | Surface Area required         | Length of Filter Basin | Chosen Width | Length Chosen    | Actual Surfacer Area                         | Hydraulic loading on chosen surface | Organic loading on chosen surface |
| calc   | chosen       | chosen                   | calc                 | calc                     | calc                          | calc                   | chosen       | chosen           | Check!                                       | calc                                | calc                              |
| days   | %            | m                        | m <sup>2</sup>       | m                        | m <sup>2</sup>                | m                      | m            | m                | m <sup>2</sup>                               | m/day                               | g/m <sup>2</sup> BOD              |
| 4.833  | 1%           | 0.6                      | 14.13                | 23.56                    | 460.31                        | 19.54                  | 25           | 20               | 500  | 0.04                                | 4.240                             |
|  |              | 0.3 to 0.6m              | Max BOD <sub>5</sub> | 150                      | g/m <sup>2</sup>              |                        | 23.56        |                  | Max Load>                                    | 0.10                                | 10                                |

Fig 19: Showing the Design dimensions of gravel bed filter

## DESIGN AND OPERATIONAL PRINCIPLES OF UNPLANTED SLUDGE DRYING BEDS:

### Treatment principle

A FS treatment plant (FSTP) or septage treatment plant consists of several drying beds in one location. Sludge is deposited on each of these drying beds where it remains until the desired moisture content is achieved. It is subsequently mechanically or manually removed for disposal or further treatment and reuse.

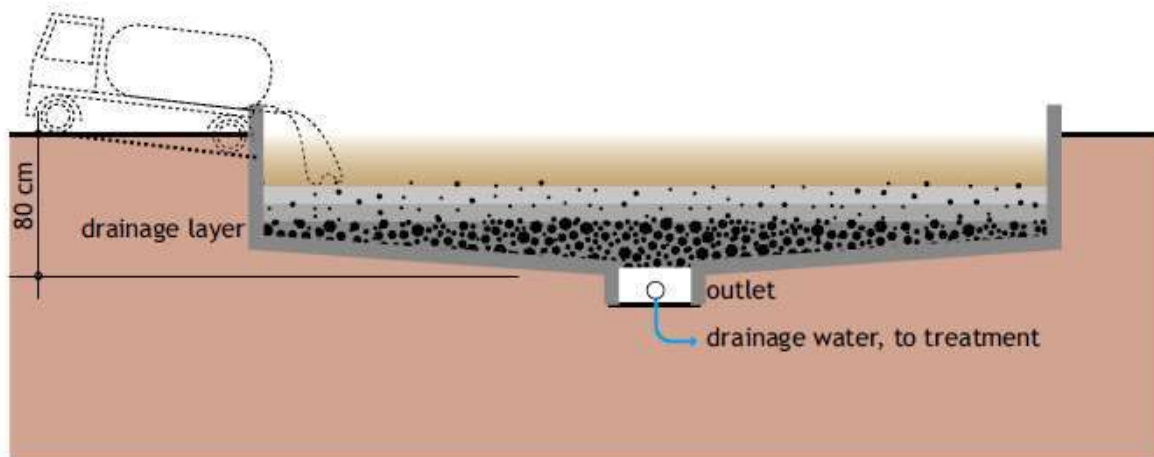

Figure 20: Schematic overview of an unplanted sludge drying bed (Tilley *et al.*, 2014).

The drying process is based on two principles. The first principle is percolation of the leachate through sand and gravel. This process is significant with sludge that contains large volumes of free water and is relatively fast, ranging from hours to days (Heinss *et al.*, 1998). The second process, evaporation, removes the bound water fraction and this process typically takes place over a period of days to weeks. Heinss *et al.* (1998) reported removal of 50 to 80% by volume due to drainage, and 20 to 50% due to evaporation in drying beds with FS. This range is typical for sludge with a significant amount of free water, but there is more evaporation and less percolation with sludge that has more bound water. For example, no leachate was observed in a study with preliminary thickened sludge (Badji, 2011). In planted sludge drying beds evapotranspiration also contributes to water loss.

### Unplanted sludge drying bed design parameters

When designing a drying bed, there are several influencing factors that need to be taken into consideration. These aspects vary from location to location, and can be grouped under climate factors and the type of sludge to be treated. Other key parameters that have an impact on the sludge drying process include the sludge loading rate, the thickness of the sludge layer, and the total bed surface. All these aspects are discussed in the following sections.

### Climate factors

Climate factors affecting the operation of unplanted drying beds include the following:

- Humidity: high humidity reduces the contribution of evaporation to the drying process;

- Temperature: higher temperatures, also in combination with relatively low humidity and high wind, will enhance the total amount of water removed via evaporation;
- Rainfall: in locations where rainfall is frequent and occurs for long periods of time intense, a drying bed may not be feasible. Pronounced rainy seasons can be accommodated for by not using the beds in that period, or by covering them with a roof. Rainfall will may rewet the sludge, the intensity of which depends on the phase of drying.

### Type of faecal sludge

The origin of the sludge is important when using drying beds. Septic tank sludge has less bound water and is hence more readily dewatered than fresh FS. In other words, it is considered to contain a lower specific sludge resistance for dewatering. It therefore can be applied in a thicker sludge layer or at a higher total solids loading rate or at a higher sludge loading rate. Sludge from public toilets is typically not digested: particles have not settled. Because it has a higher specific sludge resistance for dewatering less water will be removed, a longer sludge drying time may be required, or it may not be appropriate for drying beds.

Pescod (1971) carried out experiments with fresh pit latrine sludge on drying beds and obtained a wide variation in drying results – some comparable to more stable sludge. Generally, a proper solid liquid separation is difficult to obtain with fresh public toilet sludge. An alternative is to mix this type of sludge with older, more stabilised sludge (e.g. septic tank sludge) to enhance the dewaterability (Kone *et al.*, 2007; Cofie *et al.*, 2006).

### Sludge loading rate

The sludge loading rate (SLR) is expressed in kg TS/ m<sup>2</sup>/year. It represents the mass of solids dried on one m<sup>2</sup> of bed in one year. Pescod (1971) states that any general number linking the total amount of sludge to be dried to a sludge loading rate, bed surface area and loading depth can only be an estimate, as the local conditions vary greatly. However, it is possible to indicate a range of sludge loading rates which typically vary between 100 and 200 kg TS/m<sup>2</sup>/year in tropical climates, with 100 for poorer conditions and 200 for optimal conditions, while approximately 50 kg SS/m<sup>2</sup>/year is commonly used in temperate climates in Europe (Duchene, 1990). Poor conditions entail high humidity, low temperature, long periods of rainfall, and/or a large proportion of fresh FS. Optimal conditions comprise a low humidity, high temperature, a low amount of precipitation, and stabilised sludge. It may be possible in some cases to achieve an even higher sludge loading rate. Cofie *et al.* (2006) for example applied sludge at a loading rate of up to 300 kg TS/m<sup>2</sup>/year. Badji (2011) also found a SLR of 300 kg TS/m<sup>2</sup>/year to be effective for dewatering thickened FS with 60 g TS/L, while about 150 kg TS/m<sup>2</sup>/year was estimated to be an effective rate for a FS with 5 g TS/L in the same climatic conditions. Optimal local operating conditions need to be determined through pilot-scale experiments.

### Thickness of the sludge layer

A review of the literature shows that sludge is typically applied in a layer of 20 to 30 cm in depth, with a preference for 20 cm. It may seem a better option to apply a thicker sludge layer as more sludge can be applied to one bed; however, this will result in an increased drying time, and a reduction in the number of times the bed can be used per year. For any particular sludge dried under the same weather conditions, Pescod (1971) found that an increase in the sludge layer of only 10 cm prolonged the necessary drying time by 50 to 100%.

It is also important that the sidewalls of the drying beds are high enough to accommodate different loadings. For example, if a layer of 20 cm is applied with a water content of 90%, the initial height before the water is drained-off will be much greater than 20 cm. If the beds receive sludge discharged from a truck as opposed to settling tanks, the walls need to be higher than the planned 20 to 30 cm of sludge layer to allow for the increased volume of liquid.

### Number of beds

The number of beds required depends on the amount of sludge arriving at the plant per unit of time, the sludge layer thickness and the allowable sludge loading rate. For instance, for two weeks of drying duration and FS arriving 5 days per week, a minimum of 10 beds is required. The number of beds can then be increased or decreased considering the optimal sludge layer thickness. It is also important to adapt the number of beds based on the actual operating conditions, for example frequency of sludge removal, or frequency of rain. An increased number of beds increases the safety factor for adequate treatment with variable FS, or poor operation, but also increases capital costs. Cofie *et al.* (2006) utilised two beds of 25 m<sup>2</sup>, with a loading rate of 7.5 m<sup>3</sup> of sludge per bed at a loading depth of 30 cm.

### Summary of design parameters

It must be noted that the calculations and figures provided in this note have been provided based on as recommended by Pierre-Henri Dodane *et al* which were determined through local research for the local context based on sludge type and climate and therefore cannot be taken as applicable to all cases. However, they do provide examples of acceptable ranges, and an indication of the interdependency of the factors. In order to provide a suitable drying bed design, the design engineer needs to obtain local knowledge either from experience or from preliminary drying tests under local conditions. The first stage in conducting drying tests will be to determine the number of days required in order to obtain a desired total solids content of the sludge, or at least to obtain a sludge that can be readily removed. If for example the results from these drying tests indicate a two week drying period, including one day for loading and two days for removal, one bed can be filled 26 times per year. Further example calculations are given in illustrations to follow.

### Construction of an unplanted sludge drying bed

A drying bed treatment facility consists of the beds with an inlet and an outlet, a leachate collection and drainage system, a designated area outside of the beds for storage and continued drying of the

sludge, and potentially settling-thickening tanks. Sludge can be loaded directly from trucks onto the beds. In this case, various configurations exist such as creating one inlet for two beds, with a splitter to divide the sludge between the beds (Cofie *et al.*, 2006), by designing the bed with a ramp for the inlet of the sludge. Alternatively, a holding or settling tank can be installed into which the sludge is first discharged before being pumped into the drying beds. A splash plate must be used to prevent erosion of the sand layer and to allow even distribution of the sludge (Tilley *et al.*, 2008). This is crucial, as without a splash plate, the sand layer would be destroyed during the very first loading operation. Bar screens at the inlet are essential to keep rubble and trash present in the sludge from entering the bed. This is important to allow for proper use or disposal of the sludge after drying. The drying bed is typically a rectangular shape excavated from the soil, with a sealed bottom. As was shown in Figure 20, the bottom of the bed slopes downwards towards where the drainage system is installed such that the leachate can drain to the discharging point or further treatment. As the leachate is high in suspended solids, organic material, and nutrients, it needs to be treated before it can be discharged to the environment, according to the quality required for reclamation or for receiving water bodies.

#### Gravel and sand

Layers of gravel and sand are applied on top of the drainage system. When constructing drying beds, it is essential to use washed sand and gravel in order to prevent clogging of the bed from fine particles. This is important both for the initial construction, and for further supplemental additions of sand. The gravel layer functions as a support and there are typically two or three layers with two different diameters of gravel (Figure 20). The distribution of diameter size in the layers is based on avoiding clogging from small particles washing into the drain. The lower layer usually contains coarser gravel with a diameter of around 20-40 mm and the intermediate layer contains finer gravel with a diameter between the coarse gravel and the upper sand layer, for example 5-15 mm. Locally available materials will also have an influence on the design. For example, Cofie *et al.* (2006) made use of gravel with a diameter of 19 mm applied in a 15 cm supporting layer underneath 10 cm of gravel with a 10 mm diameter. To avoid the migration of particles from the sand layer into the gravel layers, a third layer of small gravel can also be used according to what is locally available, for example 2-6 mm.

A sand layer is placed on top of the gravel. The sand layer enhances drainage and prevents clogging, as it keeps the sludge from lodging in the pore spaces of the gravel. The diameter of the sand is crucial as sand with a larger diameter (1.0-1.5 mm) can result in the relatively fast accumulation of organic matter, thereby increasing the risk of clogging, the risk is reduced if sand with a smaller diameter (0.1-0.5 mm) is used (Kuffour *et al.*, 2009).

When selecting sand for the bed, it is important to note that the sand will need to be replaced occasionally, as a certain amount of the sand is bound to the sludge and will therefore be removed when the sludge is removed. It has been recommended by Pierre-Henri Dodane *et al.* that the sand that is chosen is easily obtained. Duchene (1990) reported a loss of a few centimetres of sand for each 5-10 drying sequences. In typical cases like at the Camberene FSTP in Dakar, 5 cm is lost after 25 drying sequences (Badji, 2008).

The sand also needs to be replaced when there is a build-up of organic matter and the bed starts to clog. Kuffour *et al.* (2009) observed a link between the rate of clogging and the rate of organic matter build-up on the sand. As organic matter builds up faster on sand with larger particles, a bed filled with larger diameter sand is more likely to clog. Cofie *et al.* (2006) had to replace the sand twice in a series of 8 dewatering cycles over 10 months due to clogging in a pilot scale implementation. For a full scale application, HPCIDBC (2011) estimated a sand exchange period of three years at a sludge loading rate of 250 kg TS/m<sup>2</sup>/year, a sludge filling height of 20 cm and a one week drying period (applicable to Nepali conditions).

### Sludge removal

In order for the sludge to be removed properly, it needs to be dry enough that it can be shovelled. Pescod (1971) carried out experiments with different types of sludge and treatment technologies, including lagoons and drying beds, and found sludge with a TS content of at least 25% fit for removal. The drying time of a specific sludge type depends on a number of factors, one of which is the sludge dewatering resistance. The higher the sludge dewatering resistance, the lower the drainage rate which leads to a prolonged drainage time. Sludge is removed mechanically or manually, with shovels and wheel barrows being the most common manual method.

In order to remove the sludge, a ramp must be provided to allow wheel barrows or other equipment to access the bed. If a drier sludge is required, this can be achieved by evaporation after it is removed from the drying bed. The dried sludge is frequently stored in heaps for periods of up to one year, during which time pathogen reduction can occur. It is, however, recommended that a more controlled treatment is employed in order to produce reliable and consistent end products.

Rewetting of the sludge is considered problematic if rainfall occurs before the free water of the sludge is completely drained. In this case, the moisture content of the sludge increases again and the drying period is prolonged. When the sludge is already dry enough to expose the sand layer through the cracks in the sludge, rain water can pass straight through the sludge and drains through the drying bed. CPHEEO recommends covering the beds with FRP canopy to avoid rewetting of the sludge. Sasse 1998 also recommends for roofing of drying beds in places receiving frequent rains. Therefore, if budget permits, this should be provided with steel framework to cover dried sludge during rainy days.

### Quality of dried sludge and leachate

The main purpose of a drying bed is to achieve dewatering; i.e. a physical separation between liquid and solids. Drying beds are therefore not designed with stabilisation or pathogen removal in mind, although some biodegradation may occur. Therefore, any pollutants present in the FS are not removed and either remain in the sludge or are present in the leachate.

|  | First day | Last day | Difference |
|--|-----------|----------|------------|
| pH                                     | 8.2       | 7.9      | -0.3       |
| EC ( $\mu\text{S}/\text{cm}$ )         | 21,900    | 11,400   | -10,500    |
| SS (mg/L)                              | 600       | 290      | -310       |
| COD (mg/L)                             | 5,600     | 3,600    | -2,000     |
| BOD (mg/L)                             | 1,350     | 870      | -480       |
| NH <sub>3</sub> -N (mg/L)              | 520       | 260      | -260       |
| TKN (mg/L)                             | 590       | 370      | -220       |
| NO <sub>3</sub> <sup>-</sup> -N (mg/L) | 50        | 170      | 120        |

Table 3: Typical characteristics of leachate from sludge drying beds (from Koné *et al.*, 2007)

Kone *et al.* (2007) carried out experiments with mixtures of septic tank and public toilet sludge, and analysed the leachate on the first and the last day of filtration for a variety of parameters. Although the measured concentrations were lower on the last day, the leachate was still far from environmentally safe for disposal with for example a BOD concentration of 870 mg/L. Hence, according to the final use or standards for receiving water bodies, the leachate should be collected and treated as a concentrated liquid waste stream, for example in ponds (Montangero and Strauss, 2002), or recovered for an appropriate end use.

Kone *et al.* (2007) also analysed FS from drying beds for *Ascaris* and *Trichuris* eggs. Sludge was applied in different ratios to unplanted sludge drying beds at a loading rate between 196 and 321 kg TS /m<sup>2</sup>/year, and left to dry until the TS content was at least 20%. Dewatering on the drying beds alone was not sufficient to inactivate all helminth eggs, and a total count of up to 38 *Ascaris* and *Trichuris* eggs was recovered after dewatering, of which 25–50% were viable (Kone *et al.*, 2007). This illustrates the need for additional storage time or other treatment options for increased pathogen reduction.

### **FACILITY DESIGN OF UNPLANTED SLUDGE DRYING BED:**

#### Sludge loading rate:

Sludge loading rate of 100 to 200 Kg TS / m<sup>2</sup> / year has been acceptable in tropical climates. In Sambalpur, where number of sunny days in a year can be more than 200 days, a higher loading rate can be adopted. However, based on observations in tropical countries, a loading rate of 150 Kg TS / m<sup>2</sup> / year may be safely adopted.

Sludge thickness: the range is 20 cms to 30 cms. A thickness of 20 cms may be adopted.

No of beds: This is to be designed based on the frequency of loading.

Sludge flow from the thickener: 7 m<sup>3</sup> / 10 days.

Each bed will be used two times in a month considering two weeks drying period.

Sludge concentration is 60 Kg TS/m<sup>3</sup> from settling-cum-thickening tank.

Sludge produced in a year =  $7 \times 3 \times 12 \times 60 = 15120$  Kg

With a loading rate of  $150 \text{ Kg} / \text{m}^2$ ,  $15120 / 150 = 101 \text{ m}^2$  of area is required.

Considering a sludge depth of  $0.2 \text{ m}$  and daily loading of  $0.7 \text{ m}^3/\text{day}$ , an area of  $3.5 \text{ m}^2 / \text{day}$  is required.

Bed L;B ratio may be taken as 5:1 (IS 10037, Pt-1).

Adopting a bed size of  $4\text{m} \times 10\text{m}$  i.e.  $40 \text{ m}^2$ , no of beds required =  $101/40 = 2.53$ .

Considering the sludge scraping time, rains, rewetting and drying time and in order to accommodation of overloading, 6 beds may be provided of  $40 \text{ m}^2$  size for higher efficiency. The beds may be arranged as twin type with central feeder pipes.

Drying bed wall: this may be constructed using RCC. The free board should be kept a minimum of  $0.3 \text{ m}$  above the final wet sludge surface. The floors can be built brick on edge and the underdrains can also be made of bricks (fly-ash bricks can be used). The slope towards the drains may be kept 1%. The underdrain width and height shall not be less than  $150 \text{ mm}$ . laterals can be made of brick on edge with a minimum width of one brick thickness i.e.  $75 \text{ mm}$  with a spacing of  $1 \text{ m}$  clear.

#### Sand and gravel:

Depth of sand bed should be  $0.15 \text{ m}$  or  $150 \text{ mm}$  with sand size in the range of  $0.5$  to  $1.0 \text{ mm}$  with uniformity coefficient not more than 4.

The gravel layer can be of  $300 \text{ mm}$  thick with two layers. Bottom layer having size between  $20$ - $40 \text{ mm}$  and top layer having size  $5$ - $15 \text{ mm}$ . however a  $50 \text{ mm}$  layer of  $2 \text{ mm}$  to  $5 \text{ mm}$  size gravel above the top layer should be laid to prevent carrying of finer particles of sludge deep into the gravel bed or washing away with the leachate.

Valves. Piping and splash plate etc. are also to be provided for smooth distribution, control and prevention of erosion of sand layer during loading respectively. Refilling of sand after every 25 scraping of sludge is recommended.

A pump of appropriate capacity is required to be installed in the leachate sump for recycling back to the settler-cum-thickener tank for treatment. The volume of sump =  $0.9 \times 7 = 6.3$  Say,  $7 \text{ m}^3$  may be provided. ( $2.0 \text{ m}$  dia x  $2.5 \text{ m}$  depth)

#### **DESIGN AND OPERATIONAL PRINCIPLES OF CO-COMPOSTING:**

Co-composting is the controlled aerobic degradation of organics, using more than one feedstock (faecal sludge and organic solid waste). Faecal sludge has a high moisture and nitrogen content, while biodegradable solid waste is high in organic carbon and has good bulking properties (i.e., it allows air to flow and circulate). By combining the two, the benefits of each can be used to optimize the process and the product.



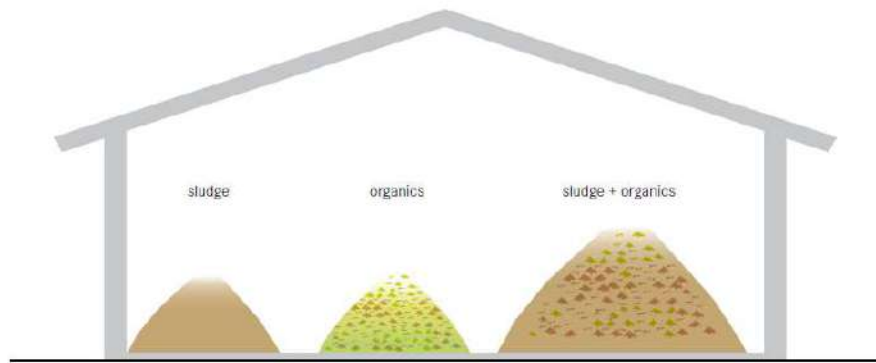

Figure 21: co-composting using bio-organics (Tilley *et al.*, 2014).

There are two types of co-composting designs: open and in-vessel. In open composting, the mixed material (sludge and solid waste) is piled into long heaps called windrows and left to decompose. Windrow piles are periodically turned to provide oxygen and ensure that all parts of the pile are subjected to the same heat treatment. In-vessel composting requires controlled moisture and air supply, as well as mechanical mixing. Therefore, it is not generally appropriate for decentralized facilities. Although the composting process seems like a simple, passive technology, a well-functioning facility requires careful planning and design to avoid failure.

**Design Considerations** The facility should be located close to the sources of organic waste and faecal sludge to minimize transport costs, but still at a distance away from homes and businesses to minimize nuisances. Depending on the climate and available space, the facility may be covered to prevent excess evaporation and/or provide protection from rain and wind. For dewatered sludge, a ratio of 1:2 to 1:3 of sludge to solid waste should be used. Liquid sludge should be used at a ratio of 1:5 to 1:10 of sludge to solid waste. Windrow piles should be at least 1 m high and insulated with compost or soil to promote an even distribution of heat inside the pile.

**Appropriateness** A co-composting facility is only appropriate when there is an available source of well-sorted biodegradable solid waste. Solid waste containing plastics and garbage must first be sorted. When carefully done, co-composting can produce a clean, pleasant, beneficial soil conditioner. Since moisture plays an important role in the composting process, covered facilities are especially recommended where there is heavy rainfall.

Apart from technical considerations, composting only makes sense if there is a demand for the product (from paying customers). In order to find buyers, a consistent and good quality compost has to be produced; this depends on good initial sorting and a well-controlled thermophilic process.

**Health Aspects/Acceptance** Maintaining the temperature in the pile between 55 and 60 °C can reduce the pathogen load in sludge to a level safe to touch and work with. Although the finished compost can be safely handled, care should be taken when dealing with the sludge, regardless of the previous treatment. If the material is found to be dusty, workers should wear protective clothing and use appropriate respiratory equipment. Proper ventilation and dust control are important.

**Operation & Maintenance** The mixture must be carefully designed so that it has the proper C:N ratio, moisture and oxygen content. If facilities exist, it would be useful to monitor helminth egg inactivation as a proxy measure of sterilization. A well-trained staff is necessary for the operation and maintenance of the facility. Maintenance staff must carefully monitor the quality of the input material, and keep track of the inflows, outflows, turning schedules, and maturing times to ensure a high quality product. Forced aeration systems must be carefully controlled and monitored.

Turning must be periodically done with either a front-end loader or by hand. Robust grinders for shredding large pieces of solid waste (i.e., small branches and coconut shells) and pile turners help to optimize the process, reduce manual labour, and ensure a more homogenous end product.

### **Plus & Minus**

- + Relatively straightforward to set up and maintain with appropriate training
- + Provides a valuable resource that can improve local agriculture and food production
- + A high removal of helminth eggs is possible (< 1 viable egg/g TS)
- + Can be built and repaired with locally available materials
- + Low capital and operating costs
- + No electrical energy required
  
- Requires a large land area (that is well located)
- Long storage times
- Requires expert design and operation by skilled personnel
- Labour intensive
- Compost is too bulky to be economically transported over long distances

### **FACILITY DESIGN FOR CO-COMPOSTING:**

A facility space preferably shaded and for 200 m<sup>2</sup> may be provided near to the entrance for co-composting purpose. The product can then be transported and used in the parks and other horticulture areas. The space is to be provided with a shade made of steel frame and GRP material allowing sunlight to the compost area. This facility is optional may be adopted based on market study.

### **DESIGN AND OPERATIONAL PRINCIPLES OF AEROBIC PONDS:**

One maturation pond shall be provided at the end of the stream to provide necessary polishing in the form of removal of *e-coli* from the effluent. The basic design principle suggested by Sasse shall be followed with the help of a spreadsheet calculation. Though the pond system i.e. aerobic and polishing ponds shall be designed, only the polishing pond shall be adopted for the construction purpose since a horizontal filter immediately precedes the maturation pond and the recommended loading rate of BOD<sub>5</sub> on the filter remains around 4 g/m<sup>2</sup>.day.

Aerobic ponds receive most of their oxygen via the water surface. For loading rates below 4 g BOD/m<sup>2</sup>.d, surface oxygen can meet the full oxygen demand. Oxygen intake increases at lower temperatures and with surface turbulence caused by wind and rain. Oxygen intake depends further on the actual oxygen deficit up to saturation point and thus may vary at 20°C between 40 g O<sub>2</sub> /m<sup>2</sup>.d for fully anaerobic conditions and 10 g O<sub>2</sub> /m<sup>2</sup>.d in case of 75% oxygen saturation.

The secondary source of oxygen comes from algae via photosynthesis. However, in general, too intensive growth of algae and highly turbid water prevents sunlight from reaching the lower strata of the pond. Oxygen “production” is then reduced because photosynthesis cannot take place. The result is a foul smell because anaerobic facultative conditions prevail. Algae are important and positive for the treatment process, but are a negative factor when it comes to effluent quality. Consequently, algae growth is allowed and wanted in the beginning of treatment, but not desired when it comes to the point of discharge, because algae increase the BOD of the effluent. Algae in the effluent can be reduced by a small last pond with maximum 1day retention time. Larger pond area - low loading rates with reduced nutrient supply for algae - are the most secure, but also the most expensive measure.

Aerobic stabilisation ponds for reasons of oxygen intake should be shallow but deep enough to prevent weed growth at the bottom of the pond. A depth of 90 cm to 1 m in warm climate and up to 1.2 m in cold climate zones (due to frost) is suitable. Deeper ponds become facultative or even anaerobic in the lower strata.

### **FACILITY DESIGN FOR POLISHING POND:**

The basic data required for analysis is the volume of flow and pollution load. Starting from these data, the “entrance parameter” is the wanted effluent quality (BOD<sub>out</sub>, cell F5). The HRT necessary to achieve a certain BOD removal rate depends on temperature. Sludge production may be high in aerobic ponds due to dead algae sinking to the bottom. Assuming a 20% total solids content in compressed bottom sludge and a 50% reduction of volume due to anaerobic stabilisation, almost 4 mm of bottom sludge per gram BOD<sub>5</sub> / m<sup>3</sup>.d, organic load would accumulate during one year. At loading rates of 15 g BOD<sub>5</sub> / m<sup>3</sup>.d, approximately 6 cm of sludge are expected per year. However, the sludge volume has not been taken into the calculation because the surface area plays the major role for dimensioning.

| GENERAL SPREADSHEET FOR AEROBIC-FACULTATIVE PONDS, INPUT AND TREATMENT DATA |   |   |                |                 |                          |                          |                     |                          |                         |                          |                     |
|---|---|---|----------------|-----------------|--------------------------|--------------------------|---------------------|--------------------------|-------------------------|--------------------------|---------------------|
| Daily Flow  | COD Inflow                              | BOD <sub>5</sub> Inflow                 | COD/BOD ratio  | Min. Water Temp | BOD <sub>5</sub> outflow | BOD <sub>5</sub> Removal | COD Removal         | COD Outflow              | HRT Factor              | HRT                      | Desludging Interval |
| data  | data                                    | data                                    | calc           | data            | chosen                   | calc                     | calc                | calc                     | calc                    | calc                     | data                |
| m <sup>3</sup> /day   | mg/l                                    | mg/l                                    | ratio          | mg/l            | mg/l                     | %                        | %                   | mg/l                     | %                       | days                     | months              |
| 18  | 15                                      | 9.5                                     | 1.58           | 20.0            | 5                        | 47.37%                   | 45%                 | 8                        | 0.3                     | 5.65                     | 12                  |
|   |   |   |                |                 |                          |                          |                     |                          | 0.05-1.0                |                          |                     |
| DIMENSIONS OF AEROBIC-FACULTATIVE PONDS                                     |   |   |                |                 |                          |                          |                     | POLISHING POND 1 DAY HRT |                         |                          | TOTAL               |
| Accumulated sludge volume   | Permitted Organic Load BOD <sub>5</sub> | Actual Organic Load (BOD <sub>5</sub> ) | Depth of ponds | Total Pond Area | Number of main ponds     | width of ponds           | length of each pond | Area of polishing pond   | width of polishing pond | length of polishing pond | Area of all ponds   |
| calc  | calc                                    | calc                                    | chosen         | calc            | chosen                   | chosen                   | calc                | calc                     | chosen                  | calc                     | calc                |
| m <sup>3</sup>  | g/m <sup>2</sup> .day                   | g/m <sup>2</sup> .day                   | m              | m <sup>2</sup>  | No                       | m                        | m                   | m <sup>2</sup>           | m                       | m                        | m <sup>2</sup>      |
| 0.120   | 19.31                                   | 1.91                                    | 1.00           | 89.32           | 3                        | 6.00                     | 4.96                | 18.00                    | 4.00                    | 4.50                     | 285.97              |
| 0.00411   | l/g BOD                                 |   | 0.9-1.2        |                 |                          |                          |                     |                          |                         |                          |                     |

Fig 22: Showing the Design dimensions of Pond System

**DIMENSIONING OF VARIOUS UNITS:**

1. Screen Channel: (2 nos.)

One sludge receiving chamber of 1.50 m x 1.50 m clear size will be provided  
0.6 m (0.3 m SWD) x 3.0 m

Bar screen 1 m wide x 1 m depth – MOC: SS 316

Angle of placement to horizontal 45°, placed on a support channel for easy maintenance.

Feeder channel and bar screen shall be built above ground.

Unloading height shall be between 2 to 3 meters above ground.

Channel to be supported on short columns

Material of construction: R.C.C (M25)

2. Settler-cum-thickener: (2 nos.)

L x B x D = 7 m x 2 m x 2.1 m (depth at outlet)

Bottom slope 2% reverse.

Pump / sludge pit size 1000 mm x 1000 mm

Material of construction: R.C.C (M25)

Construction is over ground provided the level permits.

Baffles to be placed at 1 m from both ends across the width for flow and scum control.

Emptying period is once every 10 days.

Emptying to be carried out through pump to the SDBs.

All piping shall not be less than 150 mm  $\phi$

Supernatant shall be withdrawn through gravity to the ABRs

Twin settlers to be provided with common header channel

Lime addition can be done in the header channel, if required.

A walking platform 1000 mm wide to be built all around the settler for maintenance.

3. Unplanted Drying Beds:(6 nos.)

Size: 4000 mm x 10000 mm

Nos: 6 numbers of bed to be provided.

Material of construction of walls: R.C.C (M25)

Material of construction of floors: Fly-ash bricks on edge

Underdrains dimension: 150 mm, brick on edge

Laterals: 75 mm channels placed @ 1 m intervals.

Bed slope of 1% towards the underdrain.

Size of piping up to the leachate sump: 150 mm

Depth of sand bed: 150 mm

Size of sand: 0.5 to 1 mm with UC not more than 4

Depth of gravel bed: 300 mm

Size of gravel: 20-40 mm in bottom half and 5 to 15 mm on top half

Sloped part may be covered with perforated slabs on which the gravels can be placed.

Size of perforated slabs: 1000 mm x 1000 mm x 100 mm

Size of perforation: 20-25 mm

Splash plate of 0.6 m x 1.0 m to be provided on the sand bed at the pipe discharge point.

MOC of splash plate: SS 304 with a minimum thickness of 6 mm to be fixed to the walls through brackets which can be removed during maintenance. The clearance of splash plates from the sand bed shall be 25 mm.

All piping to the SDB shall be 100 mm size and of HDPE material.

All valves shall be of DI make.

The beds are of twin type with central feeder pipes.

#### 4. Anaerobic Baffled Reactors: (2 nos.)

Dimension: 11000 mm x 2000 mm x 2000 mm (1750 mm SWD)

Settler size: 4000 mm x 2000 mm

Up-flow reactor chamber size: 1175 mm x 2000 mm x 1750 mm SWD

Shaft width: 300 mm

MOC: R.C.C (M25), all piping HDPE of 150mm size.

To be built under ground with roof above ground level.

Number of reactor compartments = 5

Size of manhole: 600 mm x 600 mm, all reactors compartments shall have manholes for sludge removal.

Twin tanks of above size with common central wall shall be provided.

Adequate ventilation through piping shall be provided.

The ABRs shall be fed through gravity from the thickener tanks through piping of size not less than 150 mm with provision of DI valves. All piping inside ABR shall be of HDPE type. Details provided in the literature shall be followed while construction. Two extra cells within the ABR may be added for anaerobic filtration.

#### 5. Planted Gravel Filters (Horizontal) (1 no)

Area: 500 m<sup>2</sup> (25 m x 20 m)

Slope: 1%, depth at entrance: 0.6 m

COD and BOD<sub>5</sub> out flow: **15 and 9.5** respectively.

40 m wide channel with 50 mm opening shall be used across the width for even distribution of flow to the wetland.

Start depth of 0.6 m and end depth of 0.9 m shall be provided.

Bottom of the wetland may be made of brick flooring with brick on edge.

Washed gravel of size 5 mm – 30 mm shall be provided on the bed.

Water level at 150 mm below the surface shall be maintained.

Phragmites australis (reed) is a common choice to be planted since it forms horizontal rhizomes that penetrate the entire filter depth

The effluent shall be used for irrigation of parks etc.

6. Polishing Pond: (1 no)

Pond area = 18 m<sup>2</sup>, size: 4 m x 4.5 m

Pond depth = 1.0 m

Brick lining with cement plaster may be provided on the bank for slope protection.

A pump shall be installed for collection of effluent and for further disposal.

7. One leachate sump of 2.0 m dia and 2.50 m deep of RCC with top cover may be provided along with pumping arrangement for feeding to the ABR.

8. Other Ancillary Units:

1. Space for co-composting: a minimum of 200 m<sup>2</sup> shall be provided
2. Guard room of 10 m<sup>2</sup> size shall be provided.
3. One production well and one overhead tank of 5000 litres capacity shall be provided.
4. One room 4 m x 6 m size for laboratory equipment purpose shall be provided.
5. One equipment room along with administrative room of size 4 m x 10 m shall be provided for administrative purpose.
6. Since only panels are installed (in case of submersibles), the total pump room area for leachate, sludge and final effluent may be restricted to 12 m<sup>2</sup>.
7. One electrical sub-station of appropriate size.

### **STRUCTURAL DESIGN OF COMPONENTS:**

The major components which shall require a structural detailing are;

1. Screen channel
2. Settling cum thickening tank
3. Anaerobic baffled reactor

The minor components which need to be detailed from construction point of view are;

1. Unplanted Drying Beds
2. Horizontal constructed wetland

Also certain ancillary items are required to support the operational requirement of the septage plant.

They are;

1. Building of about 75 m<sup>2</sup> area
2. One 800 mm size deep production well and one 5000 litres capacity GRP / HDPE / UPVC overhead tank installed on the building roof.

### **Design Consideration:**

1. The settling tank shall be designed partly underground (the hopper part) and shall be subject to active earth pressure. Therefore, the wall shall be subject to moments with restraint bottom. Ordinarily, in non-traffic sections there will not be any surcharge load due to traffic.
2. In case of ABR, the tanks shall be designed as vessels in series and underground. The inner partitions are subject to water load on one side. The outer walls are subject to active earth load under tank empty conditions. All wall and partitions shall be RCC.
3. The minimum SBC of the soil has been considered to be more than 50.00 kN/m<sup>2</sup>. In case of drying bed, it has a large area for distributing the load, hence it is generally considered safe against settling.
4. Wall section of each channel is designed to establish the structural dimensions. The design is based on limit state method and the sections are designed under the limit state of serviceability.
5. The entire internal area is plastered (Base, Wall) in order to avoid honeycomb and rough patches that may affect the Manning's co-efficient adopted in the hydraulic design. C.I or any durable type rungs are provided on the wall section for ease of entry.



6. Following design principles and data are considered for design of the section;

|  |   |
|--|---|
| a. Grade of concrete:                                | M25   |
| b. Grade of steel:                                   | F <sub>e</sub> 500  |
| c. Angle of internal friction, $\Phi$ :              | 33°   |
| d. Active Earth Pressure Co-efficient:               | $1 - \sin \Phi / 1 + \sin \Phi = 0.33$                        |
| e. Soil Density:                                     | 19 kN/m <sup>2</sup>  |
| f. $X_{u, \max} / d$ for M25: for F <sub>e</sub> 500 | 0.46  |
| g. Factored load for steel at collapse:              | 1.15  |
| h. Factored load for concrete at collapse:           | 1.5   |
| i. SBC of soil:                                      | > 50 kN/m <sup>2</sup> (50 kN/m <sup>2</sup> adopted)         |
| j. $M_{u, \text{lim}}$ for balanced section:         | $0.36f_{ck}(X_{u, \max} / d)(1 - 0.416 X_{u, \max} / d) bd^2$ |
| k. Minimum surcharge loading on walls:               | 20 kN/m <sup>2</sup>  |
| l. $R_u$ , section constant for F <sub>e</sub> 500:  | $0.1339 f_{ck}$   |
| m. $M_u / bd^2$ :                                    | $0.87f_y(1 - f_{yp} / f_{ck})$                                |
| n. For axially loaded short columns, $P_u$           | $0.4f_{ck}.A_c + 0.67f_y.A_{sc}$                              |

### **Screen Channel:**

#### **Wall:**

The screen channel will be supported on a short column with a maximum spacing of 3 meters.

|                                |   |
|--------------------------------|---|
| Depth of channel:              | 600 mm  |
| Clear width:                   | 300 mm  |
| Assume side wall thickness, D: | 100 mm  |
| Water pressure:                | $0.6 \times 10 = 6 \text{ kN} / \text{m}^2$                         |
| Max moment on the wall:        | $0.33 \times 0.5 \times 6 \times 0.6 = 0.594 \text{ kN} - \text{m}$ |
| $M_u$ :                        | $0.594 \times 1.5 = 0.891 \text{ kN} - \text{m}$                    |
| $d_u$ :                        | $\sqrt{(0.891 \times 1000 / 3.348)} = 16.31 \text{ mm}$             |

by placing the steel at the center of the section,  $d_u = 50 \text{ mm}$

$$M_u / bd^2 = 0.891 \times 1000 / 50^2 = 0.3564, P_t = 0.082 \text{ (Table - 3, SP-16)}$$

$$\text{Tensile reinforcement, } A_{st} = 0.082 \times 1000 \times 100 / 100 = 82 \text{ mm}^2$$

$$\text{Minimum tensile reinforcement} = 0.85 \times 1000 \times 100 / 500 = 170 \text{ mm}^2$$

Provide minimum reinforcement using #8 mm bars @  $50.24 \times 1000 / 170 = 295.5 \text{ mm c/c}$

Actual spacing @ 250 mm c/c may be provided.

Transverse bars at same spacing may be provided.

#### **Base slab:**

$$\text{Width of slab} = 300 + 200 = 500 \text{ mm}$$

$$\text{Udl on slab} = 0.3 \times 0.6 \times 10 + 0.2 \times 0.5 \times 25 + 0.1 \times 2 \times 0.6 \times 25 = 7.3 \text{ kN/m}$$

Consider maximum span of slab = 3.0 m

$$\text{Moment, } M = 7.3 \times 3^2 / 8 = 8.2125 \text{ kN.m}$$

$$M_{\text{ultimate}} = 1.5 \times 8.2125 = 12.32 \text{ kN.m}$$

$d_u = \sqrt{(12.32 \times 1000 / 3.348)} = 60.66$  mm, provide an overall depth of 150 mm,

$d_u = 75$  mm,  $M_u/bd^2 = 12.32 \times 1000 / 75^2 = 2.19$ ,  $P_t = 0.569$  (Table – 3, SP-16)

$A_{st} = 0.569 \times 1000 \times 75 / 100 = 426.75$  mm<sup>2</sup>

Using # 10 mm bars, spacing =  $78.5 \times 500 / 426.75 = 91.97$  mm, provide @ 75 mm c/c.

Transverse bars of # 8 mm may be provided @ 250 mm c/c

### Cantilever Beam:

Two channels will be provided without any gap i.e. with one common partition wall of 100 mm thick RCC. Member.

Length of cantilever =  $50 + 300 + 100 = 0.45$  m

Assuming a 200 x 200 section

Superimposed load on each column =  $(3 \times 0.15 \times 0.9 \times 25 + 3 \times 0.1 \times 0.6 \times 3 \times 25 + 0.2 \times 0.2 \times 0.9 \times 2 \times 25 + 0.6 \times 0.6 \times 10 \times 3) / 2 = 18.11$  kN

Udl on one cantilever =  $18.11/0.45 = 40.25$  kN/m

Max moment =  $40.25 \times 0.45^2 / 2 = 4.075$  kN.m

$M_u = 1.5 \times 4.075 = 6.11$  kN.m,  $d_u = \sqrt{(4.075 \times 10^6 / 200 \times 3.348)} = 78$  mm

Effective depth taken =  $200 - 50 - 6 = 144$  mm (OK)

$M_u/bd^2 = 4.075 \times 10^6 / 200 \times 144^2 = 0.983$ ,  $P_t = 0.23$ ,  $A_{st} = 0.23 \times 200 \times 144 / 100 = 66.24$  mm<sup>2</sup>

Provide #12 mm 3 nos,  $A_{st} = 3 \times 113 = 339$  mm<sup>2</sup> (OK)

# 8 mm 2-legged stirrups may be provided @ 200 mm c/c.

### Design of column:

Height of the column = 1.5 m

Section: 250 mm x 250 mm

Load on each column =  $18.11 + 1.5 \times 0.0625 \times 25 = 20.45$  kN

$e_{min} = (l/530) + (D/30) = (1500/530) + (250/30) = 11.16$  mm

Minimum eccentricity =  $0.05D = 0.05 \times 250 = 12.5$  mm which is within 20 mm. (Clause 25.4, IS 456/2000)

$P_u = 0.4f_{ck} \cdot A_c + 0.67f_y \cdot A_{sc}$

$1.5 \times 20.45 \times 10^3 = 0.4 \times 25 \times (250 \times 250 - A_{sc}) + 0.67 \times 500 \times A_{sc}$

$\Rightarrow 30675 = 625000 - 10A_{sc} + 335A_{sc}$

The above equation provides a negative  $A_{sc}$  which means, the concrete can take the entire load.

However, minimum reinforcement of 0.8% is to be provided.

$A_{sc} = 0.008 \times 250^2 = 500$  mm<sup>2</sup>, #16 mm bars 2 nos and #12 mm 2nos may be provided.

#8 mm tie may be provided @ 150 mm c/c

### Isolated footing of uniform depth:

Load,  $W = 20.45$  kN,  $W' =$  weight of footing = 20% of  $W = 6.09$  kN

Footing area 'A' =  $(20.45 + 6.09) = 26.54$  kN / 50 =  $0.53$  m<sup>2</sup> =  $0.73$  m x  $0.73$  m

Provide 1.0 m x 1.0 m area.

Net upward pressure under factored load  $P_{0u} = 1.5 \times 20.45 / 1 = 30.675 \text{ kN/m}^2$

$X_{u,max}/d = 0.46$  for  $F_e = 500$

$R_u = 0.36 \times 25 \times 0.46(1 - 0.416 \times 0.46) = 3.3478$

$M_u = P_u \times (B/8) \times (B - b)^2 \times 10^6 = \text{N-mm}$

$= 30.675 \times 1/8 \times (1 - 0.25)^2 \times 10^6 = 2.16 \times 10^6 \text{ N-mm}$

$d_u = \sqrt{[(2.16 \times 10^6) / (3.3478 \times 1000)]} = 25 \text{ mm}$  which is small.

We shall therefore provide an overall thickness of 300 mm and 0.12% steel in the base.

Allowable load transfer at base  $\sqrt{A_1/A_2} = 2$

$A_1 = 62500 \text{ mm}^2$ ,  $A_2 = [250 + 2 \times (2 \times 300)]^2 = 2102500 \text{ mm}^2$

$\sqrt{A_1/A_2} = 1 < 2$  OK

Permissible bearing stress  $= 0.45 \times f_{ck} \times \sqrt{A_1/A_2} = 0.45 \times 25 \times 1 = 10 \text{ N/mm}^2$

Actual bearing pressure  $= 30.68 \times 1000 / 250^2 = 0.49 \text{ N/mm}^2$ , hence safe.

### Design of settling tank:

Length of tank = 7 m, width = 2 m, SWD = 2.1 m

Concrete M25,  $\sigma_{cbc} = 8.5 \text{ N/mm}^2$ ,  $m = 280 / (3 \times 8.5) = 10.98$ ,  $\sigma_{st} = 130 \text{ N/mm}^2$

$k = (10.98 \times 8.5) / [(10.98 \times 8.5) + 130] = 0.418$

$j = (1 - k/3) = 0.861$ ,  $R = 0.5 \times 8.5 \times 0.418 \times 0.861 = 1.53$

L/H = 3.3, B/H = 1 values beyond 3 for L/H is not available in IS 3370 Pt-4.

Hence analysis, based on approximate method, shall be carried out.

#### Long wall:

Water load at base =  $10 \times 2 = 20 \text{ kN/m}^2$ , the walls shall be subject to a cantilever moment with max value at base =  $10 \times 2^3 / 6 = 13.33 \text{ kN-m}$

Direct tension on the long walls =  $10 \times (2 - 2/4) \times 2/2 = 15 \text{ kN}$

$d = \sqrt{(13330 / 1.53)} = 93 \text{ mm}$

Provide a thickness of 250 mm at base uniformly tapered to 150 mm at the top.

The short walls will also have the same dimensions.

Weight of walls =  $2 \times 0.2 \times 7 \times 25 \times 2 + 2 \times 0.2 \times 2 \times 25 \times 2 + 20\% \times (2 \times 0.2 \times 7 \times 25 \times 2 + 2 \times 0.2 \times 2 \times 25 \times 2) + 2 \times 7 \times 10 \times 2 + 0.2 \times 14 \times 25 = 566 \text{ kN}$

Area of tank =  $24 \text{ m}^2$ , pressure =  $566 / 14 = 40.42 \text{ kN / m}^2 < 50 \text{ kN / m}^2$  (OK)

Max horizontal moment in short wall =  $10 \times (2 - 0.5) \times 2^2 / 16 = 3.75 \text{ kN-m} < 13.33$ , hence the vertical moment is governing.

Max cantilever moment at 1 m in short wall =  $10 \times 2 \times 0.5^2 / 6 = 0.833 \text{ kN-m}$ , small.

Pull on long wall =  $10 \times (2 - 0.5) \times 1 = 15 \text{ kN}$

Pull on short wall =  $10 \times (2 - 0.5) \times 1 = 15 \text{ kN}$

#### Reinforcement for long walls:

Fixing moments for short walls =  $10 \times (2 - 0.5) \times 2^2 / 16 = 3.75 \text{ kN-m}$

Direct tension =  $10 \times 1.5 \times 1 = 15 \text{ kN}$ , lever arm,  $x$  for tensile force =  $200 - 250/2 = 75 \text{ mm}$

$A_{stb} = 13.33 \times 1000 \times 1000 / (130 \times 0.861 \times 220) = 541 \text{ mm}^2$

Tensile steel in long wall =  $15 \times 1000 / 130 = 115 \text{ mm}^2$

Minimum steel in horizontal direction =  $0.0012 \times 1000 \times 200 = 240 \text{ mm}^2$

**Provide vertical steel # 12 mm bars, at 208 mm c/c, provide at 200 mm c/c.**

**Provide horizontal steel # 8 mm at 209 mm c/c, provide at 200 mm c/c**

Reinforcement for short wall:

Moment in short wall in horizontal direction =  $10 \times 1.5 \times 2^2 / 16 = 3.75$  kN-m, low.

**The same reinforcement as provided for the long wall shall also be provided in the short wall.**

Max bending tension =  $13.33 \times 1000 \times 6 / 220^2 = 1.65$  N/mm<sup>2</sup>

Max direct tension =  $15000 / (1000 \times 200) = 0.075$  N/mm<sup>2</sup>

$(1.65/1.8) + (0.075/1.3) = 0.974 < 1$  (OK)

Reinforcement on both faces and both direction should be provided at the above spacing in a staggered fashion.

The base slab shall transmit water load direct to the soil.

The slab thickness may be adopted as 250 mm with nominal reinforcement using #10 mm bars @ 200 mm c/c on both directions at bottom face.

Anaerobic Baffled Reactor Tank:

The tank shall be built as independent cells placed adjacent to each other. The first cell is the settler and the rest five cells are the reactors.

Settler:

Size: 4.00 m x 2.00 m, L/B = 2, L/H = 4/2 = 2 (IS 3370 Pt-4, 1999)

Considering top free and all three edges fixed for the wall panel, max vertical and horizontal moments at b/a = 2 are,  $0.086 \times 10 \times 2^3 = 6.88$  kN-m,  $0.074 \times 10 \times 2^3 = 5.92$  kN-m respectively.

Vertical moment being governing,  $d = \sqrt{6.88 \times 1000 / 1.53} = 67$  mm

Provide 200 mm overall thickness with  $d = 200 - 40 - 5 = 155$  mm

$A_{st} = 6.88 \times 10^6 / (130 \times 0.861 \times 155) = 396.56$  mm<sup>2</sup>

Using #10 mm bars, spacing =  $78.5 \times 1000 / 396.56 = 197.95$  mm c/c

**Provide # 10 mm @ 200 mm c/c on both faces and both directions in staggered manner.**

Reactor cells:

Size: 4.00 m x 1.175 m, L/B = 4/1.175 = 3.404 > 3

Long walls (partitions) are designed as cantilevers.

Vertical moment =  $10 \times 2^3/6 = 13.33$  kN-m

Overall thickness = 200 mm

**Provided # 10 mm bars @ 200 mm c/c on both faces and directions.**

Baffles with nominal reinforcement and 100 mm thick shall be provided wherever necessary.

Roof slab of ABR settler:

L/B = 2, slab spanning in both directions.

End condition for settler: Slab freely supported on three edges and continuous over the other.

$M_x = 0.097 \times w l_x^2$  (IS 456/2000)

W = dead load (0.125 x 25) + live load (5) + finishing load (1) = 9.125 kN/m<sup>2</sup>

$M_x = 0.097 \times 9.125 \times 2^2 = 3.54$  kN-m (maximum of all moments)

$d_e = \sqrt{(3.54 \times 1000 / 1.53)} = 48$  mm, provide overall depth, D = 100 mm

$A_{st} = 3.54 \times 10^6 / (130 \times 0.861 \times 70) = 451.8$  mm<sup>2</sup>

$A_{st, min} = 0.0012 \times 1000 \times 100 = 120$  mm<sup>2</sup>

Provide # 10 mm bars. Spacing =  $78.5 \times 1000 / 451.8 = 173.75$  mm, provide at 150 mm c/c. Provide on both faces. 50% extra may be provided on top face at l/8 over the continuous edges.

Base Slab:

Base slab will transmit entire water load to the soil. A 250 mm thick slab with 0.12% reinforcement will be sufficient for flexural strength of the slab.

$$A_{st} = 0.0012 \times 250000 = 300 \text{ mm}^2, \text{ spacing} = \# 10 \text{ mm @ } 78.5 \times 1000 / 300 = 261.6 \text{ mm.}$$

Provide @ 250 mm c/c.

Drying Beds:

All drying beds shall be placed adjacent with common separator walls over continuous footings.

The walls are not subject to any lateral load except while emptying the whole bed.

$$\text{Wall height} = \text{sand (150 mm)} + \text{Gravel (300 mm)} + \text{sludge (200 mm)} + \text{free board (300 mm)} = 950 \text{ mm}$$

Provide a wall thickness of 200 mm.

$$\text{Provide nominal reinforcement} = 0.0012 \times 1000 \times 200 = 240 \text{ mm}^2$$

Provided # 8 mm bars on both faces.

Steel,  $A_{st}$  on each face =  $50.24 \times 1000 / 120 = 418 \text{ mm}$ , provide at 250 mm c/c on both faces and directions.

Provide a footing width of 600 mm of 200 mm uniform depth. Base reinforcement may be provided with # 8 mm bars @ 250 mm c/c on both directions.

Horizontal Gravel Filter:

Dimension: 25 m x 20 m x 1 m

5 m x 5 m floor panels may be provided with proper jointing and sealing.

Nominal reinforcement may be provided using # 8 mm bars @ 300 mm c/c with reinforcement continuous. Brick on edge flooring can also be taken up. The walls may be made 150 mm thick.

$$\text{Lateral saturated earth pressure} = 0.33 \times 19 \times 1 = 6.27 \text{ kN/m}$$

$$\text{Moment } M_b = 0.33 \times 0.5 \times 1 \times 6.27 = 1.03 \text{ kN-m/m}$$

$$M_{ub} = 1.5 \times 1.03 = 1.55 \text{ kN-m}$$

$$M_u/bd^2 = 1.55 \times 1000 / 75^2 = 0.276, P_t = 0.12\%, \text{ minimum}$$

Provide nominal reinforcement using # 8 mm bars @  $50.24 \times 1000 / (0.0012 \times 1000 \times 150) = 279 \text{ mm}$

Provide @ 250 mm c/c at the center of section.

Wall panels of 3 m length may constructed with vertical joints to allow expansion.

Appropriate joint filler shall be provided.

The wall footing shall be of 150 mm section with nominal reinforcement as that in the wall.

Removable cover slabs wherever provided shall be of 75 mm thick and size not exceeding 1200 mm x 600 mm with nominal reinforcement. In case of cover slabs having length  $\geq 2000 \text{ mm}$ , the thickness should be increased to 100 mm with consideration of live load of  $5 \text{ kN/m}^2$ . However, the width should not exceed 750 mm for ease of removal and handling.

## **ECONOMIC AND FINANCIAL ASPECTS**

For any project to be economically viable, its financial status needs to be analysed. According to market principles and growth of economy it is necessary that any investment shall produce some tangible benefits in financial terms. The benefits may be direct or indirect and these are to be examined with relation to the investment made in the project. Even though wastewater treatment may not produce appreciable financial viability, the methods of economic analysis such as cost-benefit or break-even point, are important, and requires to be worked out to examine the future sustainability of the project. The annual cost method, which includes depreciation on capital investment and operational costs, appears to be more apt as an economic indicator. With this method it is easy for the polluter to include expenses such as discharge fees, or income from reuse of by-products on an annual base, to get a comprehensive picture of the economic implications.

The annual cost method could also be used for estimating social costs and benefits. The economic impact of treatment on the environment and on public health is related primarily to the context in which a treatment plant operates. For example, if properly treated wastewater is discharged into a river that is already highly polluted the yield from fishing will surely not improve. On the contrary, if all the inflows into the receiving water were to be treated to the extent that the self-purifying effect of the river would allow the fish to grow, this would have considerable economic impact. This economic impact of a cleaner river is crucially dependent on the total number of treatment plants installed along the river, and not only on the efficiency of one single plant. Similarly, in arid and semi-arid areas, use of effluent for land irrigation can considerably improve the economy and growth.

### **Capital Cost:**

#### **a. Cost of Land**

Available literature on the subject reveals that for economic calculation the value of land remains the same over years and thus, land has unlimited lifetime. However, the price of land is never stable. It usually goes up in times of growth and may go down in times of political turbulence. In reality, the actual availability of land is far more important than the price; new land will rarely be bought only for the purpose of a treatment plant. The density of population usually determines the price of land. Land is likely to cost more in areas with a high population density and vice versa. The choice of treatment system is severely influenced by these facts.

In reality, the cost of land may or may not be essential to the comparison between different treatment systems. Wide differences in the cost of land notwithstanding, it may contribute in the range of 80% of the total cost of construction. It follows that at least in theory, the choice of sand filters and of ponds will be more affected by the price of land than compact anaerobic digesters. In any case, it is most likely that where land prices are high, compact tanks - not ponds and filters - will be the natural choice. *Alaerts et al* assume that ponds are the cheapest alternative when the cost of land is in the range of less than 15 US\$/m<sup>2</sup> in case of post treatment and 3 - 8 US\$/m<sup>2</sup> in case of full treatment. Such figures nonetheless have always to be checked locally.

## **b. Cost of Construction**

Annual costs are influenced by the lifetime of the hardware. It may be assumed that building and ground structures have a lifetime of 20 years; while filter media, some pipelines, manhole covers, etc. are only likely to last for 10 years. Other equipment such as valves, gas pipes, etc., may stay durable for 6 years. Practically it suffices to relate any structural element to any one of these three categories. It is assumed that full planning costs will reoccur at the end of the lifetime of the main structure, i.e. in about 20 years. In any individual case, the costs of planning can be estimated. For dissemination programmes, it may be assumed that planning will be carried out by a local engineering team of sound experience to whom the design and implementation of DEWATS is a routine matter. However, this might not be so in reality. At the contrary, of all costs, engineering costs are likely to be the most exorbitant and to remain so until such time as the level of local engineering capacity improves. An estimation of planning workdays for senior and junior staff forms the basis of calculation to which 100% may be added towards acquisition and general office overheads. Transport of personnel for building supervision and sample taking - and laboratory cost for initial testing of unknown wastewater's must also be included.

## **c. Running Costs**

Running expenses include the cost of personnel for operation, maintenance and management, including monitoring. Cost may be based on the time taken by qualified staff (inclusive of staff trained on the job) to attend to the plant. The time for plant operation is normally assessed on a weekly basis. In reality, the time estimated for inspection and attendance would hardly call for additional payment to those staff who are permanently employed. The case would be different for service personal that is specially hired. Facilities that are shared, as in the case of 5 to 10 households joining their sewers to one DEWATS, are likely to be 10% cheaper than individual plants. However, operational reliability of such a facility cannot be guaranteed if someone is not specially assigned to the task of maintenance. Cost for regular attendance could be higher for open systems such as ponds or constructed wetlands due to the occasional damage or disturbance by animals, stormy weather or falling leaves. The cost of regular de-sludging will be higher for tanks with high pollution loads, than for ponds which receive only pre-treated wastewater. The cost of cleaning the filter material is not considered to be running cost as these costs are taken care off by the reduced lifetime of the particular structure. So also the cost of energy and chemicals that are added permanently are not included, as such costs are not typical of DEWATS.

## Income from Wastewater Treatment

The calculation of income from by-products or activities related to wastewater treatment calls for careful selection of the right economic parameters. In case of septage biogas is not an option since the septage is partly digested and has lost most of its potential in producing the bio-gas. Therefore, the income may have to be channelized trough sale of effluent and dried sludge as fertilizer / manure. The size and organisation of the farm together with the marketing of the crops would be important parameters to consider.

Under the current context it is required to have a through market study on the potential demand for use of effluent and dried sludge. As an interim, the effluent may be used for irrigation of parks with treatment and sludge as manure to be used in public parks etc.



**ABSTRACT**

| <b>Sl. No.</b> | <b>Component</b>                                   | <b>Amount (Rs)</b>            |
|----------------|--|-------------------------------|
| <b>A</b>       | <b>Capital Works</b>                               |                               |
| 1              | Sludge receiving chamber (1.5m x 1.5m x 1.5m)      | 101300.00                     |
| 2              | Screen Chamber                                     | 113200.00                     |
| 3              | Settling -cum- Thickening Tank                     | 806100.00                     |
| 4              | Hybrid ABR + AF                                    | 1112200.00                    |
| 5              | Planted Horizontal Gravel Filter                   | 2202000.00                    |
| 6              | Unplanted Drying bed                               | 1993600.00                    |
| 7              | Maturation Pond with cost of pumps                 | 245000.00                     |
| 8              | Other Ancillary Units                              | 12588000.00                   |
|                | <b>Sub total</b>                                   | <b>19161400.00</b>            |
|                | Add 1% contingency                                 | 191614.00                     |
|                | <b>Total (A)</b>                                   | <b>1,93,53,014.00</b>         |
|                | <b>Operation &amp; Maintenance for 5 years (B)</b> | 8940475.00                    |
|                | <b>Grand Total</b>                                 | <b>28293489.00</b>            |
|                |  | <b>Say Rs. 2,82,93,000.00</b> |

**(Rupees two core eighty two lakh ninety three thousand) only**



|  |  |  |  |  |     |  |     |                    |           |  |  |
|--|--|--|--|--|-----|--|-----|--------------------|-----------|--|--|
| Add for earth work, back filling & disposal of surplus |  |  |  |  |     |  |     |                    |           |  |  |
| earth 15% of civil work                                |  |  |  |  |     |  | Rs. | 3,218.47           |           |  |  |
|  |  |  |  |  |     |  |     |                    |           |  |  |
| Add cost of cost of bar screen (1 m x 1 m) =           |  |  |  |  |     |  |     | Rs.                | 88,500.00 |  |  |
|  |  |  |  |  |     |  |     | 113174.91          |           |  |  |
|  |  |  |  |  |     |  |     |                    |           |  |  |
|  |  |  |  |  | Say |  | Rs. | <b>1,13,200.00</b> |           |  |  |

| <b>Settling cum Thickening Tank</b>                                  |  |  |   |     |  |  |     |                  |            |  |
|--|--|--|---|-----|--|--|-----|------------------|------------|--|
| <b>RCC M25</b>   |  |  |   |     |  |  |     |                  |            |  |
|  |  |  |   |     |  |  |     |                  |            |  |
| Baffle wall  |  | 2 x 2 x 2 m x 0.6 m x 0.1                        | = |     |  |  |     | 0.48             | cum        |  |
| Tank wall  |  | 2 x 2 x (7.2m + 2.2m) x 2.1m x 0.2m              | = |     |  |  |     | 15.79            | cum        |  |
| Tank Base  |  | 2 x 7.4m x 2.4m x 0.25m                          | = |     |  |  |     | 8.88             | cum        |  |
|  |  |  |   |     |  |  |     | <b>25.15</b>     | <b>cum</b> |  |
|  |  | @ Rs. 5815.00/cum                                | = | Rs. |  |  |     | 146247.25        |            |  |
| <b>Centering &amp; Shuttering</b>                                    |  |  |   |     |  |  |     |                  |            |  |
| Wall Quantity = 16.27 cum  |  |  |   |     |  |  |     |                  |            |  |
|  |  | @ 2.00 sqm/cum = 32.54 sqm @ Rs.454.40           | = | Rs. |  |  |     | 14786.18         |            |  |
| Base quantity = 8.88 cum @ 2.00 sqm/cum = 17.76 sqm @ 92.90          |  |  |   |     |  |  |     |                  |            |  |
|  |  |  | = | Rs. |  |  |     | 1649.90          |            |  |
| <b>HYSD reinforcement</b>  |  |  |   |     |  |  |     |                  |            |  |
| Quantity = 25.15 cum   |  |  |   |     |  |  |     |                  |            |  |
|  |  | @ 1 Qtl/ cum = 25.15 Qtl @ Rs. 5520.50           | = | Rs. |  |  |     | 138840.58        |            |  |
| <b>Sand filling</b>  |  |  |   |     |  |  |     |                  |            |  |
|  |  | 2 x 7.4m x 2.4m x 0.15 m = 5.33 cum @ Rs. 495.20 | = | Rs. |  |  |     | 2639.42          |            |  |
| <b>PCC (1:2:4)</b>   |  |  |   |     |  |  |     |                  |            |  |
|  |  | 2 x 7.4 x 2.4 x 0.1m = 3.55 cum @ Rs.5845.70     | = | Rs. |  |  |     | 20752.24         |            |  |
|  |  |  |   |     |  |  |     | <b>324915.57</b> |            |  |
| Add 15% of CW for e/w, back filling & disposal of surplus earth      |  |  |   |     |  |  |     |                  |            |  |
|  |  |  | = | Rs. |  |  |     | 48737.34         |            |  |
|  |  |  |   |     |  |  |     | <b>373652.91</b> |            |  |
| Add for piping 20% of above  |  |  |   |     |  |  |     |                  |            |  |
|  |  |  | = | Rs. |  |  |     | 74730.58         |            |  |
| Add for sludge pump (2 nos.) for discharge 7m <sup>3</sup> of sludge |  |  |   |     |  |  |     |                  |            |  |
|  |  | @ Rs. 50,000/E                                   |   |     |  |  | Rs. | 100000           |            |  |
|  |  |  |   |     |  |  | Rs. | <b>548383.49</b> |            |  |

|                                       |                       |  |      |                  |  |
|---------------------------------------|-----------------------|--|------|------------------|--|
| <b>Walk way 1000m wide all around</b> |                       |  |      |                  |  |
| S/s Hand-railing = 68.00 m            |                       |  |      |                  |  |
|                                       | @Rs. 3392.00          |  | Rs.  | 230656.00        |  |
| Sand filling                          |                       |  |      |                  |  |
|                                       | =5.25 cum @ Rs.495.20 |  | Rs.  | 2599.80          |  |
| PCC (1: 2 : 4 )                       |                       |  |      |                  |  |
|                                       | = 0.35 cum            |  |      |                  |  |
|                                       | @ Rs. 5845.70         |  | Rs.  | 2046.00          |  |
| Chequered tile =                      |                       |  |      |                  |  |
|                                       | 35 sqm @ Rs. 641.10   |  | Rs.  | 22438.50         |  |
|                                       |                       |  | Rs.  | <b>806123.79</b> |  |
|                                       |                       |  | Say, | <b>806100.00</b> |  |

| <b>Anaerobic Baffled Reactors (2 Nos.)</b>                |                             |  |       |           |
|---|-----------------------------|--|-------|-----------|
| RCC M-25  |                             |  |       |           |
| Base Slab   | 2 x 11.28 x 2.40 x 0.25 =   |  | 13.54 | Cum       |
| Long wall   | 2 x 2 x 11.28 x 0.2 x 2.0 = |  | 18.05 | Cum       |
| Short wall  | 2 x 7 x 2.0 x 0.2 x 2.0 =   |  | 11.2  | Cum       |
| Roof slab   | 2 x 11.28 x 2.40 x 0.1 =    |  | 5.41  | Cum       |
| Baffle wall   | 2 x 2.0 x 2.0 x 0.1 =       |  | 0.80  | Cum       |
|   |                             |  | 49.00 | Cum       |
|   | @ Rs.5815.00/cum            |  | Rs.   | 284935.00 |
| <b>Centering &amp; shuttering</b>                         |                             |  |       |           |
| <b>Base slab</b>  |                             |  |       |           |
| Quantity = 13.54 cum                                      |                             |  |       |           |
| C/s @ 13.54 x 2 = 27.08 sqm @Rs.92.90/ sqm                |                             |  | Rs.   | 2515.73   |
| <b>Wall</b>   |                             |  |       |           |
| Quantity = 30.05 cum                                      |                             |  |       |           |
| C/s @ 2.00 sqm/ cum = 60.10 sqm @ Rs.454.40/ sqm          |                             |  | Rs.   | 27309.44  |
| Roof slab   |                             |  |       |           |
| Quantity = 5.41 cum                                       |                             |  |       |           |
| C/s @ 10sqm/ cum = 5.41 x 10= 54.10 sqm @ Rs.352.10 / sqm |                             |  | Rs.   | 19048.61  |
| <b>HYSD reinforcement</b>                                 |                             |  |       |           |
| 49 qtl @ Rs. 5520.50                                      |                             |  | Rs.   | 270504.50 |

|   |  |              |            |                            |
|---|--|--------------|------------|----------------------------|
| <b>Sand filling</b>   |  |              |            |                            |
| 2 x 11.28 x 2.4 x 0.15 = 8.12 cum @ Rs. 495.20/cum                |  |              | Rs.        | 4021.02                    |
| <b>PCC (1:2:4)</b>  |  |              |            |                            |
| 2 x 11.28 x 2.4 x 0.10 = 5.41 cum @Rs.5845.70/cum                 |  |              | Rs.        | 31625.24                   |
|   |  |              | <b>Rs.</b> | <b>639959.54</b>           |
| <b>Add for earth work, back filling &amp; disposal of surplus</b> |  |              |            |                            |
| earth 15% of civil work.  |  |              | Rs.        | 95993.93                   |
|   |  |              | <b>Rs.</b> | <b>735953.47</b>           |
| <b>Add 25% for piping work</b>                                    |  |              | Rs.        | 183988.37                  |
|   |  | <b>Total</b> | <b>Rs.</b> | <b>919941.84</b>           |
|   |  |              |            | <b>Say Rs. 9,19,900.00</b> |

|   |  |               |              |                       |
|---|--|---------------|--------------|-----------------------|
| <b>Planted Gravel Filter (Horizontal)- 1 No.</b>  |  |               |              |                       |
| <b>M-25</b>                                       |  |               |              |                       |
| Foundation - 2 x (25.3m + 20.3m) x 0.3m x 0.15m = |  |               |              | 4.10 cum              |
| Wall - 2 x (25.15 + 20.15) x 1.0m x 0.15m =       |  |               |              | 13.59 cum             |
|   |  |               |              | 17.69 cum             |
|   |  | @ Rs. 5815.00 | Rs.          | 102867.35             |
| <b>Centering &amp; shuttering</b>                 |  |               |              |                       |
| Foundation – 4.10 cum                             |  |               |              |                       |
| Quantity 1.50 sqm/cum = 6.15 sqm                  |  |               |              |                       |
|   |  | @ Rs. 92.90   | Rs.          | 571.34                |
| Wall - 13.59 cum                                  |  |               |              |                       |
| Quantity @ 2.00 sqm/ cum = 27.18 sqm              |  |               |              |                       |
|   |  | @ Rs. 454.40  | Rs.          | 12350.59              |
| <b>HYSD reinforcement</b>                         |  |               |              |                       |
| RCC M25 = 17.69 cum                               |  |               |              |                       |
| Quantity 1qtl/ cum = 17.69 qtl.                   |  | @ Rs.5520.50  | Rs.          | 97657.65              |
| <b>Brick flooring with brick on edge</b>          |  |               |              |                       |
| No. of bricks = 25 x 20 x 0.12 = 60 cum           |  |               |              |                       |
|   |  | @ Rs. 4003.80 | Rs.          | 240228.00             |
| <b>Washed Gravel Bed</b>                          |  |               |              |                       |
| 25 m x 20 m x 0.8 m = 400 cum                     |  | @Rs. 2500     | Rs.          | 1000000.00            |
|   |  |               | <b>Total</b> | <b>Rs. 1453674.93</b> |

|  |  |                          |  |                             |  |            |                   |
|--|--|--------------------------|--|-----------------------------|--|------------|-------------------|
|  |  |                          |  |                             |  |            |                   |
| Add 10% of CW for earth work & disposal of |  |                          |  |                             |  |            |                   |
| surplus earth                              |  |                          |  |                             |  | Rs.        | 145367.49         |
|  |  |                          |  | <b>Total</b>                |  | <b>Rs.</b> | <b>1509942.42</b> |
| Add 25% for plantation & construction of   |  |                          |  |                             |  |            |                   |
| channels.                                  |  |                          |  |                             |  | Rs.        | 363418.73         |
|  |  |                          |  |                             |  | Rs.        | <b>1962461.16</b> |
| <b>RCC collection sump of size 8 cum</b>   |  | <b>@ Rs. 30000 / cum</b> |  |                             |  | Rs.        | 240000.00         |
|  |  |                          |  |                             |  |            |                   |
|  |  |                          |  |                             |  | <b>Rs.</b> | <b>2202461.16</b> |
|  |  |                          |  |                             |  |            |                   |
|  |  |                          |  | <b>Say Rs. 22,02,000.00</b> |  |            |                   |

| <b>Unplanted Drying Beds (6 Nos.)</b>         |   |  |               |   |     |  |           |
|---|---|--|---------------|---|-----|--|-----------|
| <b>M-25</b>                                   |   |  |               |   |     |  |           |
| Footing                                       | = | 6 x 2 x (15.6 + 4.6) x 0.6 x 0.2 =       |               |   |     |  |           |
|   |   | 29.09 cum                                |               |   |     |  |           |
| Wall  | = | 6 x 2 x (15.2+4.2) x 0.95 x 0.2          |               |   |     |  |           |
|   |   | = 44.23 cum                              |               |   |     |  |           |
|   |   | 73.32 cum                                | @ Rs. 5815.00 | = | Rs. |  | 426355.80 |
| C/S @ 2.00 sqm / cum = 88.46 sqm @ Rs. 454.40 |   |  |               | = | Rs. |  | 40196.22  |
| Footing                                       | = | 43.64 sqm @ Rs. 92.90 / sqm              |               | = | Rs. |  | 4054.16   |
| <b>HYSD reinforcement</b>                     |   |  |               |   |     |  |           |
|   |   | 73.32 qtl @ Rs. 5520.50                  |               | = | Rs. |  | 404763.06 |
| <b>Sand filling</b>                           |   |  |               |   |     |  |           |
|   |   | 6 x 15m x 4m x 0.15 m = 54 cum           |               |   |     |  |           |
|   |   | @ Rs. 495.20                             |               | = | Rs. |  | 26740.80  |
| <b>Gravel Bed</b>                             |   |  |               |   |     |  |           |
|   |   | 6 x 15m x 4m x 0.3m =108 cum @           |               |   |     |  |           |
|   |   | Rs.2000/cum                              |               | = | Rs. |  | 216000.00 |
| <b>PCC 1:2:4 below footing</b>                |   |  |               |   |     |  |           |
|   |   | 6 x 2 x (15.6 + 4.6) x 0.6 x 0.1         |               | = |     |  |           |
|   |   | = 14.54 cum @ Rs. 5845.70 / cum          |               |   | Rs. |  | 84996.48  |
| <b>Sand filling</b>                           |   | 6 x 2 x (15.6 + 4.6) x 0.6 x 0.15        |               |   |     |  |           |
|   |   | = 21.82 cum @ 495.20 / cum               |               | = | Rs. |  | 10805.26  |
| <b>Fly ash brick on edge.</b>                 |   |  |               |   |     |  |           |
|   |   | 6 x 15m x 4 x 0.12m = 43.2 cum @ 4003.80 |               | = | Rs. |  | 172964.16 |



|    |   |     |  |                            |
|----|---|-----|--|----------------------------|
| 5  | One production well with OHT of 5000 ltr. capacity  |     |  |                            |
|    | Production well with s/s pump set   | Rs  |  | 300,000.00                 |
|    | OHT of 5000 ltr. capacity with piping work @ Rs. 7/1ltr.  | Rs. |  | 35,000.00                  |
|    | Staging for OHT   | Rs. |  | 15000.00                   |
| 6  | Electrical sub-station 25 KVA   | Rs. |  | 500000.00                  |
| 7  | Yard lighting   | Rs. |  | 250000.00                  |
| 8  | Internal road (3.5 m width)   |     |  |                            |
|    | 1000 mtr. @ Rs. 4766.50   | Rs. |  | 4766500.00                 |
| 9  | Protection wall around the SeTP site- 382mtr.   | Rs. |  | 2065400.00                 |
| 10 | Pump house for leachate, sludge and effluent<br>Plinth area = 15.75 m <sup>2</sup> @ 17000.00/sqm | Rs. |  | 267750.00                  |
| 11 | Add 10% for int EI  | Rs. |  | 26775.00                   |
| 12 | Site Development, plantation & landscaping,<br>lab equipment etc.                                 | Rs. |  | 1500000.00                 |
|    |   | Rs. |  | <b>12587639.00</b>         |
|    |   |     |  | <b>Say, 1,25,88,000.00</b> |

| <b>Anaerobic filters (2 chambers)</b>       |                        |             |            |                    |
|---|------------------------|-------------|------------|--------------------|
| Footing                                     | 2.98 cum               |             |            |                    |
| Wall  | 5.44 cum               |             |            |                    |
| Roof  | 0.62 cum               |             |            |                    |
| Total:                                      | 9.04 cum @ 5815.00/cum |             | Rs.        | 52567.60           |
| Centering & Shuttering                      |                        |             |            |                    |
| footing                                     | 4.47 sqm @ 92.90       |             | Rs.        | 415.26             |
| Wall  | 10.88 sqm @ 454.40     |             | Rs.        | 4943.87            |
| Roof  | 6.20 sqm @ 352.10      |             | Rs.        | 2183.02            |
| HYSD Bars for 9.04 cum                      | 9.04 qtl @ 5520.50     |             | Rs.        | 49905.32           |
| Sand filling                                | 2.23 cum @ 495.20      |             | Rs.        | 1104.30            |
| PCC below footing                           | 1.49 cum @ 5845.70     |             | Rs.        | 8710.09            |
|   |                        |             | Rs.        | 119829.46          |
| 15% back filling and surplus earth disposal |                        |             | Rs.        | 17974.42           |
| Add 25% for piping                          |                        |             | Rs.        | 34450.97           |
| Add cost of plastic media                   |                        |             | Rs.        | 20000.00           |
|   |                        | Total:      | Rs.        | 192254.85          |
|   |                        | <b>Say,</b> | <b>Rs.</b> | <b>1,92,300.00</b> |



**SAMBALPUR  
ANALYSIS (2015-16)**

| Sl. No. | Description of items.   | Qty.  |     | Unit | Rate    | Amount  | Remarks    |
|---------|---|-------|-----|------|---------|---------|------------|
|         |   |       |     |      | in Rs.  | in Rs.  |            |
| 1       | Earth work in ordinary soil within 50m initial lead & 1.5m initial lift including dressing and levelling of the foundation trenches etc. all complete as per direction of Er-in - charge. |       |     |      |         |         |            |
|         | Per 100cum  |       |     |      |         |         |            |
|         | Man mulia   | 16.00 | Nos | Each | 200.00  | 3200.00 |            |
|         | Female mulia  | 16.00 | Nos | Each | 200.00  | 3200.00 |            |
|         |   |       |     |      | A       | 6400.00 |            |
|         | O.H.C. 7.5% on (A)  |       |     |      |         | 480.00  |            |
|         | CP. 7.5% on (A)   |       |     |      |         | 480.00  |            |
|         |   |       |     |      | Total   | 7360.00 |            |
|         | add for dressing and leveling   | 20%   |     |      |         | 1472.00 |            |
|         |   |       |     |      | Total   | 8832.00 | Per 100cum |
|         |   |       |     |      | Cess-1% | 88.32   |            |
|         |   |       |     |      |         | 8920.32 | Per 100cum |
|         |   |       |     |      |         | 89.20   | per cum    |
| 2       | Earth work in hard soil within 50m initial lead & 1.5m initial lift including dressing and levelling of the foundation trenches etc. all complete as per direction of Er-in - charge.     |       |     |      |         |         |            |
|         | Per 100cum  |       |     |      |         |         |            |



|          |   |                   |     |                     |         |          |               |
|----------|---|-------------------|-----|---------------------|---------|----------|---------------|
| <b>5</b> | Earth work in excavation in foundation        |                   |     |                     |         |          |               |
|          | in all kind of soil                           |                   |     |                     |         |          |               |
|          | a) Earth work in all kinds of soil per 100cum |                   |     |                     |         | 9123.33  |               |
|          | b) Add for levelling & dressing               |                   |     |                     | 20%     | 1824.67  |               |
|          |   |                   |     |                     |         | 10948.00 |               |
|          |   |                   |     |                     | Cess-1% | 109.48   |               |
|          |   |                   |     |                     |         | 11057.48 | per<br>100cum |
| <b>6</b> | Filling in foundation & plinth with excavated |                   |     |                     |         |          |               |
|          | materials including watering & ramming as     |                   |     |                     |         |          |               |
|          | directed by the Er-in charge.                 |                   |     |                     |         |          |               |
|          |   | Rate of earth     |     |                     | A       | 9123.33  |               |
|          |   | work              |     |                     |         |          |               |
|          |   | 2/3rd rate of (A) |     |                     |         | 6082.22  |               |
|          |   |                   |     |                     | Total   | 6082.22  | Per<br>100cum |
|          |   |                   |     |                     | Cess-1% | 60.82    |               |
|          |   |                   |     |                     |         | 6143.04  | Per<br>100cum |
|          |   |                   |     |                     |         | 61.43    | Per cum       |
| <b>7</b> | Suppling all materials, labour and T&P for    |                   |     |                     |         |          |               |
|          | Filling in foundation & plinth with sand      |                   |     |                     |         |          |               |
|          | watered                                       |                   |     |                     |         |          |               |
|          | & rammed etc. all complete.                   |                   |     |                     |         |          |               |
|          | Per 100cum                                    |                   |     |                     |         |          |               |
|          | Man mulia                                     | 12.36             | Nos | Each                | 200.00  | 2472.00  |               |
|          | O.H.C. 7.5% on (A)                            |                   |     |                     |         | 185.40   |               |
|          | CP-7.5% on (A)                                |                   |     |                     |         | 185.40   |               |
|          |   |                   |     | Total               |         | 2842.80  | Per<br>100cum |
|          |   |                   |     | <b>Per<br/>1cum</b> |         | 28.43    |               |
|          | Cost of sand filling                          | 1.00              | cum | cum                 | 48.00   | 48.00    |               |
|          | Carriage of sand                              | 1.00              | cum | cum                 | 413.84  | 413.84   |               |
|          |   |                   |     | Total               |         | 490.27   | Per cum       |
|          |   |                   |     |                     | Cess-1% | 4.90     |               |
|          |   |                   |     |                     | Total   | 495.17   | Per cum       |
|          |   |                   |     |                     | Say,    | 495.20   | Per cum       |

|   |  |      |      |      |               |                |         |
|---|--|------|------|------|---------------|----------------|---------|
| 8 | Cement concrete (1:3:6) with 4cm size crusher                                      |      |      |      |               |                |         |
|   | broken hard granite metal including cost, conveyance, royalties etc. all complete. |      |      |      |               |                |         |
|   | <u>Material</u>  |      |      |      |               |                |         |
|   | Metal (4cm size)   | 0.96 | cum  | cum  | 780.00        | 748.80         |         |
|   | Sand for filling   | 0.48 | cum  | cum  | 55.00         | 26.40          |         |
|   | Cement   | 2.29 | Qntl | Qntl | 714.00        | 1635.06        |         |
|   | <u>Labours</u>   |      |      |      |               | <b>2410.26</b> |         |
|   | Mason 2nd class  | 0.18 | Nos  | Each | 240.00        | 43.20          |         |
|   | Man mulia  | 2.50 | Nos  | Each | 200.00        | 500.00         |         |
|   | Female mulia   | 1.40 | Nos  | Each | 200.00        | 280.00         |         |
|   |  |      |      |      | <b>823.20</b> |                |         |
|   | O.H.C. 7.5% on (A)   |      |      |      |               | 242.51         |         |
|   | CP-7.5%  |      |      |      |               | 242.51         |         |
|   |  |      |      |      |               | <b>3718.48</b> |         |
|   | <u>Carriage &amp; royalties</u>  |      |      |      |               |                |         |
|   | Metal  | 0.96 | cum  | cum  | 402.38        | 386.28         |         |
|   | Sand for mortar  | 0.48 | cum  | cum  | 524.24        | 251.64         |         |
|   | Cement   | 2.29 | Qntl | Qntl | 16.90         | 38.70          |         |
|   |  |      |      |      | Total         | 4395.10        | Per cum |
|   |  |      |      |      | Cess-1%       | 43.95          |         |
|   |  |      |      |      | Total         | 4439.05        | Per cum |
|   |  |      |      |      | Say,          | 4439.10        |         |
| 9 | Cement concrete (1:4:8) with 4cm size crusher                                      |      |      |      |               |                |         |
|   | broken hard granite metal including cost, conveyance, royalties etc. all complete. |      |      |      |               |                |         |
|   | <u>Material</u>  |      |      |      |               |                |         |
|   | Metal (4cm size)   | 0.96 | cum  | cum  | 720.00        | 691.20         |         |
|   | Sand   | 0.48 | cum  | cum  | 47.00         | 22.56          |         |
|   | Cement   | 1.72 | Qntl | Qntl | 714.00        | 1228.08        |         |
|   | <u>Labours</u>   |      |      |      |               |                |         |

|           |  |      |      |      |         |         |         |
|-----------|--|------|------|------|---------|---------|---------|
|           | Mason 2nd class  | 0.18 | Nos  | Each | 240.00  | 43.20   |         |
|           | Man mulia  | 2.50 | Nos  | Each | 200.00  | 500.00  |         |
|           | Female mulia   | 1.40 | Nos  | Each | 200.00  | 280.00  |         |
|           |  |      |      |      | A       | 2765.04 |         |
|           | O.H.C. 7.5% on (A)   |      |      |      |         | 207.38  |         |
|           | CP 7.5% on (A)   |      |      |      |         | 207.38  |         |
|           |  |      |      |      | B       | 3179.80 |         |
|           | <u>Carriage &amp; royalties</u>  |      |      |      |         |         |         |
|           | Metal  | 0.96 | cum  | cum  | 347.20  | 333.31  |         |
|           | Sand for mortar  | 0.48 | cum  | cum  | 183.84  | 88.24   |         |
|           | Cement   | 1.72 | Qntl | Qntl | 16.90   | 29.07   |         |
|           |  |      |      |      | Total   | 3630.42 | Per cum |
|           |  |      |      |      | Cess-1% | 36.30   |         |
|           |  |      |      |      |         | 3666.72 | Per cum |
|           |  |      |      |      |         |         |         |
| <b>10</b> | Cement concrete (1:2:4) with 12cm size crusher                                     |      |      |      |         |         |         |
|           | broken hard granite chips including cost, conveyance, royalties etc. all complete. |      |      |      |         |         |         |
|           | <u>Material</u>  |      |      |      |         |         |         |
|           | Chips (12mm size)  | 0.90 | cum  | cum  | 1151.00 | 1035.90 |         |
|           | Sand for mortar  | 0.45 | cum  | cum  | 52.00   | 23.40   |         |
|           | Cement   | 3.23 | Qntl | Qntl | 714.00  | 2306.22 |         |
|           | <u>Labours</u>   |      |      |      |         |         |         |
|           | Mason 2nd class  | 0.68 | Nos  | Each | 240.00  | 163.20  |         |
|           | Man mulia  | 3.20 | Nos  | Each | 200.00  | 640.00  |         |
|           | Female mulia   | 1.40 | Nos  | Each | 200.00  | 280.00  |         |
|           |  |      |      |      | A       | 4448.72 |         |
|           | O.H.C. 7.5% on (A)   |      |      |      |         | 333.65  |         |
|           | CP 7.5% on (A)   |      |      |      |         | 333.65  |         |
|           |  |      |      |      | B       | 5116.03 |         |



|           |  |                 |     |      |              |          |          |
|-----------|--|-----------------|-----|------|--------------|----------|----------|
| <b>12</b> | Suppling, fitting & placing uncoated HYSD bar reinforcement complete as per drawing and technical specification including cost, conveyance of all materials etc. all complete. |                 |     |      |              |          |          |
|           | Unit-1MT   |                 |     |      |              |          |          |
|           | Taking Output-1MT  |                 |     |      |              |          |          |
|           | <u>Material</u>  |                 |     |      |              |          |          |
|           | HYSD bars including 5% overlaps & wastage.   | 1.05            | MT  | MT   | 42173.00     | 44281.65 |          |
|           | Binding wires  | 8               | kg  | kg   | 77.00        | 616.00   |          |
|           | <u>Labours</u>   |                 |     |      |              |          |          |
|           | Mate   | 0.44            | Nos | Each | 220.00       | 96.80    |          |
|           | Blacksmith(special)  | 3.00            | Nos | Each | 260.00       | 780.00   |          |
|           | Man mulia  | 8.00            | Nos | Each | 200.00       | 1600.00  |          |
|           |  |                 |     |      | A            | 47374.45 |          |
|           | O.H.C. 7.5% on(A)  |                 |     |      |              | 3553.08  |          |
|           | CP. 7.5% on(A)   |                 |     |      |              | 3553.08  |          |
|           | Carriage & Royalty   | 1.05            | mt  |      | 169          | 177.45   |          |
|           |  |                 |     |      | B            | 54658.07 | Per MT   |
|           |  | Rate per 1qntl. |     |      | Total        | 5465.81  | Per qntl |
|           |  | Cess 1%         |     |      |              | 54.66    |          |
|           |  |                 |     |      |              | 5520.47  |          |
|           |  |                 |     |      | Rate per qtl | 5520.50  |          |
| <b>13</b> | Rigid & smooth centering & shuttering for R.C.C. works including false work & dismantling them after casting including cost of materials complete in ground floor              |                 |     |      |              |          |          |
|           |  |                 |     |      |              |          |          |

|  |                              |               |      |          |          |          |
|--|------------------------------|---------------|------|----------|----------|----------|
| <b>i)Roof slab, landing &amp; chajjas up to 4.3m height.</b>                   |                              |               |      |          |          |          |
| Details for 9sqm.  |                              |               |      |          |          |          |
| Non sal wood scantling   | 0.112                        | cum           | cum  | 19788.00 | 2216.26  |          |
| Planks 38mm  | 0.34                         | cum           | cum  | 19788.00 | 6727.92  |          |
| 120mmdia bullah  | 56.00                        | mtr           | mtr  | 101.00   | 5656.00  |          |
| carriage of wood   | 1.142                        | 1.25          | cum  | 135.20   | 154.40   |          |
|  |                              | cum           |      | A        | 14754.58 |          |
| Considering 10 times use of the materials for use once                         |                              | 1/10th of (A) |      | B        | 1475.46  |          |
| Carpenter 2nd class  | 2.75                         | Nos           | Each | 240.00   | 660.00   |          |
| Semiskilled mulia  | 2.75                         | Nos           | Each | 220.00   | 605.00   |          |
|  |                              |               |      | C        | 2740.46  |          |
| O.H.C. 7.5% on (C)   |                              |               |      |          | 205.53   |          |
| CP. 7.5% on (C)  |                              |               |      |          | 205.53   |          |
|  |                              |               |      | D        | 3151.53  |          |
|  | Rate per 1sqm.               |               |      | E        | 350.17   | Per sqm. |
|  |                              |               |      | Cess-1%  | 3.50     |          |
|  |                              |               |      |          | 353.67   | Per sqm. |
|  | For 1st floor add extra 20%  |               |      |          | 70.03    |          |
|  | <b>For 1st floor</b>         |               |      | F        | 423.71   | Per sqm. |
|  | For 1st floor add extra 20%  |               |      |          | 84.74    |          |
|  | <b>For 2nd floor</b>         |               |      | G        | 508.45   | Per sqm. |
|  | <b>Average rate=(E+F+G)=</b> |               |      |          | 427.44   | Per sqm. |
| <b>ii)R.C.C. foundation &amp; plinth band, footings, bases of columns etc.</b> |                              |               |      |          |          |          |
| Details for 10sqm.   |                              |               |      |          |          |          |



|  |  |                |               |      |                |         |          |
|--|--|----------------|---------------|------|----------------|---------|----------|
|  | 25mm thick non sal planks                              | 0.267          | cum           | cum  | 19788          | 5283.40 |          |
|  | Non sal bullah 80mmdia for strusting                   | 12.6           | mtr           | mtr  | 48             | 604.80  |          |
|  | carriage of wood                                       | 0.3284         | cum           | cum  | 135.2          | 44.40   |          |
|  |  |                |               |      | A              | 5932.60 |          |
|  | Considering 10 times use of the materials for use once |                | 1/10th of (A) |      | B              | 593.26  |          |
|  | Carpenter 2nd class                                    | 0.50           | Nos           | Each | 240.00         | 120.00  |          |
|  | Semiskilled mulia                                      | 0.50           | Nos           | Each | 220.00         | 110.00  |          |
|  |  |                |               |      | C              | 823.26  |          |
|  | O.H.C. 7.5% on ( C )                                   |                |               |      |                | 61.74   |          |
|  | Cp. 7.5% on ( C )                                      |                |               |      |                | 61.74   |          |
|  |  |                |               |      | D              | 946.75  |          |
|  |  | Rate per 1sqm. |               |      |                | 94.67   | Per sqm. |
|  |  |                |               |      | Cess-%         | 0.95    |          |
|  |  |                |               |      |                | 95.62   |          |
|  |  |                |               |      |                |         |          |
|  | <b>iii)R.C.C. beams &amp; columns.</b>                 |                |               |      |                |         |          |
|  | <u>Details for 4.2sqm.</u>                             |                |               |      |                |         |          |
|  | 38mm thick non sal planks                              | 0.218          | cum           | cum  | 19788.00       | 4313.78 |          |
|  | 120mmdia bullah  | 15.2           | mtr           | mtr  | 76.00          | 1155.20 |          |
|  | Sal bullah 80mmdia for bracing                         | 8              | mtr           | mtr  | 76.00          | 608.00  |          |
|  | carriage of wood                                       | 0.456          | cum           | cum  | 80.00          | 36.48   |          |
|  |  |                |               |      | A              | 6113.46 |          |
|  | Considering 10 times use of the materials for use once |                | 1/10th of (A) |      | B              | 611.35  |          |
|  | Carpenter 2nd class                                    | 2.75           | Nos           | Each | 240.00         | 660.00  |          |
|  | Semiskilled mulia                                      | 2.75           | Nos           | Each | 220.00         | 605.00  |          |
|  |  |                |               |      | C              | 1876.35 |          |
|  | O.H.C. 7.5% on (C)                                     |                |               |      |                | 140.73  |          |
|  | Contractors profit@7.5%                                |                |               |      |                | 140.73  |          |
|  |  |                |               |      | D              | 2157.80 |          |
|  |  | Rate per 1sqm. |               |      | E              | 513.76  | Per sqm. |
|  |  |                |               |      | <u>Cess@1%</u> | 5.14    |          |
|  |  |                |               |      | -              | 518.90  | Per sqm. |

|           |  |                              |               |      |                         |         |          |
|-----------|--|------------------------------|---------------|------|-------------------------|---------|----------|
|           |  |                              |               |      |                         |         |          |
|           |  | For 1st floor add extra 20%  |               |      |                         | 102.75  |          |
|           |  | <b>For 1st floor</b>         |               |      | F                       | 1140.55 | Per sqm. |
|           |  | For 1st floor add extra 20%  |               |      |                         | 228.11  |          |
|           |  | <b>For 2nd floor</b>         |               |      | G                       | 1368.66 |          |
|           |  | <b>Average rate=(E+F+G)=</b> |               |      |                         | 1007.66 | Per sqm. |
|           | <b>iii)R.C.C. lintels.</b>   |                              |               |      |                         |         |          |
|           | <u>Details for 7.8sqm.</u>   |                              |               |      |                         |         |          |
|           | 38mm thick non sal planks  | 0.413                        | cum           | cum  | 19788.00                | 8172.44 |          |
|           | 120mmdia non sal bullah  | 21                           | mtr           | mtr  | 56.00                   | 1176.00 |          |
|           | carriage of wood   | 0.689                        | cum           | cum  | 80.00                   | 55.12   |          |
|           |  |                              |               |      | A                       | 9403.56 |          |
|           | Considering 10 times use of the materials for use once   |                              | 1/10th of (A) |      | B                       | 940.36  |          |
|           | Carpenter 2nd class  | 1.25                         | Nos           | Each | 240.00                  | 300.00  |          |
|           | Semiskilled mulia  | 1.25                         | Nos           | Each | 220.00                  | 275.00  |          |
|           |  |                              |               |      | C                       | 1515.36 |          |
|           | O.H.C. 7.5% on ( C )   |                              |               |      |                         | 113.65  |          |
|           | <a href="#">CP@1.5%</a>  |                              |               |      |                         | 113.65  |          |
|           |  |                              |               |      | D                       | 1742.66 |          |
|           |  |                              |               |      | <a href="#">Cess@1%</a> | 17.43   |          |
|           |  |                              |               |      |                         | 1760.09 |          |
|           |  | Rate per 1sqm.               |               |      |                         | 225.65  | Per sqm. |
|           |  |                              |               |      |                         |         |          |
| <b>14</b> | Fly Ash bricks masonry in CM (1:6) using fly ash   |                              |               |      |                         |         |          |
|           | brick of size 25cmx12cmx8cm including cost conveyance, royalties of all materials etc. all complete. |                              |               |      |                         |         |          |
|           | <u>Labours</u>   |                              |               |      |                         |         |          |
|           | Mason special  | 0.35                         | Nos           | Each | 260.00                  | 91.00   |          |
|           | Mason 2nd class  | 1.05                         | Nos           | Each | 240.00                  | 252.00  |          |

|           |   |       |      |      |         |                |         |
|-----------|---|-------|------|------|---------|----------------|---------|
|           | Man mulia   | 1.41  | Nos  | Each | 200.00  | 282.00         |         |
|           | Female mulia  | 1.41  | Nos  | Each | 200.00  | 282.00         |         |
|           | Preparing mortar & getting water etc.   | 0.14  | Nos  | Each | 200.00  | 28.00          |         |
|           |   |       |      |      |         | <b>935.00</b>  |         |
|           | <u>Material</u>   |       |      |      |         |                |         |
|           | fly ash Bricks (25cmx12cmx8cm size)   | 350   | Nos  | 1000 | 4750.00 | 1662.50        |         |
|           |   |       |      | Nos  |         |                |         |
|           | Sand (screened & washed)  | 0.28  | cum  | cum  | 55.00   | 15.40          |         |
|           | Cement  | 0.672 | qntl | qntl | 714.00  | 479.81         |         |
|           |   |       |      |      |         | <b>2157.71</b> |         |
|           | O.H.C. @ 7.5% + CP @ 7.5%   |       |      |      |         | <b>463.91</b>  |         |
|           |   |       |      |      |         |                |         |
|           | <u>Carriage &amp; royalties</u>   |       |      |      |         |                |         |
|           | Fly ash Bricks (25cmx12cmx8cm size)   | 350   | Nos  | 1000 | 712.40  | 249.34         |         |
|           |   |       |      | Nos  |         |                |         |
|           | Sand for mortar   | 0.28  | cum  | cum  | 524.24  | 146.79         |         |
|           | Cement  | 0.672 | qntl | qntl | 16.90   | 11.36          |         |
|           |   |       |      |      |         | 3964.11        |         |
|           |   |       |      |      | Cess-1% | 39.64          |         |
|           |   |       |      |      |         | 4003.75        | Per cum |
|           |   |       |      |      | Say,    | 4003.80        | Per cum |
| <b>15</b> | Fly ash brick masonry in CM (1:6) using fly ash   |       |      |      |         |                |         |
|           | brick of size 25cmx12cmx8cm including cost  |       |      |      |         |                |         |
|           | conveyance, royalties of all materials etc. all   |       |      |      |         |                |         |
|           | complete.   |       |      |      |         |                |         |
|           |   |       |      |      |         | 3859.77        |         |
|           |   |       |      |      |         | 33.00          |         |
|           |   |       |      |      | Total   | 3892.77        | Per cum |
| <b>15</b> | Brick works with K.B. bricks having crushing strength between 100kg/sq.cm to 149kgsq.cm in C.M. (1:8) in foundation & plinth including cost, conveyance, royalties of all materials etc. all complete |       |      |      |         |                |         |

|           |  |                         |      |      |         |          |         |
|-----------|--|-------------------------|------|------|---------|----------|---------|
|           | <u>Labours</u>   |                         |      |      |         |          |         |
|           | Mason special  | 0.35                    | Nos  | Each | 260.00  | 91.00    |         |
|           | Mason 2nd class  | 1.05                    | Nos  | Each | 240.00  | 252.00   |         |
|           | Man mulia  | 1.41                    | Nos  | Each | 200.00  | 282.00   |         |
|           | Female mulia   | 1.41                    | Nos  | Each | 200.00  | 282.00   |         |
|           | Preparing mortar & getting water etc.  | 0.14                    | Nos  | Each | 200.00  | 28.00    |         |
|           | <u>Material</u>  |                         |      |      |         |          |         |
|           | K.B. Bricks (25cmx12cmx8cm size)   | 350                     | Nos  | 1000 | 5692.00 | 1992.20  |         |
|           |  |                         |      | Nos  |         |          |         |
|           | Sand (screened & washed)   | 0.28                    | cum  | cum  | 51.00   | 14.28    |         |
|           | Cement   | 0.501                   | qntl | qntl | 651.60  | 326.45   |         |
|           |  |                         |      |      | A       | 3267.93  |         |
|           | O.H.C. 10% on (A)  |                         |      |      |         | 326.7932 |         |
|           |  |                         |      |      | B       | 3594.72  |         |
|           | <u>Carriage &amp; royalties</u>  |                         |      |      |         |          |         |
|           | K.B. Bricks (25cmx12cmx8cm size)   | 350                     | Nos  | 1000 | 687.30  | 240.56   |         |
|           |  |                         |      | Nos  |         |          |         |
|           | Sand for mortar  | 0.28                    | cum  | cum  | 183.84  | 51.48    |         |
|           | Cement   | 0.501                   | qntl | qntl | 16.90   | 8.47     |         |
|           |  |                         |      |      | Total   | 3895.22  | Per cum |
| <b>16</b> | Brick works with K.B. bricks having crushing strength between 100kg/sq.cm to 149kgsq.cm in C.M. (1:8) in super structure including cost, conveyance, royalties of all materials etc. all complete. |                         |      |      |         |          |         |
|           |  | Rate of F&P.per cum.    |      |      |         | 3895.22  |         |
|           |  | Add for super structure |      |      |         | 33.00    |         |
|           |  |                         |      |      | Total   | 3928.22  | Per cum |
|           |  |                         |      |      | cess-1% | 38.93    |         |

|           |   |        |       |       |         |         |          |
|-----------|---|--------|-------|-------|---------|---------|----------|
|           |   |        |       |       |         | 3928.22 | Per cum  |
| <b>16</b> | 12mm thick cement plaster (1:6) over brick    |        |       |       |         |         |          |
|           | work including cost, conveyance, royalties of |        |       |       |         |         |          |
|           | all materials etc. complete.                  |        |       |       |         |         |          |
|           | <u>Material</u>                               |        |       |       |         |         |          |
|           | Sand for mortar                               | 0.015  | cum   | cum   | 52.00   | 0.78    |          |
|           | Cement  | 0.0358 | Qntl  | Qntl  | 714.00  | 25.56   |          |
|           | <u>Labours</u>                                |        |       |       |         |         |          |
|           | Mason 2nd class                               | 0.14   | Nos   | Each  | 240.00  | 33.60   |          |
|           | Man mulia                                     | 0.07   | Nos   | Each  | 200.00  | 14.00   |          |
|           | Female mulia                                  | 0.05   | Nos   | Each  | 200.00  | 10.00   |          |
|           |   |        |       |       | A       | 83.94   |          |
|           | O.H.C. 7.5% on (A)                            |        |       |       |         | 6.30    |          |
|           | CP. 7.5% on (A)                               |        |       |       |         | 6.30    |          |
|           |   |        |       |       | B       | 96.53   |          |
|           | <u>Carriage &amp; royalties</u>               |        |       |       |         |         |          |
|           | Sand for mortar                               | 0.015  | cum   | cum   | 183.84  | 2.76    |          |
|           | Cement  | 0.0358 | Qntl  | Qntl  | 16.90   | 0.61    |          |
|           |   |        |       |       | Total   | 99.90   | Per sqm. |
|           |   |        |       |       | cess-1% | 1.00    |          |
|           |   |        |       |       |         | 100.89  | Per sqm. |
| <b>17</b> | Cement washing two coats including cost,      |        |       |       |         |         |          |
|           | conveyance, royalties, etc. all complete.     |        |       |       |         |         |          |
|           | Data for 93 sqm                               |        |       |       |         |         |          |
|           | <u>Material</u>                               |        |       |       |         |         |          |
|           | Cement  | 1.5015 | qntl. | qntl. | 714.00  | 1072.07 |          |
|           | <u>Labours</u>                                |        |       |       |         |         |          |
|           | Painter (2nd class)                           | 1      | Nos   | Each  | 240.00  | 240.00  |          |
|           | Man mulia                                     | 1.63   | Nos   | Each  | 200.00  | 326.00  |          |
|           |   |        |       |       | A       | 1638.07 |          |
|           | O.H.C. 7.5% on (A)                            |        |       |       |         | 122.86  |          |
|           | CP. 7.5% on (A)                               |        |       |       |         | 122.86  |          |

|           |  |        |       |                |         |         |          |
|-----------|--|--------|-------|----------------|---------|---------|----------|
|           |  |        |       |                | B       | 1883.78 |          |
|           | Carriage of cement                               | 1.5015 | qntl. | qntl.          | 16.90   | 25.38   |          |
|           |  |        |       |                |         | 1909.16 |          |
|           |  |        |       | Rate for 1sqm. |         | 20.53   | Per sqm. |
|           |  |        |       |                | cess-1% | 0.21    |          |
|           |  |        |       |                |         | 20.73   | Per sqm. |
| <b>18</b> | Finishing walls with water proofing cement paint |        |       |                |         |         |          |
|           | of approved shade on new work two coats to give  |        |       |                |         |         |          |
|           | an even shade including cost of paint.           |        |       |                |         |         |          |
|           | Data for 10 sqm                                  |        |       |                |         |         |          |
|           | <u>Labours</u>                                   |        |       |                |         |         |          |
|           | Painter or polisher(special)                     | 0.22   | Nos   | Each           | 260.00  | 57.20   |          |
|           | Man mulia  | 0.32   | Nos   | Each           | 200.00  | 64.00   |          |
|           |  |        |       |                | A       | 121.20  |          |
|           | O.H.C. 7.5% on (A)                               |        |       |                |         | 9.09    |          |
|           | CP. 7.5% on (A)                                  |        |       |                |         | 9.09    |          |
|           |  |        |       |                | B       | 139.38  |          |
|           | Cost of cement paint                             | 2.5    | kg    | kg             | 46.00   | 115.00  |          |
|           |  |        |       |                | Total   | 254.38  |          |
|           |  |        |       | Rate for 1sqm. |         | 25.44   | Per sqm. |
|           |  |        |       |                | cess-1% | 0.25    |          |
|           |  |        |       |                | Total   | 25.69   | Per sqm. |
| <b>19</b> | Priming 1 coat with any approved primer          |        |       |                |         |         |          |
|           | including cost of all labours and materials etc. |        |       |                |         |         |          |
|           | all complete.                                    |        |       |                |         |         |          |
|           | Data for 9.3 sqm                                 |        |       |                |         |         |          |
|           | <u>Labours</u>                                   |        |       |                |         |         |          |
|           | Painter (special)                                | 0.5    | Nos   | Each           | 260.00  | 130.00  |          |



|           |   |       |     |                |              |                 |          |
|-----------|---|-------|-----|----------------|--------------|-----------------|----------|
| <b>20</b> | Painting 2 coats with any approved paint on new iron work |       |     |                |              |                 |          |
|           | including cost of all labours and materials etc.          |       |     |                |              |                 |          |
|           | all complete.   |       |     |                |              |                 |          |
|           | Data for 9.3 sqm  |       |     |                |              |                 |          |
|           | <u>Labours</u>  |       |     |                |              |                 |          |
|           | Painter (special)   | 1.25  | Nos | Each           | 260.00       | 325.00          |          |
|           | Man mulia   | 1.10  | Nos | Each           | 200.00       | 220.00          |          |
|           |   |       |     |                | A            | 545.00          |          |
|           | O.H.C. 7.5% on (A)  |       |     |                |              | 40.875          |          |
|           | CP. 7.5% on (A)   |       |     |                |              | 40.88           |          |
|           |   |       |     |                | B            | 626.75          |          |
|           |   |       |     | Rate for 1sqm. |              | 67.39           |          |
|           | Cost of paint   | 0.125 | kg  | kg             | 190.00       | 23.88           |          |
|           |   |       |     | Rate for 1sqm. |              | 91.27           | Per sqm. |
|           |   |       |     |                | cess-1%      | 0.91            |          |
|           |   |       |     |                |              | 92.17           | Per sqm. |
| <b>21</b> | <b><u>M-25</u></b>  |       |     |                |              |                 |          |
|           | <b>Data for 15 cum</b>                                    |       |     |                |              |                 |          |
|           |   |       |     |                |              |                 |          |
|           | <b>a) <u>Material</u></b>                                 |       |     |                |              |                 |          |
|           | 20mm Chips  | 8.10  | cum | cum            | 1139.00      | 9225.90         |          |
|           | 10mm Chips  | 5.40  | cum | cum            | 1215.00      | 6561.00         |          |
|           | Coarse Sand   | 6.75  | cum | cum            | 55.00        | 371.25          |          |
|           | Cement  | 6.05  | MT  | MT             | 7140.00      | 43197.00        |          |
|           |   |       |     |                | <b>Total</b> | <b>59355.15</b> |          |
|           |   |       |     |                |              |                 |          |



|           |  |                |      |      |                         |                 |
|-----------|--|----------------|------|------|-------------------------|-----------------|
| <b>b)</b> | <b>Labour</b>                                |                |      |      |                         |                 |
|           | Mate   | 0.86           | Nos. | Nos. | 220.00                  | 189.20          |
|           | Mason Second Class                           | 1.50           | Nos. | Nos. | 240.00                  | 360.00          |
|           | Man Mulia                                    | 20.00          | Nos. | Nos. | 200.00                  | 4000.00         |
|           |  |                |      |      | Total                   | 4549.20         |
| <b>C)</b> | <b>Machinery</b>                             |                |      |      |                         |                 |
|           | Concrete mixture (cap0.40/0.28 cum)          | 6.00           | hour | hour | 177.00                  | 1062.00         |
|           | Generator 33 KVA                             | 6.00           | hour | hour | 240.00                  | 1440.00         |
|           |  |                |      |      | <b>Total</b>            | <b>2502.00</b>  |
|           | Total  | <b>(a+b+c)</b> |      |      |                         | <b>65964.90</b> |
|           | Overhead charges on 15 % (a+b+c) =           |                |      |      |                         | 9960.95         |
|           |  |                |      |      |                         |                 |
|           | Royalty & Carriage=                          |                |      |      |                         | 9993.20         |
|           | 13.5 x 402.38 + 6.75 x 524.24 + 6.05x169.00= |                |      |      |                         |                 |
|           | 5432.13 + 3538.62 + 1022.45 =                |                |      |      |                         |                 |
|           |  |                |      |      | <b>Total</b>            | <b>86360.50</b> |
|           |  |                |      |      | Rate per<br>Cum=5757.40 |                 |
|           | Add 1% cess                                  |                |      |      |                         | 57.57           |
|           |  |                |      |      |                         | <b>5814.97</b>  |
|           |  |                |      |      | <b>Say</b>              | <b>5815.00</b>  |



| <b>Internal Road</b> |                      |   |              |     |            |                |
|----------------------|----------------------|---|--------------|-----|------------|----------------|
|                      |                      |   |              |     |            |                |
| <b>For 1.0 mtr.</b>  |                      |   |              |     |            |                |
| E/W -                | 1.0 m x 3.5m x 0.3m  | = | 1.05         | cum |            |                |
|                      | @ Rs. 110.60/cum     |   |              |     | Rs.        | 116.13         |
|                      |                      |   |              |     |            |                |
| Sand filling         | 1.0m x 3.5m x 0.15 m | = | 0.53         | cum |            |                |
|                      | @ Rs. 261.90/cum     |   |              |     | Rs.        | 138.81         |
|                      |                      |   |              |     |            |                |
| PCC (1:3:6)          | 1.0m x 3.5m x 0.15 m | = | 0.53         | cum |            |                |
|                      | @ Rs. 4151.90/cum    |   |              |     | Rs.        | 2200.51        |
|                      |                      |   |              |     |            |                |
| M- 25                | 1.0m x 3.5m x 0.10 m | = | 0.35         | cum |            |                |
|                      | @ Rs. 5575.90/cum    |   |              |     | Rs.        | 1951.57        |
|                      |                      |   | <b>Total</b> |     | <b>Rs.</b> | <b>4407.01</b> |

## OPERATION AND MAINTENANCE ASPECTS OF SeTP / FSTP

Faecal sludge treatment plants (FSTPs) or Septage Treatment Plants (SeTPs) require ongoing and appropriate operation and maintenance (O&M) activities in order to ensure long-term functionality. O&M activities are at the interface of the technical, administrative, and institutional frameworks that enable sustained FSTP function. "Operation" refers to all the activities that are required to ensure that a FSTP / SeTP delivers treatment services as designed, and "maintenance" refers to all the activities that ensure long-term operation of equipment and infrastructure (Braustetter, 2007). Proper O&M of FSTPs / SeTPs requires a number of crucial tasks to be carried out regardless of the size of the plant, and complexity of the technological setup. Having skilled workers perform these tasks in a timely manner and in accordance with best practices will maximise the value of the FSTP / SeTP and ensure its long-term performance.

Many FSTPs / SeTPs fail following construction, regardless of the choice of technology or the quality and robustness of the infrastructure. Reasons for failure are not always investigated, but the most frequent explanations given are low operational capacity (Fernandes *et al.*, 2005; Lennartsson *et al.*, 2009; Kone, 2010; HPCIDBC, 2011), and the lack of financial means to accomplish O&M tasks (Kone,2002). Lessons learned from these failures are that O&M must be considered as an integral component of the full life cycle costs of a facility, and that ongoing training and capacity building is essential for the operators. In addition, the O&M plan must be incorporated into the design process and receive appropriate review and approvals along with the engineering plans. This helps to ensure that O&M is fully integrated into the facility once construction is complete and operation has begun. Financial, technical and managerial inputs are needed to ensure the continuous operation of even the simplest of FSTP/SeTP systems. The procedures that establish how the treatment facility and equipment are utilised, are documented in several O&M plans, monitoring programmes, reports and log books, and health and safety plans, which outline the step-by-step tasks that employees are required to carry out in order to ensure the long-term functioning of the FSTP/SeTP. While many O&M activities are process specific, others are common to all facilities and all O&M Plans should therefore, include information on:

- the procedures for receiving and off-loading of faecal sludge (FS) at the FSTP/SeTP;
- the operation of specific technologies such that they function as designed;
- maintenance programmes for plant assets to ensure long-term operation and to minimise breakdowns;
- the monitoring and reporting procedures for the FSTP/SeTP O&M activities as well as the management of treatment end products;

- management of health and safety aspects for protection of the workers and the environment;
- the organisational structure, distribution of and the management of administrative aspects; and
- procedures for the onsite storage of FS and the off-site transportation.

The level of organisation required at any given FSTP/SeTP is a function of its size and treatment capacity. Small systems that receive a few loads of FS a week may only need one operator, and therefore have relatively simple O&M plans, while large municipal systems that receive FS loads around the clock are more complex and require more staff with different levels of operators and maintenance personnel. This chapter discusses the O&M planning process as well as the specific components of the O&M Plan. It references the procedures and tasks that are common to all FSTP/SeTP facilities, as well as considerations for technology specific tasks.

### **O&M Planning During Project Development Phase**

There are several important factors that need to be considered when planning FSTPs / SeTPs which will have a direct impact on O&M and monitoring. They encompass both classical engineering aspects of technology integration, as well as other issues concerning the institutional management that defines the FSM programme. Since O&M aspects are important for the overall long-term success of the programme, O&M planning, including the financial provision of funds, should be included in the terms of references for the design of each FSTP (Fernandes *et al.*, 2005; Luthi, 2011). Furthermore, the O&M plan should be reviewed and approved along with engineering designs and specifications, including the following considerations:

- location of the FSTP and its proximity to residential areas;
- volumes and schedules of FS collection;
- availability of local resources;
- degree of mechanisation of technologies; and
- final end use or disposal of end products.

#### **Location**

The location of a FSTP is a crucial aspect when designing an O&M plan. FSTPs /SeTPs are often associated with nuisances such as odours, flies and mosquitoes, and noise. Facilities located close to residential areas must therefore install preventative controls, all of which have O&M implications. Examples include FSTPs/SeTPs that utilise waste stabilisation ponds located near to residential areas, where mosquito control is an important requirement. For FSTPs/SeTPs located such that access roads cross residential areas, reduction of noise and dust produced by trucks needs to be regulated.

Other site specific factors that might influence O&M activities and costs include:

- soil conditions, such as soil depth and bearing capacity, that might have impact on equipment selection and installation;
- groundwater level and proximity of the FSTP/SeTP that could result in pollution of water resources or infiltration of groundwater into treatment tanks, directly impacting on the pumping and solids handling equipment; and

- surface waters and flooding risks, which might inhibit site access during rainy seasons, adversely affect or undermine equipment due to scouring or erosion.

### Volume

The volume of FS that is collected and delivered to the treatment plant, as well as the operational times of the FSTP/SeTP will have a significant influence on the O&M costs and requirements. Cultural habits or events can influence the volumes that are discharged at the FSTP/SeTP at different times of the year. Similarly, seasonal variability of waste volumes will impact O&M staffing requirements. Larger systems that operate on a daily basis have very different staffing requirements to those that operate intermittently.

The distribution of the FS volume received at the plant throughout the day is critically important in the planning process, as low or high flows that exceed the design of the treatment system can have a significant impact on the operational efficiency. The initial planning phase must therefore ensure that the chosen technology is appropriate for local conditions, and that it is correctly sized to accommodate the expected volumes and related fluctuations. Institutional arrangements that closely coordinate activities between facility owners and those responsible for the FS collection and transportation can help to address these issues.

### Local Resources

The availability of local resources impacts not only those aspects that determine the cost of construction such as technology selection and building materials but also on the costs of O&M requirements. Local resource issues that must be considered from the O&M perspective include:

- the availability of spare parts and tools;
- the availability of consumables (e.g. chemicals for flocculation);
- the availability and reliability of local utilities including water and power;
- the availability of trained human resources to properly operate the facility;
- the availability of local laboratory resources that may be required for monitoring programs; and
- the availability of local contracting firms to assist with periodic tasks that may be labor intensive, or require very specific skills.

Ideally, equipment that can be maintained and repaired within the country should be used. If no local supplier is available, fast delivery and repair services need to be ensured, or adequate replacement components must be stocked at the plant. For example, the powerful vacuum trucks that are needed to empty settling-thickening tanks require specific maintenance skills, which are often not locally available in mechanical workshops. It is therefore recommended that contracts be prepared during the equipment acquisition process whereby conditions for the repair services, for example, the annual maintenance of vacuum trucks, is defined. When designing FSTPs/SeTPs that require the addition of consumables for the treatment process (e.g. lime or chlorine), the costs and availability of these needs to be assessed, as well as the requirements for safe storage. Other aspects that impact on O&M costs include emergency operation procedures during power or water outages, and any shipping or transportation charges for delivery of samples requiring laboratory analysis. The choice of technology should therefore not only be made based on installation costs, but also O&M costs.

### Adoption of technology

The degree of mechanisation of the FSTP/SeTP depends on the availability of spare parts, electrical power and trained operators. Where this is limited, passive technologies such as drying beds and stabilisation ponds might be better technology choices which has been the case in this project. If power availability is intermittent, technologies that utilise manual systems should be chosen over mechanical ones whenever possible. For example, screenings can be removed manually or by a mechanical rake, dried sludge can be transported with a mechanical shovel or with a wheelbarrow, and small composting piles can be mechanically aerated, while compost heaps need to be turned manually. Provisions for such items are to be made in the O&M cost estimates.

### End use or disposal

The end use or disposal of the treatment end products has an influence on the technologies and processes needed to achieve the required level of treatment. This in turn, has a significant impact on the costs and skill levels required to operate and maintain equipment. In a simple SeTP where sludge is dried for disposal in a landfill or for end uses such as combustion, both of which do not require high pathogen reduction, less rigorous treatment and lower O&M costs are involved compared to a system that produces end products for use on food crops that are directly ingested without cooking (e.g. salad greens). Determining if the value associated with the end use activities is outweighed by the technology and O&M costs needed to achieve the required levels of treatment is a key driver for SeTP technology design. Understanding the costs associated with the specific O&M and monitoring tasks for identified end use activities assists in the planning of a FSM programme.

### **O&M PLAN**

This includes details on the tasks, materials, equipment, tools, sampling, monitoring and safety procedures which are necessary to keep the plant running properly, all of which have cost implications that must be carefully considered.

### Operation Procedure

FSTPs require clear operational procedures. Therefore, the O&M plans should include an operation manual, containing the following information:

- the as-built engineering drawings and FSTP specifications;
- the manufacturer's literature and equipment operation guidelines;
- the responsible person for each task;
- the frequency of each activity;
- the operation procedures and tools required to perform the task;
- the safety measures required; and
- the information that is to be monitored and recorded.

If chemicals or other consumables are required for the operation of a specific component, they should also be listed together with the name of the supplier and information on how they are to be used and stored. If some operational activities require the use of external companies, or if a transport company is needed to discharge the end products, their contact and description should also be given in the operation manual. The operation manual must also have a special section for emergency or non-routine operations requirements. Procedures should be planned for specific cases such as extreme climatic events, power shortages, overload, degradation of a pump, basin or canal, and other accidents. All procedures provided in the operation manual must be prepared in order to ensure conformance with the local laws and standards. The treatment technologies require the control of the following aspects:

- screenings removal;
- load (quantity, quality and frequency);
- processing (e.g. mixing compost pile, chemical addition for mechanical drying);
- residence time;
- extraction, further treatment or disposal of end products;
- collection and further treatment or disposal of liquid end products; and
- storage and sale of the end products.

The operational procedures should take the climate and the other context-dependent variables into account. The drying time or retention time may vary greatly during intensive rain periods or droughts. Rain events may also increase FS volumes delivered to the FSTP if the onsite sanitation systems were not built adequately, due to runoff or a rise in the groundwater table. The operational activities at the FSTP can then be planned to take these aspects into account. For example, macrophytes of planted drying beds can be weeded during a dry season, when there is potentially less FS to treat, and there is a shorter drying time.

The operational procedure also needs to take the FS characteristics (e.g. viscosity, amount of waste, fresh or partly stabilised sludge), and the required level of treatment into account. The information collected through the monitoring system also needs to be considered in order to improve the operational procedure and planning. For example, the frequency of sludge extraction from a settling-thickening tank or from a waste stabilisation pond can be adjusted based on the observed quantity of sludge accumulated over time.

### Maintenance Procedure

There are two main types of maintenance activities: preventative maintenance and curative maintenance. Well-planned preventative maintenance programs can often minimise curative interventions to emergency situations, which are frequently costlier and complex. Component breakdowns at FSTPs can result in wider system failure, or non-compliance. Therefore, each component at the FSTP has specific preventative maintenance requirements that need to be described in detail in a maintenance plan including the tasks, frequency of actions, and step-by-step procedures for accomplishing the tasks, including inspections. Physical inspections conducted at scheduled intervals are important, where operators look for specific indicators such as cracked wires broken concrete and discoloured and brittle pipes in order to identify preventative maintenance needs.



The maintenance plan should be guided by the local context, the climate, and the asset-specific monitoring information. Coastal FSTPs/SeTPs, for example may require more frequent painting and corrosion control due to the salt air compared to the same plant located inland. The task details include the equipment, tools and supplies needed to accomplish the task and the amount of time it should take to complete. Once completed, the task details should be entered into the equipment maintenance log book or database, along with any difficulties encountered. Frequent maintenance tasks include:

- corrosion control – scraping rust, painting metal surfaces, and repairing corroded concrete;
- sludge and coarse solids extraction from the basins and canals;
- repacking and exercising valves (i.e. locating and maintaining fully operational valves);
- oiling and greasing mechanical equipment such as pumps, centrifuges or emptying trucks; and
- housekeeping activities including picking up of refuse and vegetation control.

Other aspects of maintenance include establishment of a laboratory facility for close monitoring of treatment process. Since septage can be brought from various sources with varied degree of pre-stabilization, the operation shall need to be favourable to the sludge characteristics, the degree of treatment and the quality of end product. Similarly, record keeping, safety procedures and emergency procedures are also to be well defined in order to establish a standard in operation and meet any eventuality during any hazard or disaster.

A comprehensive manual on operating procedure and preventive maintenance shall be prepared by the agency executing the project and make it available to the maintenance engineer at the end preferable within three months from the completion of the project and during its trial run. The spare inventory details along with list of critical spares, if any, shall have to be listed and 40% stock procured in advance to meet any exigency.

A tentative requirement of manpower for operation and maintenance of the Faecal sludge / septage treatment plant is given in the table 4 below.

7. Cost of construction, operation and maintenance shall have to be worked out on the following items;

The economic cost calculation shall include;

- i. Cost of main structures of 20 years' durability.
- ii. Secondary structures of 10 years' durability.
- iii. Equipment and parts of 6 years' durability
- iv. Annual cost derived from above.
- v. Rate of interest per annum
- vi. Interest factor on main structures, secondary structures, and equipment
- vii. Total capital cost. (land cost may not be added in the analysis)
- viii. Cost of personnel for operation, maintenance and repair (details to be worked out)
- ix. Cost of material for operation, maintenance and repair (details to be worked out)
- x. Cost of power
- xi. Cost of treatment additives i.e. lime, chlorine etc.
- xii. Total operational cost
- xiii. Income from bio-gas (if utilised), income from fertiliser, income from effluent, tipping fees.
- xiv. Total income from the project.

### Sambalpur Septage Treatment Plant O & M Annual Estimate

| Sl. No. | Category of Staff  | No.        | Rate / Annum | Salary / wages/ Annum (Rs.) |
|---------|--|------------|--------------|-----------------------------|
| 1       | Laboratory Asst.   | 1          | 238,800.00   | 238,800.00                  |
| 2       | Electrician  | 0.1        | 222,000.00   | 22,200.00                   |
| 3       | Pump operator  | 2          | 222,000.00   | 444,000.00                  |
| 4       | Plumber  | 0.1        | 222,000.00   | 22,200.00                   |
| 5       | Watchman/ security   | 3          | 195,000.00   | 585,000.00                  |
| 6       | Sweeper  | 1          | 92,800.00    | 92,800.00                   |
| 7       | Un-skilled worker  | 1          | 92,800.00    | 92,800.00                   |
|         | <b>Total</b>   | <b>8.2</b> |              | <b>1,497,800.00</b>         |
|         | R/M of civil, electro-mechanical works @ 1.5% of c.w., i.e.<br>Rs. 19353014.00 |            |              | 290295.00                   |
|         | <b>Total</b>   |            |              | <b>1788095.00</b>           |
|         | O&M cost for 5 years   |            |              | 89,40,475.00                |
|         |  |            |              | <b>Say Rs.89,40,000.00</b>  |

# HYDRAULIC PROFILE OF TREATMENT COMPONENTS OF SAMBALPUR SEPTAGE PLANT

(Data is subject to verification after detailed survey of work site during execution)

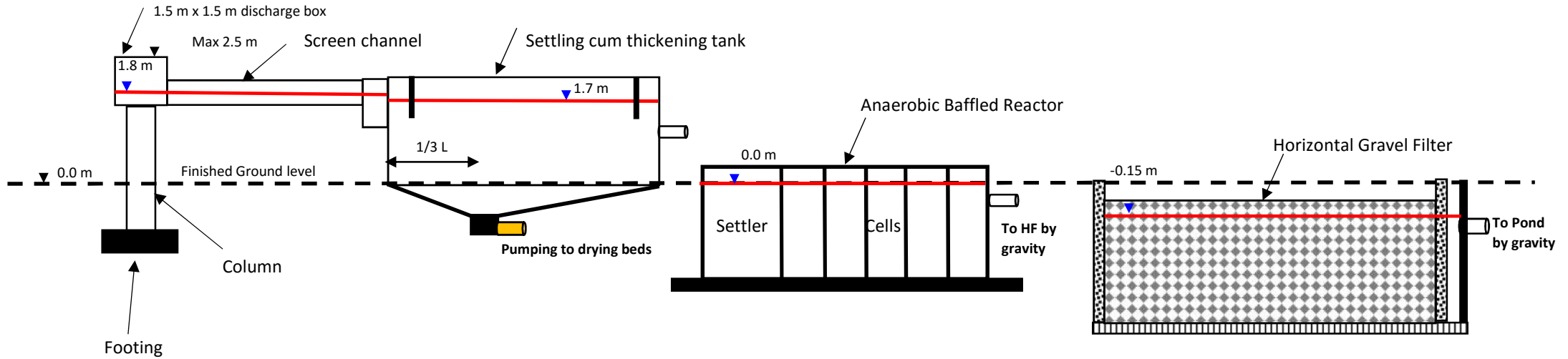

**Settling cum thickening Tank**

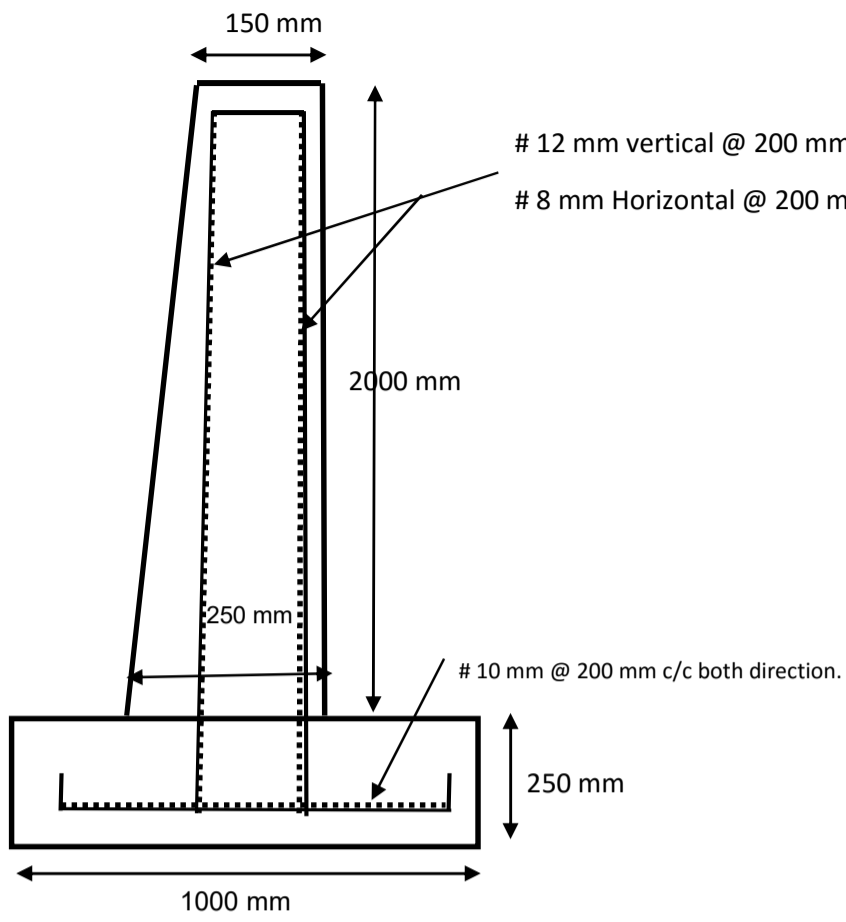

**Long and short wall reinforcement**

**Anaerobic Baffled Reactor Tank**

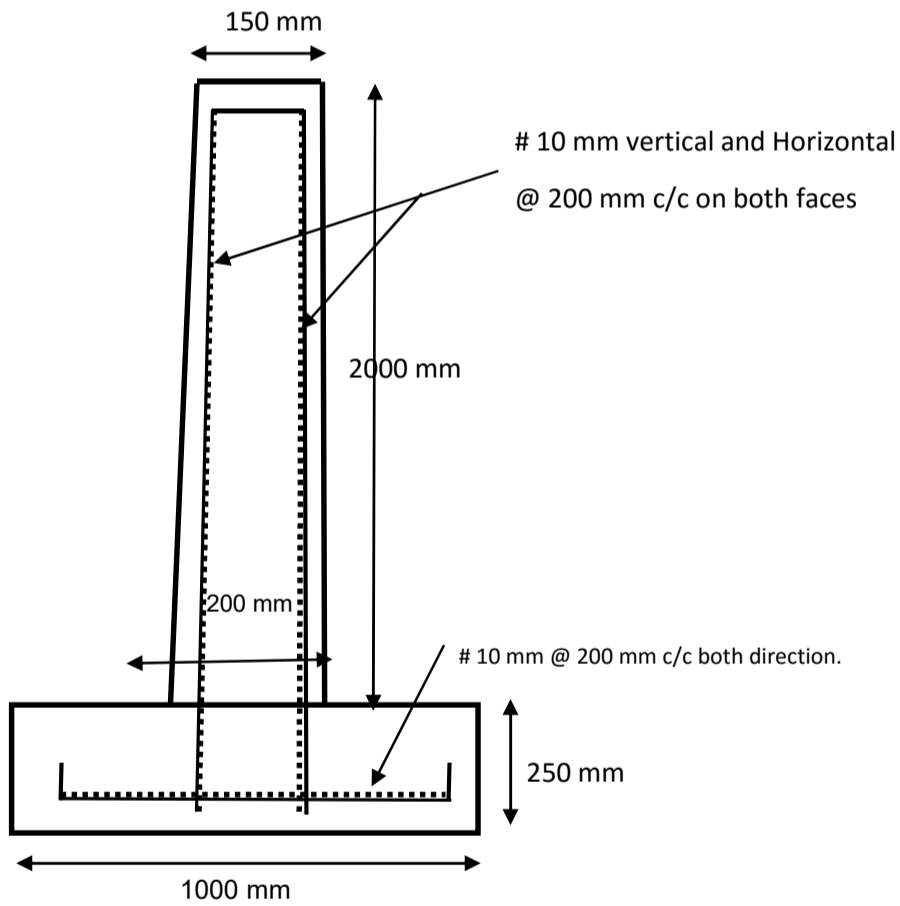

**Long and short wall reinforcement**

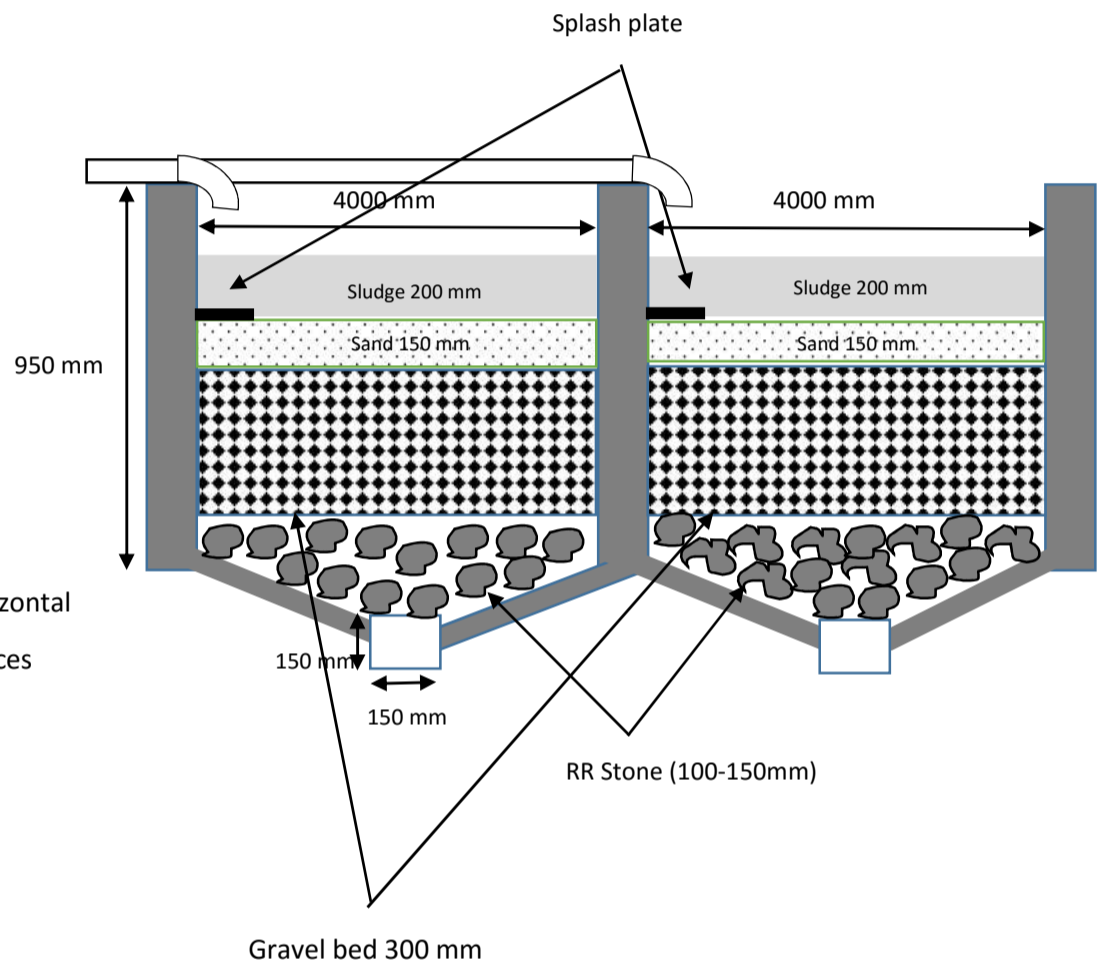
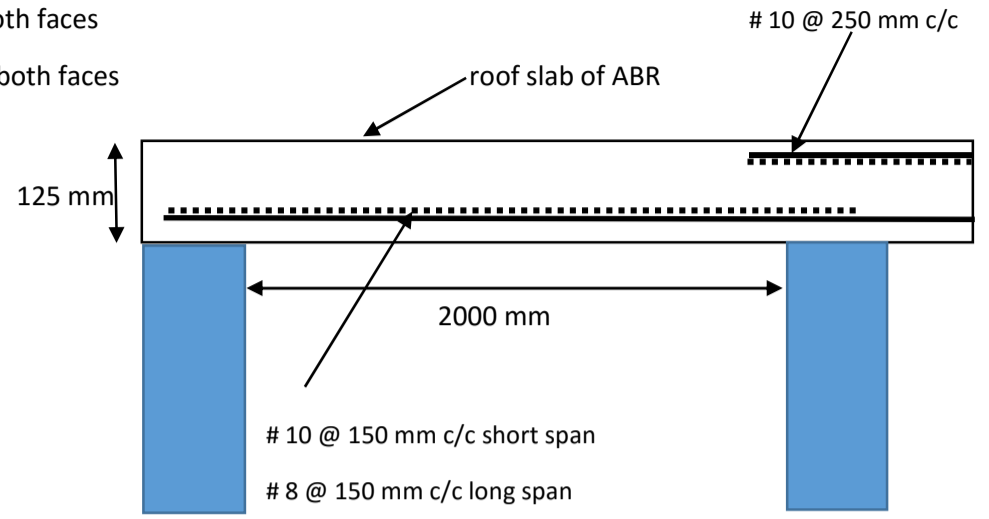

**REED BED**

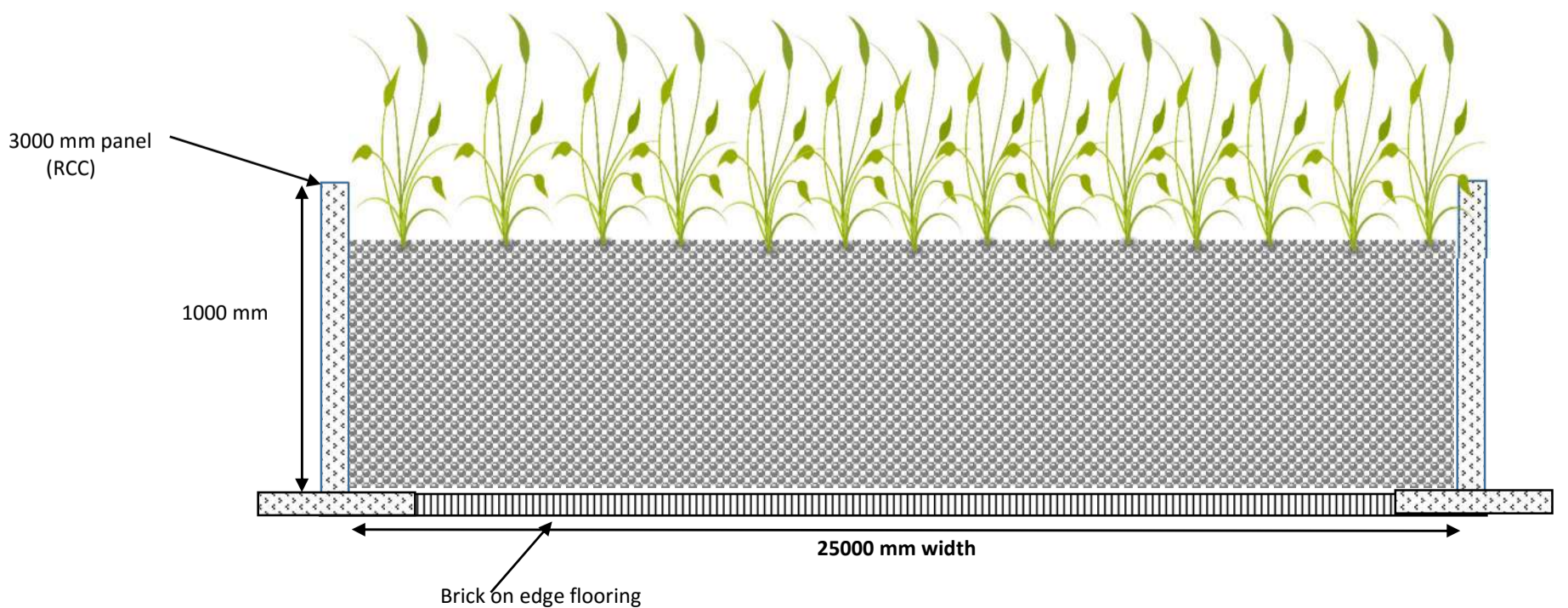

### SCHEMATIC GENERAL LAYOUT OF THE SEPTAGE TREATMENT PLANT OF 20 M<sup>3</sup> / DAY CAPACITY AT SAMBALPUR CITY, SAMBALPUR DISTRICT (to be drawn to scale during detailing)

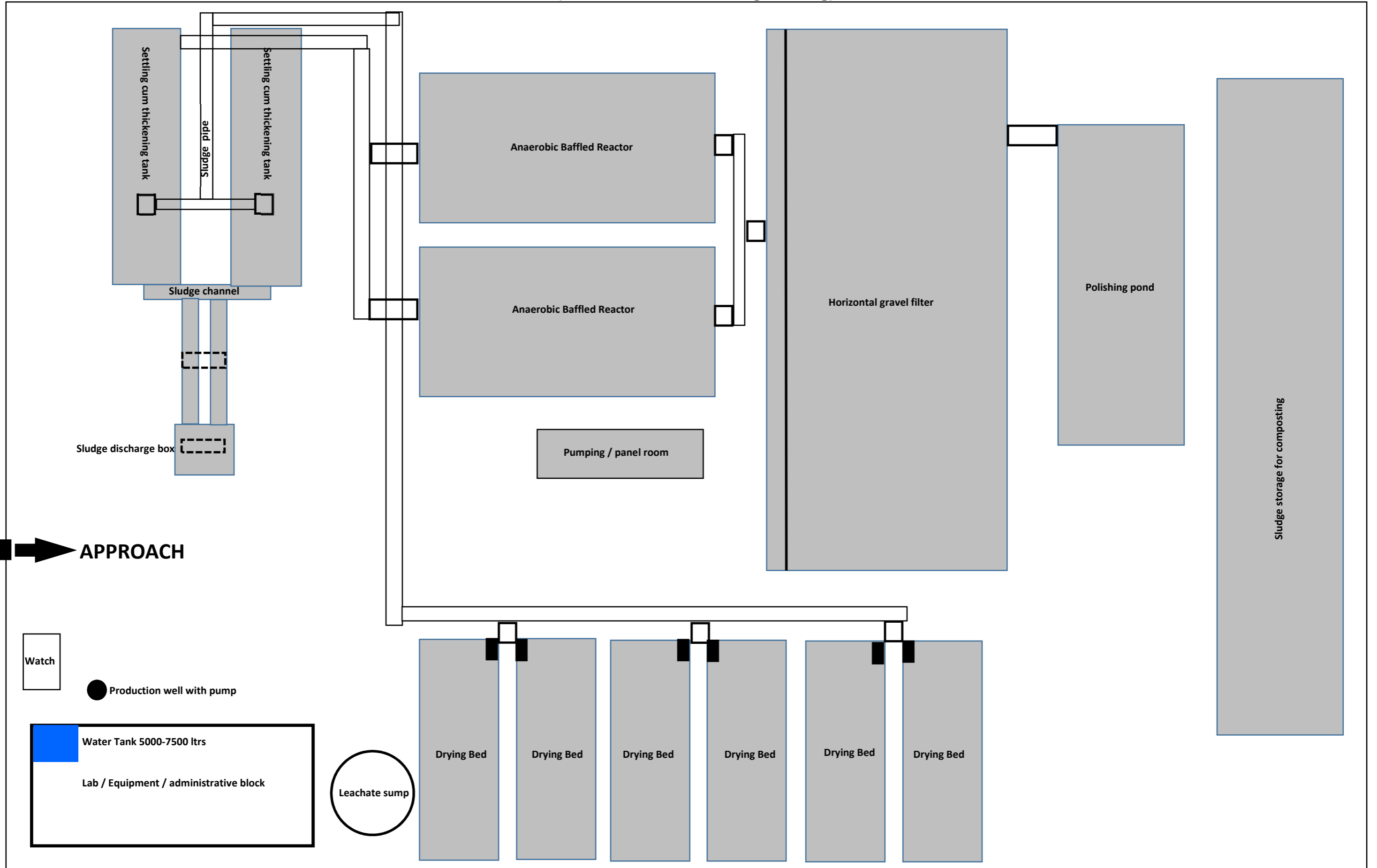



**ORISSA WATER SUPPLY AND SEWERAGE BOARD**

**TECHNICAL BID**

**BID DOCUMENT**

**COVER- I**

**NAME OF WORK:**

**Construction of Septage treatment Plant in Sambalpur Town in Sambalpur District, Odisha**

**Last date of submission : Up to 05.00 P.M. on .....2016**

**NAME OF THE SCHEME:**

Construction of Septage Treatment Plant in Sambalpur Town in Sambalpur District, Odisha - Construction of Settling-thickening tanks, Sludge drying beds, Anaerobic Baffled Reactors, Horizontal planted gravel filter, Maturation pond, Filtrate sump, Security room, CC pavement, construction of compound wall around the treatment plant, Effluent disposal arrangement, Construction of Pump Room of 12 m<sup>2</sup>, supply, delivery and installation of Non clog submersible pump sets, laboratory room, watch shed, administrative room etc. complete including Trial run for 3 Months (period of completion - 9 months )

**LAST DATE OF SUBMISSION OF BID: Up to 5.00 PM on .....2016**

**CHECK LIST TO BE ENCLOSED BY BIDDER (along with Bid Documents)**

**NIB NO. .... / SeTP/2016**

**Dated: .....**

The check list is only indicative to assist the bidder in satisfactorily enclosing all required major documents for Technical Qualification. The list is not exhaustive and the bidder should read all clauses of the bid document so as to enclose all documents as required:

**A. BID SECURITY**

- i) Bid security for a value of **Rs. 1.44 Lakhs** to be furnished
- ii) Furnish the details of Bid Security as under

| Sl. No. | Name of the Bidder | Amount and type of security | Issued by |
|---------|--------------------|-----------------------------|-----------|
|         |                    |                             |           |

**B. ELIGIBILITY/QUALIFICATION CRITERIA**

| Sl No | Description   | Requirement as per Bid document | Particulars as furnished by the bidder | Page No. with Ref. no., if any, where the particulars are furnished by bidder. |
|-------|---|---------------------------------|--|--|
|       | <b>Financial Turnover &amp; Cash flow.</b>  |                                 |  |  |
| 1.    | Average Annual Turnover for the last five financial years Rs. in Lakhs (2010-11, 2011-12, 2012-13, 2013-14 & 2014-15) –25% of BOQ value | 50 Lakhs                        |  |  |
| 2     | Net worth (10% of BOQ value)  | 15.00 Lakhs                     |  |  |
| 3.    | Minimum cash flow required in Rs. in LAKHS (10% of BOQ value)   | 15.00 Lakhs                     |  |  |

|     |   |                   |  |  |
|-----|---|-------------------|--|--|
| 4   | The bidder should have satisfactorily completed at least one work Rs.in crores in a single contract in the last five years.   | 72.00             |  |  |
|     | (2010-11 to 2014-15) - 25 % of BOQ value.   | Lakhs             |  |  |
| 5.  | Bid capacity:<br>Assessed Available Bid capacity = $(A*N*1.5) - B$  | 144.00 Lakhs      |  |  |
| 6   | <b>Physical (Work Experience)</b> Minimum aggregate during last five years 2010-11 to 2014-15   |                   |  |  |
| 6.a | Minimum aggregate experience of Pipe laying work during the last 5 years Supply, laying, jointing and testing of pumping main of any size of same materials i.e. HDPE pipes | 300 m             |  |  |
| 6.b | Minimum experience –should have Constructed and commissioned a water retaining structure of capacity more than 25 m <sup>3</sup> along with piping arrangement.             | 25 m <sup>3</sup> |  |  |
|     |   |                   |  |  |



**BID DOCUMENTS****INDEX**

| <b>Item No</b> | <b>Description of Work</b>                              | <b>Page No.</b> |
|----------------|---|-----------------|
| I              | Invitation for Bids                                     |                 |
| II             | Letter of Application                                   |                 |
| III            | Instructions to Bidders                                 |                 |
| <b>A.</b>      | <b>GENERAL</b>  |                 |
| 1.             | Scope of the Bid  |                 |
| 2.             | Method of Bidding.                                      |                 |
| 3.             | One Bid per Bidder                                      |                 |
| 4.             | Cost of Bidding.  |                 |
| 5.             | Site Visit  |                 |
| <b>B.</b>      | <b>ELIGIBILITY / QUALIFICATION CRITERIA</b>             |                 |
| 6.             | Eligible Bidder Special attention to Bidders            |                 |
| 7.             | Qualification of the Bidder                             |                 |
|                | Special attention to Bidders                            |                 |
| <b>C.</b>      | <b>BID DOCUMENTS</b>                                    |                 |
| 8.             | Contents of Bid Documents                               |                 |
| 9.             | Clarification of Bid Documents                          |                 |
| 10.            | Amendments to Bid Documents                             |                 |
| <b>D.</b>      | <b>PREPARATION OF BIDS</b>                              |                 |
| 11.            | Language of the Bid.                                    |                 |
| 12.            | Documents comprising the bid                            |                 |
| 13.            | Bid Prices  |                 |
| 14.            | Currencies of Bid and Payment.                          |                 |
| 15.            | Bid Validity  |                 |
| 16.            | Bid Security  |                 |
| 17.            | Compliance to Technical Design and Specifications.      |                 |
| 18.            | Formal and Signing of Bid                               |                 |
| 19.            | Pre Bid Meeting   |                 |
| <b>E.</b>      | <b>SUBMISSION OF BIDS</b>                               |                 |
| 20.            | Sealing and marking of Bids                             |                 |
| 21.            | Deadline for submission of Bids                         |                 |
| 22.            | Late Bids   |                 |
| 23.            | Modification substitution and withdrawal of Bids        |                 |
| <b>F.</b>      | <b>BID OPENING AND EVALUATION</b>                       |                 |
| 24.            | Bid Opening   |                 |
| 25.            | Process to be Confidential                              |                 |
| 26.            | Clarification of Bids                                   |                 |
| 27.            | Examination of Bids and determination of Responsiveness |                 |
| 28.            | Correction of Errors                                    |                 |
| 29.            | Evaluation and comparison of Bids                       |                 |

**G. AWARD OF CONTRACT**

30. Award Criteria
31. Employers Right to accept any Bid and to Reject any or all Bids
32. Notification of Award
33. Registration with State Govt.
34. Performance Security
35. Signing of Agreement
36. Mobilization Advance
37. Forfeiture of performance Security

**IV. PROGRAMME SCHEDULE**

38. Project completion and Milestone
39. Programme Schedule/Rate of progress/Milestone
40. Penalty for Defective construction
41. Liquidated damages
42. Foreclosure of works

**V. PAYMENTS AND RECOVERIES**

43. Payment Schedule
44. Release of performance security and Retention amount
45. Recovery of money payable to OWSSB
46. Income Tax
47. Sales Tax
48. Excise duty
49. Fund contribution for manual workers
50. Price Adjustment

**VI. LIST OF ANNEXURES AND CERTIFICATES****Annexures:**

- 1) Performance of the Bidder showing total monetary value of Civil Engineering work for the past Five years (Annexure-I)
- 2) Average Annual Construction Turnover (Annexure-II)
- 3) Experience in works of similar nature and Magnitude within a period of 5 years (Annexure-III)
- 4) Commitment of works on hand (Annexure-IV)
- 5) Works for which Bid already submitted (Annexure-V)
- 6) List of Equipment available with bidder (Annexure-VI)
- 7) Qualification/Experience of key personnel proposed for technical and administrative functions under this contract (Annexure-VII)
- 8) Sample Format for evidence of access to or availability of credit facilities (Annexure-VIII)
- 9) Details of Litigation if any(Annexure-IX)
- 10) Declaration by the bidder pertaining to blacklisting / debarment etc. (Annexure-X)
- 11) Details of components proposed to be sublet and Sub contractor involved (Annexure-XI)
- 12) Technical staff to be employed (Annexure-XII)

**Certificates:**

- 1) Signature of the proprietor or proprietress attested by the Notary Public.
- 2) Signature of all the partners/power of attorney attested by the Notary Public.
- 3) Registration of the firm, signature of the authorized person attested by the Notary public.
- 4) A copy of the listed power of attorney authorizing the signatory of the bidder.
- 5) Proof of registration of firm/company.
- 6) Audited Balance sheets.
- 7) Credit line certificate from Financial Institutions.
- 8) Income Tax clearance certificate.
- 9) Sales Tax verification certificate.
- 10) Certificate of performance issued by not less than the rank of Executive Engineer / Responsible person of the private organization.

**VII GENERAL CONDITIONS OF CONTRACT**

1. Definitions
2. Interpretations
3. Authority of Engineer In-charge
4. Sufficiency of Bid.
5. Priority of Contract Documents -
6. Secrecy of the Contract Documents
7. Instructions in Writing.
8. Commencement of Works
9. Reference Marks.
10. Supervision
11. Subletting of contract
12. Specification and Checks.
13. Custody and Supply of Drawings and Documents
14. Bill of Quantities.
15. Change in the Quantities
16. Additional Items
17. Order Book
18. Independent Inspection
19. Covering and Opening of Works
20. Temporary Diversion of Roads and Commencement of Work
21. Notice to Telephone, Railway and Electric Supply Undertaking
22. Watching and Lighting.
23. Measurement of Work.
24. Tools and Plants.
25. Information and Data
26. Co-existence with other Contractors.
27. General Responsibilities and Obligations of the Contractor
28. Labour
29. Restriction of Working Hours.
30. Right of Way and Facilities.
31. Removal of Improper Work. Material and Plant.
32. Default of contractor in Compliance.
33. Default by Contractor.
34. Power to vary Work.
35. Extra for Varied Works.
36. Omissions.
37. Notices regarding Shoring etc.

38. Cost of Repairs.
39. Suspension of Works.
40. Suspension of Progress.
41. Termination.
42. Plant etc. not to be removed.
43. Contractor not to occupy Land etc.
44. Power Supply.
45. Completion and Delivery of the Works.
46. Final Certificate.
47. Completion Certificate.
48. Taking Over
49. Performance Guarantee
50. Trial run of the Project
51. Operating and Maintenance Manual.
52. Work on Private Property.
53. Protection.
54. Accident or Injury to Workmen.
55. Risk Insurance.
56. Care and Risk
57. Safety Provisions
58. Provision of Health and Sanitary Arrangements.
59. Patent Rights.
60. Royalties.
61. Old Curiosities.
62. Contractor Dying, becoming Insolvent or Insane.
63. Force Majeure
64. Payment out of Public Funds
65. Bribery and Collusion
66. Technical Audit
67. Jurisdiction of Court
68. Reservation of Right

### **VIII SPECIAL CONDITIONS**

1. Additional condition as per G.O. Ms 293 / MA&WS / dt: 26-11-2010

Letter of Negotiation.

Forwarding slip to Lumpsum Agreement. Form  
of Agreement (Lumpsum) Indemnity Bond.

Indemnity Bond (in lieu of water tightness and structural stability)

Performance Bank Guarantee (Unconditional)

Bank Guarantee for Advance Payment. Bill of  
Quantities.



**ORISSA WATER SUPPLY AND SEWERAGE BOARD**

**TENDER CALL FOR SEPTAGE TREATMENT PLANT**  
**FORM OF CONTRACT: (LUMP SUM TWO COVER SYSTEM)**

**INVITATION OF BID NO. ... /SeTP/2016**

1. For and on behalf of Orissa Water Supply and Sewerage Board, bids (in Two-cover System) under lump sum contract are invited by the Member Secretary, OWSSB, as detailed below.
2. Bidding documents in English may be downloaded by interested bidders from the Government web site [www.odisha.gov.in](http://www.odisha.gov.in) of Government of Odisha.
3. Cost of tender document is Rs.10000 + 5% VAT.
4. Amount of Earnest Money Deposit will be **1,50,000.00**.
5. Period of contract is as furnished below in respect of this work.
6. Pre Bid Meeting will be held **on .....** at **11.00** hours in Head Office of OWSSB at Satyanagar, Bhubaneswar.
7. Further details about work can be seen in bidding documents and can also be got from office of the Project Engineer, P.M. Unit, Sambalpur, OWSSB.

| Sl. No. | Name of the Work   | Value put to Tender | Period of sale and contact person | Last date of submission of bids | Date and time of opening of technical bid |
|---------|--|---------------------|-----------------------------------|---------------------------------|---|
| 1       | 2  | 3                   | 4                                 | 5                               | 6   |
| 1       | Construction of Septage Treatment Plant in Sambalpur Town in Sambalpur District, Odisha - Construction of Settling-thickening tanks, Sludge drying beds, Anaerobic Baffled Reactors, Horizontal planted gravel filter, Maturation pond, Filtrate sump, Security room, CC pavement, construction of compound wall around the treatment plant, Effluent disposal arrangement, Construction of Pump Room of 12 m <sup>2</sup> , supply, delivery and installation of Non clog submersible pump sets, laboratory room, watch shed, administrative room etc. complete including Trial run for 3 Months (period of completion - 9 months ) |                     |                                   |                                 |   |

The undersigned reserves the right to reject any or all the bid documents without assigning any reasons therefore.

Member Secretary, OWSSB

Please visit our website [www.odisha.gov.in](http://www.odisha.gov.in) for further details

## **II. Letter of Application**

(Letter head paper of the Applicant, including full postal address, telephone no., fax no., cable address, and e-mail)

Dated

To

**The Member Secretary,  
OWSSB, Satyanagar,  
Bhubaneswar 751 007**

Dear Sir,

Being duly authorized to represent and set on behalf of

(hereinafter “the Applicant”),

and having reviewed and fully understood all the information provided, the undersigned hereby apply for consideration as a bidder for the following

**IFB NO. .... / SeTP/2016.**

Construction of Septage Treatment Plant in Sambalpur Town in Sambalpur District, Odisha - Construction of Settling-thickening tanks, Sludge drying beds, Anaerobic Baffled Reactors, Horizontal planted gravel filter, Maturation pond, Filtrate sump, Security room, CC pavement, construction of compound wall around the treatment plant, Effluent disposal arrangement, Construction of Pump Room of 12 m<sup>2</sup>, supply, delivery and installation of Non clog submersible pump sets, laboratory room, watch shed, administrative room etc. complete including Trial run for 3 Months (period of completion - 9 months )

Attached to this letter please find copies of original documents defining

- the Applicant’s legal status
- the principal place of business and
- the place of incorporation (for applicants who are corporation) or the place of registration and the nationality of the owners (for applicants who are partnerships or individually owned firms)

Your Agency and its authorized representatives are hereby authorized to conduct any inquiries or investigations to verify the statements, documents and information submitted in connection with this application, and to seek clarification from the bankers and clients regarding any financial and technical aspects. This ‘Letter of Application’ will also serve as authorization to any individual or authorized representative of any institution referred to in the supporting information, to provide such information deemed necessary and requested by yourselves to verify the statements and information provided in this application, or with regard to the resources, experience and competence of the Applicant.

This application is made in the full understanding that:

- bids by the applicants will be subject to verification of all information submitted for consideration, at the time of bidding.

Your Agency reserves the right to:

- amend the scope and value of any contract bid under this project

- and reject or accept any application, to cancel the entire bidding process and reject all the applications and
- Your Agency shall not be liable for any such action and shall be under no obligation to inform the Applicants of the grounds for them

It is hereby certified that the unit rates and price for all the items covered in the Bill of Quantities set out in the Price Schedule have been furnished clearly in figures and words and it is hereby agreed to execute the works at the rates and prices mentioned therein and to receive the payments on measured quantities as per the Conditions of the Contract.

It is hereby distinctly and expressly declared and acknowledged that before the submission of the bid, the instructions therein have been carefully followed and the conditions of the Contract and other terms and conditions have been read. It is also declared and acknowledged that careful examination of the bid documents has been carried out with reference to the specifications, quantities, location where the said work is to be done, investigation of the works to be done, materials required for this contract and their source and other requirements, covenants, stipulations and restrictions. It is distinctly agreed that no claim or demand will be made on OWSSB by the applicant, arising out of any misunderstanding or misconception or mistake of the said requirements, covenants, stipulations, restrictions, conditions etc. on the part of the applicant.

The Income Tax Clearance Certificate and Sales Tax Verification Certificate in currency are enclosed

The Bid Security of **Rs. 1.44 lakhs (Rupees Three lakhs and fifty thousand only)** is enclosed in the shape of .....

(Enter the form and other details of the bid security) drawn in favour of the **Project Engineer, P.M. Unit, OWSSB, Cuttack, Odisha.**

It is hereby agreed that in case the bid is accepted, the Performance Security to the value and in the manner/form prescribed by the Employer will be submitted and agreement entered into within the time frame stipulated for the due fulfillment of the contract. It is agreed that in the event of non-remittance of the required Performance Security and execution of the Agreement within the stipulated time frame, the Bid Security deposited with the bid will be forfeited. In the event of non-acceptance of the bid offered by the Applicant, the Employer shall intimate the applicant of the rejection of his bid, upon which the applicant can get his Bid Security refunded on an application for the same. Any notice required to be served on the applicant shall be deemed to have been sufficient if delivered personally or left at the address given herein or sent by post either by registered mail or ordinary. Such notice shall, if sent by post shall be deemed to have been served on the applicant at the time when in due course of post it would be delivered at the address to which it is sent. For all purposes, the address given herein will serve as permanent address and any change therein will be promptly intimated then and there.

It is fully understood and agreed that on receipt of communication of acceptance of the bid from the accepting authority, there emerges a valid contract between the Applicant and OWSSB represented by the officer accepting the bid and is expressly agreed that the bid documents with the schedules, conditions of the contract, negotiation communications and other correspondence connected to this contract will all constitute the contract for this purpose and be the foundation of rights on both the parties.



It is agreed that time shall be considered as the essence of this contract and the work will be commenced immediately on getting information of the acceptance of the bid and any slow progress will be subjected to the relevant penal clauses contained in the Conditions of the Contract

It is hereby agreed that the professionally qualified personnel to execute and supervise the works shall be deployed as required in clause 10 of General Conditions of Contract.

The Applicant hereby agrees to undertake full responsibility for the stability and soundness of the works executed.

The Applicant hereby agrees that the bid will not be withdrawn during the period of validity as indicated in the bid documents and also during such extended periods agreed to by the applicant The Applicant agrees that in the event of withdrawal of the bid during the validity period or extended period, the Bid Security is liable to be forfeited by Employer.

It is explicitly understood that the Employer is not bound to accept the lowest or any bid the Board may receive. It is hereby agreed that the Employer reserves the rights to reject any or all the bids without assigning any reasons therefor.

Dated this                      day of  
Month of

Signature of the Applicant  
(To be signed by the  
authorized signatory with seal)

**NAME OF WORK**

Construction of Septage Treatment Plant in Sambalpur Town in Sambalpur District, Odisha - Construction of Settling-thickening tanks, Sludge drying beds, Anaerobic Baffled Reactors, Horizontal planted gravel filter, Maturation pond, Filtrate sump, Security room, CC pavement, construction of compound wall around the treatment plant, Effluent disposal arrangement, Construction of Pump Room of 12 m<sup>2</sup>, supply, delivery and installation of Non clog submersible pump sets, laboratory room, watch shed, administrative room etc. complete including Trial run for 3 Months (period of completion - 9 months )

**III. INSTRUCTIONS TO BIDDERS****A. GENERAL****1. Scope of the Bid**

This is a "Procurement, Construction Contract" and the contractor is responsible for the execution of the work including the supply and installation of all materials, machineries, equipment etc. in accordance with the specifications stipulated in the Bid Document and in conformity with the Quality Parameters laid down in the relevant BIS, CPHEEO, Bid Documents etc. and completing the entire work in all respects satisfactorily and commissioning within the stipulated period.

1.1 The Member Secretary, OWSSB, Bhubaneswar (hereinafter referred as "Employer" in these documents) invites bids for the construction of works (as defined in these documents and referred as "the works") as detailed in the Bill of Quantities. The bidder shall offer their/his price for all the items of works detailed in the Bill of Quantities.

Construction of Septage Treatment Plant in Sambalpur Town in Sambalpur District, Odisha - Construction of Settling-thickening tanks, Sludge drying beds, Anaerobic Baffled Reactors, Horizontal planted gravel filter, Maturation pond, Filtrate sump, Security room, CC pavement, construction of compound wall around the treatment plant, Effluent disposal arrangement, Construction of Pump Room of 12 m<sup>2</sup>, supply, delivery and installation of Non clog submersible pump sets, laboratory room, watch shed, administrative room etc. complete including Trial run for 3 Months (period of completion - 9 months )

**Salient Details****Capacity of Treatment Plant: 50 m<sup>3</sup>/day****1. Screen Channel: 2 nos**

**Size: 0.6 m (0.3 m SWD) x 3.0 m**

**Bar screen: Bar screen 1 m wide x 1 m depth – MOC: SS 316**

**Angle of placement to horizontal 45°, placed on a support channel for easy maintenance**

**One header sludge discharge box of 1.5 m x 1.5 m RCC**

**2. Settler-cum-thickener: 2 nos.**

**L x B x D = 12 m x 2 m x 2.6 m (depth at outlet)**

**Bottom slope 1% reverse.**

**Pump / sludge pit size 1000 mm x 1000 mm**

3. **SLUDGE DRYING BED:No. of Beds: 10 nos.**  
Size of each bed: 4.00 m x 15.00 m
4. **Anaerobic Baffled Reactor: 2 nos.**  
Dimension: 13000 mm x 4000 mm x 2000 mm (1750 mm SWD)  
Settler size: 5000 mm x 4000 mm  
Up-flow reactor chamber size: 1175 mm x 4000 mm x 1750 mm SWD
5. **HORIZONTAL PLANTED GRAVEL FILTER (HPGF): 1 no**  
Area: 1200 m<sup>2</sup> (40 m x 30 m)  
Slope: 1%, depth at entrance: 0.6 m
6. **Maturation Pond: 1 no**  
Pond area = 45 m<sup>2</sup>, size: 6 m x 7.5 m  
Pond depth = 1.0 m
7. **Leachate Sump: 1 no**  
Diameter: 2.5 m  
Depth: 4.0 m
8. **Pump Sets:**
  - a. **Submersible pump at maturation pond: 2 nos.**  
Capacity: 3 - 5 kW
  - b. **Sludge pump at Thickener: 2 nos.**  
Capacity: 7.5 kW
  - c. **Submersible at leachate sump: 2 nos.**  
Capacity: 5 kW
9. **Pump rooms, Laboratory,  
Watch shed, Administrative block: 85 m<sup>2</sup>**
10. **Electrical sub-station of 25 kVA capacity: 1 no**
11. **Open shed for co-composting: 200 m<sup>2</sup>**
12. **Construction of BT/CC road / pavement inside plant: 1 km**
13. **800 mm size production well: 1 no.**

**14. Overhead water tank of 7,500 litres capacity.**

**15. Piping work of HDPE / DI material:2000 m**

**16. Yard Lighting and compound wall of 330 m**

**17. Site development, plantation and land scaping**

**1.2 Trial run of the Scheme (After successful commissioning of the project) – 3 Months.**

1.3 The successful bidder will be expected to complete the works within the period stipulated for completion in the programme schedule.

1.4 In these bidding documents, the terms bid and tender and their derivatives (bidder / Bidder, bid/tender, bidding/tendering etc) are synonymous.

**1.5 Downloading the documents from web site.**

The documents are to be downloaded from the web site: [www.odisha.gov.in](http://www.odisha.gov.in) by the Bidder and offer their tender duly filled and signed along with all required documents to the tender inviting authority as notified in the IFB subject to the following.

- a) The bidder shall furnish a certificate to the effect that no correction/ alteration on the bid document as found in the web site was made by him and he shall abide by all the terms, conditions and specifications contained in the bid document.
- b) Cost towards bid document shall be required to be paid by the bidders who are using the forms downloaded from the designated website.

The bidder shall submit the tender to the tender inviting authority as prescribed in the IFB.

## **2. Method of Bidding**

2.1 If the bid is made by an individual, the bid documents shall be signed by the individual with his full name and current address.

2.2 If the bid is made by a proprietary concern, the bid documents shall be signed by the proprietor with his full names as well as the name of the firm and full address. In the case of an authorised person holding power of attorney signing the bid documents, a certified copy of the registered power of attorney should accompany the bid documents. The signature of the proprietor shall be attested by a notary public and enclosed as documentary evidence.

2.3 If the bid is made by a partnership firm, the bid documents shall be signed by all the partners of the firm along with their full names and current address with specific mention on the registered address of the firm. In the case of a partner holding power of attorney signing the bid documents, a certified copy of the registered power of attorney should accompany the bid. It is also mandatory to furnish a certified copy of the registered partnership deed, current address of the partners, registered address of the firm along with the bid. The signature of all the partners/ power of attorney shall be attested by a notary public and enclosed as a documentary evidence.

2.4 If the bid is made by a limited company or a limited corporation, it shall be signed by a duly authorised person holding power of attorney for signing the bid documents in which case a certified copy of the registered power of attorney shall accompany the bid. Such limited company or corporation may be required to enclose satisfactory evidence of its existence along with the bid.

2.5 The bids from the contractors / firms shall be accompanied by an attested copy of the Income Tax Clearance Certificate and Sales Tax Verification Certificate relating to the year prior to the previous financial year.

### 3. One Bid per Bidder

3.1 Each bidder shall submit only one bid for the whole scheme and in the case of packages, only one bid for a package. A bidder who submits or participates in more than one bid (other than sub-contractors) will be disqualified.

### 4. Cost of Bidding

4.1. The bidder shall bear all the costs associated with the preparation and submission of his bid. The Employer will in no case be responsible for those costs, regardless of the conduct or the outcome of the bidding process.

### 5. Site Visit.

5.1. The bidder, at the Bidder's own responsibility and risk is advised to visit and examine the site of works and its surroundings and obtain on his own all information that may be necessary for preparing the bid and entering into contract for the construction of the works. The costs of visiting the site and its surroundings shall be at the bidder's expense. Site levels, Soil data made available are only for the information of bidder and the employer is not responsible for their correctness.

5.2 The bidder and any of his personnel or agents will be granted permission by the Employer to enter upon its premises and lands for the purpose of such visit, but only upon the express condition that the bidder, his personnel or agents, will release and indemnify the Employer and his personnel or agents from and against all liability in respect thereof, and will be responsible for death or personal injury, loss of or damage to property, and any other loss, damage, costs and expenses incurred as a result of the inspection.

5.3 The bidder should carefully inspect the site to assess the prevalence of differing soil classifications and quote the rate for trench excavation for laying pipeline taken into account of all soil classifications that are likely to be encountered and no extra rate will be paid for excavation of trench on account of any variation in the classification of soil met with during actual execution

## **B. Eligibility / Qualification Criteria**

### **6. Eligible Bidders**

- 6.1 The Invitation to Bid is open to any bidder meeting the following requirements:
- 6.2 A bidder shall not be associated nor has been associated in the past, directly or; indirectly, with the Consultant or any other entity that has prepared the design, specifications and other documents for the project.
- 6.3 A bidder shall not be associated directly or indirectly with the firm engaged by the Board for providing consultancy services for the preparation and supervision of the works and any of its affiliates.
- 6.4 Bidders shall provide such evidence of their continued eligibility satisfactory to the Employer as the Employer shall reasonably request.
- 6.5. Joint Venture will not be accepted.

### **7. Qualification of the Bidder**

#### **7.1 General**

- 7.1.1 Bidders shall provide the following as part of their bid in the prescribed formats.
- 7.1.2 A registered power of attorney authorizing the signatory of the bid to commit on behalf of the bidder should be enclosed.
- 7.1.3 Proof of registration of the firm/company under companies Act should be enclosed.
- 7.1.4 Total monetary value of Civil Engineering works performed during each of the last Five years should be furnished in Annexure – I.
- 7.1.5 Annual turnover (Civil Engineering works) for the past Five financial years (Audited balance sheet for the last Five financial years) should be enclosed. Annual turnover for the past Five financial years should be certified by a registered Chartered Accountant and the certificate should be affixed with the seal of the office of the Chartered Accountant with the registration number legibly in Annexure – II.  
The contract receipt / contract income of the audit profit and loss account or audited income and expenditure account shall only be considered for the purpose of annual Turnover (Civil Engineering Works) for the past Five financial years.
- 7.1.6 Experience in works of similar nature and magnitude during each of the previous Five financial years, the details of works on hand and works for which bid already submitted should be furnished in the Annexure – III, IV and V respectively.
- 7.1.7 List of equipment available with the bidder for deployment in the project should be furnished in Annexure – VI.
- 7.1.8 Technical, administrative and managerial personnel proposed to be employed for key site management in this work with their qualification details should be furnished in Annexure – VII.

- 7.1.9 Evidence of access to lines of credit and availability of other financial resources, Credit line certificates from financial institutions should be enclosed in Annexure – VIII.
- 7.1.10 Litigation details of the bidder with the details of the parties concerned and the amount involved should be furnished in Annexure – IX.
- 7.1.11 The bidder should declare clearly whether the bidder has been black listed, banned or debarred in Central or any other State Government / Union Territory / Public Sector undertaking (State/Central) organization in Annexure – X.
- 7.1.12 Deleted
- 7.1.13 Income Tax Clearance Certificate in currency as proof of having remitted the income tax for the year prior to the previous financial year (with reference to the year in which the bid is opened)
- 7.1.14 Sales Tax Verification Certificate as proof of having remitted the sales tax. In the case of not liable to the Sales Tax Department, a valid certificate issued by the competent authority to this effect.

**Conditions to be satisfied:****7.2 Performance Eligibility:****a) Financial & Physical capacity:**

| <b>Sl. No.</b> | <b>DESCRIPTION</b>   | <b>CRITERIA</b> |
|----------------|--|-----------------|
|                | Financial Turn over and Cash Flow  | Rs.in Lakhs     |
| 1.             | Average Annual Turnover for the last five financial years Rs. in Lakhs (2010-11, 2011-12, 2012-13, 2013-14 & 2014-15) –25 % of BOQ value   | 50 Lakh         |
| 2              | Net worth (10% of BOQ value)   | 15.00 Lakh      |
| 3.             | Minimum cash flow required in Rs. in Lakhs<br>(10% of BOQ value)   | 15.00 Lakh      |
| 4              | The bidder should have satisfactorily completed At least one work Rs.in Lakhs in a single contract in the last five years. (2010-11 to 2014-15)  | 72.00 Lakh      |
| 5.             | Bid capacity<br>Assessed Available Bid capacity = $(A*N*1.5) - B$  | 144.00 Lakh     |
| 6              | <b>Physical (Work Experience)</b> Minimum aggregate during last five years 2010-11 to 2014-15  |                 |
| 6.a            | Minimum aggregate experience of Pipe laying work during the last 5 years Supply, laying, jointing and testing of pumping main of any size of same materials i.e. HDPE / DI pipes             | 300 m           |
| 6.b            | Minimum experience –should have Constructed and commissioned sewerage Treatment plant at least one secondary stage /industrial waste water treatment plant of capacity not less than 0.5 mld | 0.5 mld         |
| 6.c            | Minimum capacity of pump set should have supplied, erected and commissioned one pump set during the last 5 years   | 10 KW           |

Note : In addition to the above requirements the following criteria also to be satisfied.

**BID CAPACITY**

Bidders who meet the minimum qualification criteria will be qualified only if their available bid capacity is more than the total bid value. The available bid capacity will be calculated as under



Assessed Available Bid Capacity =  $[A*N*1.5-B]$

Where A = Maximum value of civil engineering works executed in any one year during the last three financial years [updated to 2015-16 (current) price level @ 6.00% per annum] taking into account the completed as well as works in progress.

N = Number of years prescribed for completion of the works for which bids are invited i.e. Nine Months.

B = Value of existing commitments and on-going works to be completed during the next One year. [Updated to 2015 – 16 (Current) Price Level]

7.3 In order to prove that the Goods offered are of acceptable quality and standard, the bidders shall furnish documentary evidence that the Goods offered have been in production and similar capacity have been sold, as indicated in the table below. **Further documentary evidence to establishment the manufacturers credential including the certificate from the manufacturing company's Auditor is requested to be submitted along with the bid.**

| Item | Goods  | Manufacturer's Experience Criteria  |   |
|------|--|---|---|
|      |  | Minimum No. of years preceding the due date of tender the goods offered are in production | Minimum average units sold per year                                       |
| 1    | Pumps, Electrical & Mechanical equipment                               |   |   |
| 1.1  | Pumps:   |   |   |
|      | Submersible Pump   | 5   | 50 Units  |
| 1.2  | Electrical Transformer   |   |   |
| 2    | Valves   |   |   |
|      | Above 200 mm size  | 5   | 200 Units**   |
| 3    | Electromagnetic / Ultrasonic Flow Meter, Electronic and ICA Equipment. | 5   | Endress and Hauser / Siemens / ABB / Krohne-Marshall or equivalent to ISI |
| 4    | Pipes  |   |   |
| 4.1  | PVC pipes  | 5   | 200% of total length required (KM)  |

**Pump sets:** Pumpset with ISI specifications of reputed brands, such as Jyothi, Kirloskar, Best & Crompton, Calama, waterman, Atlanda, KSB, Texmo, CSI , or equivalent.

\*\* Valves: Valves with ISI Specifications of reputed brands, such as Kirloskar, Venus, Upadyaya, CALSONS, Endress and Hauser / Siemens / ABB / Krohne - Marshall or equivalent

Unless otherwise stated in the Contract, the Accepted Contract Amount covers the entire Contractor's works under the Contract (including those under Provisional Sums, if any) and all things necessary for the proper design, installation, test, commission and trial operation of the Works. The Accepted Contract Amount shall cover the Works and the re-modifying of any defects.

**Note:**

- i. The performance eligibility shall pertain to the similar works executed by the tenderer in any of the Central / State Government Departments/Quasi Government Organizations and Government Undertakings, a Private Organization. The performance experience for Central / State Government Department / Undertaking / Quasi Government Organization should be supported by performance certificates issued by the concerned organization by an officer not less than the rank of Executive Engineer. **The experience certificates issued by an officer below the rank of Executive Engineer or on behalf of Executive Engineer will not be considered.**

**In case of experience of a Private Organization, the following criteria should be satisfied:**

- a) **The Photographs of the works undertaken for the Private Organization should be enclosed as a proof.**
  - b) **The certificate of the work done for the Organization be enclosed by a Senior Official who should be at least of the rank of the General Manager or Equivalent.**
  - c) **The above certificate should be countersigned by a Government Department Engineer at least of the rank of Assistant Executive Engineer and should also be Notarized.**
- ii. For the experience certificates furnished by the bidders which are obtained from the Departments outside the State, clarification will be obtained by the Employer from the concerned Department whenever felt necessary as to whether the details furnished in the certificates are genuine, before finalization of evaluation.
  - iii. The bills / claims should be prepared by the contractor as per Agreement and in accordance with the agreement executed and submitted to the Department
  - iv. Sub contractors' experience for the particular works to be sublet **shall not be taken into account for arriving at the eligibility of the contractor / firm.**
  - v. The tenderer should enter into proper agreement with sub-contractor proposed to be sub-let and furnish the documentary evidence along with bid.

**Special Condition:**

In case if a contractor/firm worked as sub-contractor previously, then their experience in those particular components of work will be considered only if their sub contract/sublet **work was properly approved by the User Department**. A certified copy to that effect from Engineer in charge (not below the rank of Executive Engineer) must be produced for arriving at the performance eligibility for the particular work to be sublet.

**7.4. Disqualification:**

Even though the bidders meet the above qualifying criteria, they are subject to be disqualified at any point of time if they have

- i) made misleading or false representation in the form statements and attachments submitted and/or
- ii) Record of poor performance during the last 5 years as on the date of application such as abandoning the work rescinding of contract for which the reasons are attributable to the non-performance of the Contractor inordinate delays in completion, consistent history of litigation awarded against the applicant or any of its constituents or financial failure due to bankruptcy etc.
- iii) been debarred / blacklisted as on the date of application by any Central/State Government Department/Undertaking/Organization and their bid will not be taken up for evaluation.

**SPECIAL ATTENTION TO BIDDERS:**

- I. Copies of experience certificates obtained from the Officer not below the Rank of **Executive Engineer** of respective user departments must be attested by Notary Public and produced.
- II. These Certificates should contain the following details
- 1) Name of Scheme (Name of the State also to be specified)
  - 2) Contract No. and date :
  - 3) Value of contract : Rs.
  - 4) Name of contractor with full address :
  - 5) Period of completion as specified in the contract :
  - 6) Date of commencement of work :
  - 7) Actual date of completion/ commissioning :
  - 8) Reason for the delay if any :
  - 9) Full details of components executed under this contract :

**10) Performance of the work should contain the following:**

| <u>Component</u>   | <u>Performance</u>                                     |
|--|--|
| i) In case of I.W / Collection well / intake well/Jack well/Foot Bridge/ Off take Well     | : Whether completed and commissioned satisfactorily?   |
| ii) In case of pipeline work (Type of each pipe with dia, length, pressure must be given ) | : Whether completed and commissioned satisfactorily?   |
| iii) In case service reservoirs (with capacity of S.Rs. to be clearly Mentioned)           | : Whether constructed and commissioned satisfactorily? |
| iv) In case of pumping Machinery installed (The capacity of K.W. must be given)            | : Whether commissioned satisfactorily?                 |

v). In case of Water Treatment Plant  
(capacity in \_\_\_\_\_ MLD type  
components)

: Whether completed and commissioned  
satisfactorily.  
:

Signature of Officer with Seal

## **C. BID DOCUMENTS**

### **8. Contents of Bid Documents**

8.1 The Bid Documents will comprise the following documents and addenda issued in accordance with clause 10 below:

Invitation for Bids Instruction to Bidders

Eligibility/Qualification Criteria Forms of Bid

Programme Schedule and financial mile stone. Payment Schedule

General Conditions of the Contract Special Conditions of

Contract Forms of Agreement

Indemnity Bond

Forms of performance Bank Guarantee (Unconditional). Forms of Bid security (Bank Guarantee)

Technical Specifications Bill of Quantities

Drawings

### **9. Clarification of Bid Documents.**

9.1 A prospective bidder requiring any clarification may raise the same at the time of pre bid meeting in writing or by cable (hereinafter the term cable is deemed to include telex and facsimile) at the employer's address indicated in the invitation for bid. The employer will respond to any clarification sought for.

### **10. Amendment to Bid Documents**

10.1 At any time prior to 48 hours to the deadline for submission of bids, the Employer may amend the bid documents by issuing Addenda.

10.2 Any Addendum thus issued shall be part of the bid documents and shall be communicated in writing or by cable to all purchasers of the bid documents. Prospective bidders shall promptly acknowledge the receipt of each addendum by cable to the Employer.

10.3 To give prospective bidders reasonable time in which to take an addendum into account in preparing their bids, the Employer shall extend as necessary the deadline for submission of bids, in accordance with Clause 21.2 of "Submission of Bids".

## **D. PREPARATION OF BIDS**

### **11. Language of the Bid**

11.1 The bid, and all correspondences and supporting documents related to the bid exchanged by the bidder and the Employer shall be written in English. Supporting documents and printed literature furnished by the bidder may be in other language provided they are accompanied by an accurate translation of the relevant passages in English language, in which case, for purpose of interpretation of the bid, the translation shall prevail.

### **12. Documents comprising the Bid**

12.1 The bid submitted by the bidder shall comprise the following:

#### **Cover – 1 (Technical Bid)**

i. The Bid Documents duly filled and signed.

ii) List of Annexures

- a) Performance of the Bidder showing value of Civil Engineering work for the past Five years – (7.1.4) **Annexure - I**
- b) Average Annual Construction Turnover (Civil engineering work) for the last Five financial years – (7.1.5) **Annexure - II**
- c) Experience in works of similar nature and Magnitude within a period of 5 financial years – (7.1.6) **Annexure - III**
- d) Commitment of works on hand – (7.1.6) **Annexure - IV**
- e) Works for which Bid are already submitted – (7.1.6) **Annexure - V**
- f) List of Equipment available with Bidder – (7.1.7) **Annexure - VI**
- g) Qualification/Experience of key personnel proposed for technical and administrative functions under this contract – (7.1.8) **Annexure - VII**
- h) Sample Format for evidence of access to or availability of credit facilities – (7.1.9) **Annexure - VIII**
- i) Details of Litigation – (7.1.10) **Annexure - IX**

- j) Declaration by the bidder – (7.1.11) **Annexure - X**
- k) Details of components proposed to be sublet and sub-contractors involved – (7.1.12) **Annexure - XI**
- l) Technical staff to be employed (Para 10 of General Conditions) **Annexure - XII**

### iii. List of Certificates.

- a) Signature of the proprietor or proprietress attested by the Notary Public (2.2)
  - b) Signature of all the partners/power of attorney attested by the Notary Public – (2.3)
  - c) Registration of the firm, signature of the authorised person attested by the Notary Public – (2.4)
  - d) A copy of the listed power of attorney authorising the signatory of the bidder – (7.1.2)
  - e) Proof of registration of firm/Company (7.1.3)
  - f) Audited Balance Sheets – (7.1.5)
  - g) Credit line Certificate from Financial institutions – (7.1.9) (Format-VIII)
  - h) Income Tax Clearance Certificate – (7.1.13)
  - i) Sales Tax Verification Certificate – (7.1.14)
  - j) Certificate of performance issued by not less than the rank of Executive Engineer of the organization concerned/responsible person of the private organization – (7.3)
- iv) Bid Security
- v) Any other material required to be completed and submitted by the bidders in accordance with these instructions.

### Cover – II (Price Bid)

- 12.2 Priced Bill of Quantity duly signed.



12.3 The Bid should be submitted only in the original documents as issued by the Employer (or) as downloaded from the website. No alteration or correction should be made under any circumstances in the Bid Documents issued by the Employer (or) as downloaded from the website.

12.4 Conditional tenders are liable for rejection.

### **13. Bid Prices**

13.1 The contract shall be for the whole works as described in sub clause (1.1), based on the priced bill quantities submitted by the bidder.

13.2 The bidder shall fill in rates and prices and line item total (both in figures and words) for all items of works described in the Bill of quantities along with total bid price (both in figures and words). Items for which no rate or price is entered by the bidder will not be paid for by the employer when executed and shall be deemed covered by the other rates and prices in the bill of quantities. Corrections, if any, shall be made by crossing out, initialing,

13.3 All duties, taxes and other levies payable by the contractor, under the contract or for any other cause shall be included in the rates, prices and total bid price submitted by the bidder.

13.4 The rates and prices quoted by the bidder are subject to adjustment during the performance of the contract in accordance with the provisions of clause 51.

### **14. Currencies of Bid and Payment**

14.1 The unit rates and the prices shall be quoted by the bidder entirely in Indian Rupees.

### **15. Bid Validity**

15.1 Bids shall remain valid for a period not less than **one hundred and twenty days** from the date of opening of Technical Bid. A bid valid for a shorter period shall be rejected by the Employer as non-responsive.

15.2 In exceptional circumstances, prior to expiry of the original time limit, the Employer may request the bidders to extend the period of validity for a specific additional period. The request and the bidders' response shall be made in writing or by cable. A bidder may refuse the request without forfeiting his bid security. A bidder agreeing to the request will not be required or permitted to modify his bid, but will be required to extend his bid security for; the period of extension.

## 16. Bid Security

16.1 The bidder shall furnish, as part of his bid, as bid security of **Rs. 1.50 lakh (Rupees One lakhs and fifty thousand only)** duly pledged in favour of the **Project Engineer, P.M Unit, OWSSB, Cuttack.** in any one of the following forms Demand draft / Deposit call receipt / Fixed deposit receipt / Bank guarantee issued by any Nationalised Bank / Scheduled Bank located in India, National savings certificate, Post office Savings Bank deposits.

- Unconditional Bank Guarantee in the prescribed format for the bid security issued by a Nationalised Bank/Scheduled Bank located in India & valid for 45 days after the end of the validity period of the bid.

FDR and deposits at call receipts should contain lien certificate issued by the Bank for encashment by department. The FDR furnished by the firm should also bear the signature of the authorized signatory on a revenue stamp at the back of the FDR.

16.2 Any bid not accompanied by bid security in stipulated form shall be rejected by the Employer as non-responsive.

16.3 The bid security of the unsuccessful bidders will be returned as promptly as possible, but not later than 30 days either after the expiration of the period of bid validity or after finalisation of the bid whichever is later.

16.4 The bid security of the successful bidder will be returned after the bidder has furnished the required performance security and signed the agreement. No interest is payable on Bid security by the Employer.

16.5 The bid security shall be forfeited.

- In the case of bidder withdrawing or modifying his bid during the period of bid validity
- If the bidder does not accept the corrections of the bid price, pursuant to clause 28 of "Bid Opening and Evaluation"
- In the case of a successful bidder failing to furnish the performance security in the specified form within the stipulated time.
- In the case of successful bidder failing to enter into agreement within the stipulated time.
- In the case of the bidder severing the conditions after intimation of the acceptance of the bid.

## 17. Compliance to Technical Design and Specifications.

17.1 Bidders shall submit their offers that comply with the requirements of the bidding documents including the basic technical design as indicated in the drawing and specifications.

## 18. Format and Signing of Bid

- 18.1 The bid document submitted to the Employer shall be typed or written in indelible ink and shall be signed by a person duly authorised to sign on behalf of the bidder in accordance with "Instructions to Bidders". All pages of the bid and where entries or corrections have been made shall be initialed by the person signing the bid.
- 18.2 The bid shall contain no alteration or additions, except those to comply with the instructions issued by the Employer and wherever necessary to correct errors made by the bidder, in which case such corrections shall be initialed by the person signing the bid.
- 18.3 The technical and price bids (BOQ) as issued by the Employer should be submitted duly signed at the bottom of each page, failing which the bids will be summarily rejected.

## 19. Pre Bid Meeting:

### 19.1

The bidder or his authorised representative, who are desirous, may attend the pre bid meeting which will take place at **The Member Secretary, OWSSB on ..... at 11.00 AM.**

- 19.2 The purpose of the meeting will be to clarify issues and to answer questions on any matter than may be raised at that stage.
- 19.3 The bidder is requested, as far as possible, to submit the questions in writing or by cable, to reach the Employer not later than one week before the meeting. It may not be practicable at the meeting to answer questions received late.
- 19.4 Minutes of the meeting, including the text of the questions (without Identifying the source of enquiry) and the responses given together with any responses prepared after the meeting, will be transmitted without delay to all purchasers of the bidding documents. Any modification of the bidding documents listed in clause 23.1 of "Submission of Bids", which may become necessary as a result of the pre bid meeting shall be made by the Employer exclusively through the issue of an addendum pursuant to clause 10 of the "Bid Document" and not through the minutes of the pre bid meeting. Then will be hosted on [www.odisha.gov.in](http://www.odisha.gov.in)
- 19.5 Attendance at the pre bid meeting is not mandatory and non-attendance will not be a cause for disqualification of the bidder.

## **E. SUBMISSION OF BIDS**

### **20. Sealing and Marking of Bids**

- 20.1 Two cover system shall be adopted for submission of bids.
- 20.2 The first cover shall contain the technical bid documents, supporting material relating to the eligibility criteria, Bid Security in the proper form and other connected Certificates.
- 20.3 No indication direct or indirect, implicit or explicit regarding the rates and prices should be made in the technical bid or any other documents submitted in the first cover.
- 20.4 The second cover shall contain the Price Bid alone.
- 20.5 The bids should be submitted in the original bid documents as issued by the Employer.
- 20.6 The bid documents, under no circumstances, are transferable.
- 20.7 The first cover containing the Technical Bid and Bid Security and the second cover containing the Price Bid, should be pasted properly, sealed and super scribed indicating clearly the name of work and marking specifically as under:

#### **Cover I - Technical Bid**

#### **Cover II - Price Bid**

Both the covers containing the Technical bid and Price Bid should be placed in a common envelope, pasted, sealed and superscribed properly.

### **20.8 Format and signing of Tender**

- 20.8.1 The Bidder shall submit one original and one copy (Hard) and one soft copy of technical bids comprising of Tender as described in the Instruction to Bidders, bound in a format as stipulated.
- 20.8.2 All bidders will be provided with an electronic copy of the schedule of prices. Cells that contain permanent information and are not to be changed by the Bidder will be protected.
- 20.8.3 Cells into which the bidder can enter rates and Amount (where these may vary), will be left unprotected. However, the Employer will not enter any formulae in the spread sheets.
- 20.8.4 The Bidder is entirely responsible to ensure that the calculations presented in the Schedule of Prices are correct, and that the Bidders offer is complete in all respects. The Price Bid completed in computerized printout, adopting the format of the Bid document in total and shall be signed by a person or persons duly authorized to sign on behalf of the Bidder.

- 20.8.5 The Bidder will need to submit the completed Schedule of Prices together with the bound copy of the Price Proposal which has been issued by the Employer along with the separate Priced Schedule of Prices, and to affix his signature on all pages of his submittal. The Bidder shall give an undertaking that the content of the CD and the content of hard copies are identical. In the case of discrepancy between the soft copy and hard copy (print out) furnished by the bidder, the hard copy (print out) will prevail. If there is discrepancy between the hard/soft copy furnished by the bidder and the hard copy issued by the Employer, the hard copy issued by the Employer will prevail.
- 20.8.6 The Tender shall contain no alternations, omissions or additions, except those to comply with instructions issued by the Employer, or as necessary to correct errors made by the Bidder, in which case such corrections shall be initialed by the person or persons signing the Tender.
- 20.8.7 All the envelopes shall be addressed to the Employer **the Member Secretary, OWSSB**, and bear the following identification.

**Bid for**

Construction of Septage treatment Plant in Sambalpur Town in Sambalpur District, Odisha - Construction of Settling-thickening tanks, Sludge drying beds, Anaerobic Baffled Reactors, Horizontal planted gravel filter, Maturation pond, Filtrate sump, Security room, CC pavement, construction of compound wall around the treatment plant, Effluent disposal arrangement, Construction of Pump Room of 12 m<sup>2</sup>, supply, delivery and installation of Non clog submersible pump sets, laboratory room, watch shed, administrative room etc. complete including Trial run for 3 Months (period of completion - 9 months )

**IFB NO. .... / SeTP/2016.**

Do Not Open Before ..... **at 4.00 PM** (Time and date of bid opening as per Clause 24 of "Bid Opening and Evaluation") and should be submitted to the following address.

**The Member Secretary,  
OWSSB, SATYA NAGAR,  
Bhubaneswar – 751 007.**

- 20.9 In addition to the Identification required in sub clause above, the envelope shall indicate the name and address of the bidder to enable the bid to be returned in case it is declared late, pursuant to Clause 22 of "Submission of Bids".
- 20.10 If the envelope is not sealed and marked as above, the Employer will assume no responsibility for the misplacement or premature opening of the bid.

**21. Deadline for Submission of the Bids**

- 21.1 Bids must be received by the Employer at the address specified in clause 20.8 above not later than ..... **P.M. on .....** In the event of the specified date for the submission of bids declared a holiday for the Employer, the bids will be received up to the appointed time on the next working day.

- 21.2 The Employer may extend the deadline for the submission of bids by issuing amendment in accordance with clause-10 of "Bid Document" in which case all rights and obligations of the Employer and the bidders previously subject to the original deadline will then be subject to the new deadline.

## **22. Late Bids**

- 22.1 All bids received by the Employer after the deadline prescribed in clause 21 of "Submission of Bid" will be returned unopened to the bidder.

## **23. Modification, Substitution and Withdrawal of Bids**

- 23.1 The bidder may modify, substitute or withdraw his bid after submission, provided that written notice of the modification, substitution and withdrawal is received by the Employer prior to the deadline for submission of bid.
- 23.2** The bidder's modification, substitution or withdrawal notice shall be prepared, sealed, marked and delivered in accordance with provisions of clause 20 and 21 of "Submission of Bid", with the envelope additionally marked '**MODIFICATION**', '**SUBSTITUTION**' or '**WITHDRAWAL**' as appropriate. The modification / substitution for price bid cover should be super scribed as **PRICE 'MODIFICATION' / SUBSTITUTION COVER**.
- 23.3 No bid shall be modified, substituted or withdrawn after the deadline for submission of bids.
- 23.4 Modification, substitution or withdrawal of a bid between the deadline for submission of bids and the expiration of the original period of validity specified in clause 15.1 of "Preparation of Bids" or as amended pursuant to clause 15.2 of "Preparation of Bids" may result in the forfeiture of the Bid Security pursuant to Clause 16 of "Preparation of Bids".

## **F. BID OPENING AND EVALUATION**

### **24. Bid Opening**

- 24.1 The Employer will open all the bids received (except those received late) including modifications made pursuant to clause 23 of "Submission of Bids", in the presence of the bidders or their representatives who choose to attend on the date at the time in the address specified in clause 20 of "Submission of Bids".(In the event of specified date of bid opening being declared a holiday for the Employer, the bids will be opened at the appointed time and location on the next working day).
- 24.2 Envelopes marked "withdrawal", "substitution" and "modification" shall be opened and read out first. Bids for which an acceptable notice of withdrawal has been submitted pursuant to clause 23 of "Submission of Bids" shall not be opened. Envelopes super scribed as '**MODIFICATION**' / **SUBSTITUTION to price bid will be opened at the time of opening of the price bid.**
- 24.3 The Bidders' names, the Bid prices, the total amount of each Bid, any discounts, bid modification, (substitution) and withdrawals, the presence or absence of Bid Security and such other details as the Employer may consider appropriate, will be announced by the Employer at the opening. Bids (and modifications) sent pursuant to clause 22 of "Submission of Bids" that are not opened and read out at the bid opening will not be considered for further evaluation regardless of the circumstances. Withdrawn bids will be returned unopened to the bidders.

### **25. Process to be Confidential**

- 25.1 Information relating to the examination, clarification, evaluation and comparison of bids and recommendations for the award of a contract shall not be disclosed to bidders or any other person not officially concerned with such process until the award to the successful Bidder has been announced. Any effort by a bidder to influence the Employer's processing of Bids or award decisions may result in the rejection of his bid.

### **26. Clarification of Bids.**

- 26.1 To assist in the examination, evaluation and comparison of bids, the Employer may, at his discretion, ask any Bidder for clarification of his bid, including breakdown of unit rates. The request for clarification and the response shall be in writing or by cable, but no change in the price or substance of the Bid shall be sought, offered, or permitted except as required to confirm the correction of arithmetic errors discovered by the Employer in the evaluation of the Bids in accordance with Clause 28 of "Bid Opening and Evaluation".

### **27. Examination of Bids and Determination of Responsiveness**

- 27.1 Prior to detailed evaluation of Bids, the Employer will determine whether each Bid
- (a) meets the eligibility criteria set out in clause (7);
  - (b) has been properly signed,
  - (c) is accompanied by the required securities and
  - (d) is substantially responsive to the requirements of the Bid Documents,

27.2 A substantially responsive Bid is one which conforms to all the terms, conditions and specifications of the Bid Documents, without material deviation or reservation. A material deviation or reservation is one (a) which affects in any substantial way the scope, quality or performance of the works. (b) which limits in any substantial way, inconsistent with the Bid Documents, the Employer's rights to the Bidder's obligations under the contract, or (c) whose rectification would affect unfairly the competitive position of other bidders presenting substantially responsive Bids.

27.3 If a Bid is not substantially responsive, it will be rejected by the Employer, and may not subsequently be made responsive by correction or withdrawal of the non-conforming deviation or reservation. The decision of the Employer on the issue whether the Bid is responsive or not" will be final and binding on the bidders. The Employer is not bound to disclose the reason in case a bid is determined by him as non-responsive.

## **28. Correction of Errors**

28.1 Bids determined to be substantially responsive will be checked by the Employer for any arithmetic error. Errors will be corrected by the Employer as follows:

- If any variation in the rates in words and figures, the lesser of the two will only be taken into consideration.
- Where there is a discrepancy between the unit rate and line item total resulting from multiplying the unit rate by the quantity, the unit rate as quoted will govern.
- Where there is an arithmetical discrepancy in the page total as well as grand total, the corrected total by the Employer will govern

28.2 The amount stated in the Bid will be adjusted by the Employer in accordance with the above procedure for the correction of errors and shall be considered as binding upon the Bidder. If the Bidder does not accept the corrected amount of the Bid, his bid will be rejected and his bid security may be forfeited in accordance with Clause 16.5 of "Preparation of Bids".

## **29. Evaluation and Comparison of Bids.**

29.1 The Employer will evaluate and compare only the Bids determined to be substantially responsive in accordance with Clause 27 of "Bid Opening and Evaluation".

29.2 In evaluating the Bids, the Employer will determine for each Bid the evaluated Bid Price by adjusting the Bid price as follows:

- Making any correction for errors pursuant to Clause 28 of "Bid Opening and Evaluation". or
- making appropriate adjustments to reflect discounts or other price modifications offered in accordance with Clause 23 of "Submission of Bids"

### **29.3 The Employer reserves the right to accept or reject any variation/deviation.**

29.4. If the Bid of a successful Bidder is seriously unbalanced in relation to the Engineer's estimate of the cost of work to be performed under the contract, the Employee may require the Bidder to produce detailed price analysis for any or all items of the Bill of Quantities to demonstrate the internal consistency of those prices with the construction methods and schedule proposed.



After evaluation of the price analysis, the Employer may require that the amount of the Performance Security set forth in Clause 34 of; "Award of Contract" be increased at the expense of the successful Bidder to a level sufficient to protect the Employer against financial loss in the event of default of the successful Bidder under the Contract.

For tenders received with 5 to 15% less than the departmental value the successful tender should remit additionally 2% towards security deposit on departmental value.

For tenders received with beyond 15% less than the departmental value, the successful Bidder should remit 50% of the difference between the departmental value and the value of tender as additional security deposit.

## G. AWARD OF CONTRACT

### 30. Award Criteria.

- 30.1 Subject to Clause 29 of "Bid Opening and Evaluation", the Employer will award the contract to the Bidder, whose Bid has been determined to be substantially responsive to the Bid Documents and who has offered the lowest evaluated Bid Price, provided that such Bidder has been determined to be (a) eligible in accordance with the provision of clause 6 of "Eligibility/Qualification Criteria" and (b) qualified in accordance with the provisions of Clause 7 of "Eligibility / Qualification Criteria".

### 31. Employer's Right to Accept any Bid and to Reject any or all Bids

- 31.1 The Employer reserves the right to accept or reject any bid, and to annul the bidding process and reject all bids, at any time prior to award of contract, without thereby incurring any liability to the affected bidder or bidders or any obligation to inform the affected bidder or bidders of the grounds for the Employer's action.

### 32. Notification of Award

- 32.1 The Bidder whose Bid has been accepted will be notified of the award by the Employer prior to expiration of the Bid validity period by cable, telex or facsimile confirmed by registered letter. This letter (hereinafter and in the Conditions of Contract called the "Letter of Acceptance"), will state the sum that the Employer will pay to the contractor in consideration of the execution, completion and maintenance of the works by the Contractor as prescribed by the Contract (hereinafter and in the conditions of Contract called the "Contract Price")

- 32.2 The notification of award will constitute the formation of the Contract.

### 33. Registration in Govt. of Odisha

- 33.1 The successful contractor/firm, if not a registered contractor in Odisha Supply and Drainage Board, he / they shall get himself / themselves registered in .....

### 34. Performance Security

- 34.1 A) Within 28 days from the date of the Letter of Acceptance, the successful bidder shall deliver to the Employer a Performance Security

- i) in the form of National Savings Certificate / Post Office Savings Deposit account purchased within the State of Odisha and pledged in favour of the **Project Engineer, PMU, OWSSB, Cuttack.**

(OR)

- ii) Unconditional and irrevocable bank guarantee issued by any one of the branches of Nationalised Bank or scheduled Bank within the State of Odisha, provided they are in prescribed format (enclosed in this Document) for an amount equivalent to 5% of the total value of the contract in favour of the **Project Engineer, PMU, OWSSB, Cuttack.**

**34.2** The bidder along with the performance security shall deliver a non-judicial stamp paper for Rs.100/- (Rupees hundred only) at his cost for executing the agreement.

**35. Signing of Agreement**

35.1 The Employer on receipt of the performance security and non-judicial stamp paper, will furnish to the bidder the Agreement in the form prescribed, incorporating all terms and conditions between the Employer and the successful bidder.

35.2 The Bidder should remit the performance security prescribed by the Employer in the form as in Clause 34 above and sign the agreement in the presence of the Employer within 28 days from the date of Letter of Acceptance notifying the award of contract.

35.3 Upon furnishing the performance security by the successful bidder, the Employer will promptly notify the other bidders that their bids have been unsuccessful.

35.4 Failure of the successful bidder to comply with the requirements of Clause 34 & 35 and 35.2 of "Award of Contract" shall constitute a breach of contract, cause for annulment of the award, forfeiture of the bid security and any such other remedy the Employer may take under the contract

**Amendment to Agreement**

35.5 Any amendment shall be issued by mutual consent between the Employer and the contractor only without any contrary to the bid conditions.

**36. Mobilisation Advance**

**Mobilisation advance not allowed.**

**37. Forfeiture of Performance Security**

37.1 The performance security is liable to be forfeited in cases where the firm/contractor fails to carry out the work in accordance with the specifications, terms and conditions of the contract leading to termination of the contract.

#### **IV- PROGRAMME SCHEDULE**

### **38. Project completion and Financial Milestone**

- 38.1 The twenty eighth day from the date of issue of work order shall be reckoned as the start date of the contract period.
- 38.2 Entire project must be completed in all respects within **Nine months** for construction work and Three months for trial run, successful commissioning & proof of guarantee performance.
- 38.3 The milestone for each component would be as under:

| Sl. No. | Description                            | % of achievement | Cumulative % of achievement |
|---------|--|------------------|-----------------------------|
| 1.      | Up to I Quarter (3 Months)             | 40 %             | 40 %                        |
| 2.      | Up to II Quarter (6 months)            | 30 %             | 70 %                        |
| 3.      | Up to III Quarter (9 months)           | 30 %             | 100%                        |
| 4.      | After completion of work –<br>3 Months |                  | Trial run                   |

### **39. Programme Schedule / Rate of Progress / Milestone**

39.1 The Contractor, within seven days from the date of signing of the agreement shall submit to the Engineer for approval **an Activity Chart showing the general methods, arrangements, order and timing for all the activities in the Works.**

39.2 An update of the Activity Chart shall be a Programme showing the actual physical progress achieved on each activity and the progress to be achieved on the remaining work including any changes to the sequence of activities. The Contractor shall submit to the Engineer in charge, for approval, an updated Activity Chart. The Employer reserves the right to approve or reject the updated Activity Chart without prejudice to levying of liquidated damages for slow progress.

### **40. Penalty for Defective Construction**

If any defect is noticed by the Employer in the construction of any portion of work/component, the Employer shall levy penalty up to 10% of the total value of the defective work as assessed by the Engineer in charge, in addition to rectification of defective works at his cost.

### **41. Liquidated damages**

41.1 Provided the firm/contractor fails to maintain the required rate of progress/mile stones liquidated damages will be invoked at the rate of 0.05% per week for the unfinished work. The firm/ contractor achieve the next mile stone within the stipulated period cumulatively

(i.e. including the first mile stone) the levied Liquidated Damages will be revoked. The amount recoverable towards liquidated damages shall however be restricted to 10% of the total contract value. The imposition of the liquidated damages clause will be without prejudice to the rights of the Employer to terminate the contract as time barred.

41.2 For imposing liquidated damages, detailed show cause notice shall be served on the defaulting firm/contractor either by RPAD or through personal service. The first notice shall be served allowing 15 days' time to the firm/contractor for furnishing the reply by them. In case of non-receipt of reply on expiry of 15 days' time from the date of first notice, the second notice shall be served allowing 7 days of time to the firm/contractor for furnishing the reply by them. Again in case of non-receipt of reply on expiry of 7 days' time from the date of second notice, the third notice shall be served allowing 3 days of time to the firm/contractor for furnishing the reply by them. On receipt of the reply, it shall be verified by the Engineer in charge and liquidated damages clause shall be invoked by issuing an explicit speaking order to the firm/ contractor, Similarly, the non-receipt of any reply from the firm/ contractor shall attract imposing the liquidated damages clause automatically and in this case also, the liquidated damages shall be imposed by issuing an explicit speaking order to the firm/contractor.

#### **42. Foreclosure of Works**

The Employer shall have the right to issue notice to the firm/contractor, for any reason whatsoever does not require the whole or part of the works to be carried out after the award of the contract. The contractor shall not have any claim towards compensation or whatsoever, on account of any profit or advantage, which he might have derived from the execution of such works. For the works executed which could not be utilised in view of the foreclosure, the firm/contractor shall be paid a eligible amount as certified by the Engineer in charge.

## V- PAYMENTS AND RECOVERIES

### 43. Payment Schedule

Payment shall be made in stages for each component as envisaged under:

#### CIVIL WORKS:

95% of the measured and check measured quantity

2.50% on commissioning of the scheme

2.50% on completion of the Trial run period

#### PUMPING MAIN, BOOSTER MAIN FEEDER MAIN, GRAVITY MAIN AND D'SYSTEM

##### 1. For Pipes & allied works

|   |        |
|---|--------|
| After supply at site  | - 75%  |
| After laying, jointing and testing of pipe  | - 85%  |
| After satisfactory completion of trial run & after commissioning of the entire length of main | - 95%  |
| After completion of full Trial run period of the scheme as a whole                            | - 100% |

##### 2. Mechanical items in pumping & treatment plant

|                                      |        |
|--------------------------------------|--------|
| After receipt of materials at site   | - 75%  |
| After erection                       | - 90%  |
| After commissioning                  | - 95%  |
| After completion of Trial run period | - 100% |

**Trial run Period:**

Trial run of the scheme – **3 months at Free of Cost.**

**Note:**

- The percentage of payment mentioned above are with reference to the total value of each component as per the agreement entered into by the firm/contractor except pumping main and distribution system.
- The payment shall be made for each component as per the actual measurement up to the percentages mentioned above for the stage of progress of each component. In the case of actual value of works carried out becoming lesser than the percentage limits prescribed for the stages, the payments shall be restricted to the actuals.
- 5% of the value of every running bill shall be retained by the Employer as additional performance security.
- Payments shall become eligible only for finished items of works in all respects.

**43.1 Preparation of bills:**

The Contractors will submit their bills every month in the M. Book format for the Quantity only of the relevant running bill duly signed. This will be treated as claim of the Contractor to consider payment every month.

The Contractor shall submit their bills to the Executive Engineer or any of his subordinate officer under his control as directed by the Executive Engineer. The Executive Engineer shall be responsible to scrutinize and make payment to the Contractor within 6 weeks from the date of submission of bills by the Contractor concerned.

**44. Release of Performance Security & Retention Amount**

- 44.1 In addition to the withheld amount, 40% of the amount of each bill of the contract shall be deducted and will be retained till the date of receipt of certificate of water tightness from the **Project Engineer, PMU, OWSSB, Cuttack**. The whole of the above sum of together with any recovery from the payments already made to the contractor as may be assessed by Project Engineer, PMU, OWSSB, Cuttack shall be forfeited to the OWSSB if the RCC reservoir develops structural defects or leaks. The above recovery shall be exclusive of the amount deposited towards security deposit. The fact of carrying out water tightness test should be recorded in the M. Book. The last part bill should be passed only after above certificate is issued. However, the contractor shall be permitted to execute an indemnity bond/BG in lieu of the recovery of 40% in each bill in prescribed form in non-judicial stamp paper for a value of Rs.100.00 towards water tightness and structural stability of the reservoir/water retaining structure. The period of guarantee required by the contract shall be two years from the date of completion

and commissioning (with filling of water up to maximum water level in the case of service reservoir/overhead tanks/water retaining structure). If defects are noticed within the stipulated period of **24 months** of satisfactory performance, the defects should be rectified by the contractor at his own cost and the performance period again shall be reckoned from the date of completion of the rectification of defects by the contractor. In the case of service reservoir/overhead tanks and other water retaining structures during this period, structure under full working head of water should show no sign of leakage. The test for water tightness should be arranged to be carried out and completed within 30 days from the date of intimation by the Engineer in charge. The testing of the service reservoir/overhead tank and other water retaining structures should be done by the contractor at his own cost inclusive of all necessary equipment, water etc., complete. The test for water tightness of the structure as well as materials of construction used shall be conducted in conformity with the standard specifications as per I.S. 3370 (Part-I) – 2009 as amended from time to time and the other specifications as mentioned in the Bid Document.

- 44.2 The security deposit less any amount due to the Board and 2 ½ % out of the total 5% of the retention amount made in every running bill shall be released in final bill which shall be prepared after the works are completed in all respects and after completion of Trial run period.
- 44.3 In respect of building works, RCC reservoir and other works where water tightness and soundness are to be observed for more than six months notwithstanding above clause, the balance 2 ½ % out of the total 5% retention amount from final bill in respect of contract for original construction or original building works, construction of RCC reservoir etc., will be retained by Engineer-in-Charge and paid to the contractor after a period of 24 months of satisfactory performance of entire civil works including trial period and on production of irrevocable Bank Guarantee in a prescribed form for the above amount to ensure structural stability.

#### **45. Recovery of money payable to OWSSB**

- 45.1 All losses, costs, damages and expenses and other money payable to the Board by the contractor under any stipulation in the contract, may be retained out of any money due or which may subsequently become due from the Board to the contractor under any contract or otherwise whatsoever and in case such money then due or to become due to the contractor by the Board shall be insufficient to pay such losses, costs, damages, and other money payable to the Board by the contractor, it shall be lawful for the Engineer in charge without any further consent on the part of the contractor to sell notes for the securities deposited in the Board by the contractor as aforesaid and with and out of the proceeds of such sale, after payment of all expenses connected therewith or reimburse and pay to the Board all such losses, cost, damages and expenses and other money payable to the contractor. And in case such proceeds of sale of the said securities shall be insufficient for such purpose



then and in that case it shall be lawful for the Board to recover the residue thereof, if necessary by legal proceedings and or by resorting to revenue recovery act against the contractor.

#### **46. Income Tax**

46.1 During the course of the contract period, deduction of income tax shall be made at the prevailing rates from every payment as may be specified by the Income Tax Department and as amended time to time.

#### **47. Sales Tax**

47.1. From every payment made to the firm/ contractor, deduction at source towards tax shall be made for civil works contract (presently at 2%) and for all other works contract (presently at 5%) subject to issue of amendments from time to time by Odisha Commercial Tax Department.

#### **48. Excise Duty & Service Tax.**

##### **48. a. Excise Duty.**

**All rates are inclusive of Excise Duty.**

Excise duty is applicable in Water Supply Schemes wherever necessary as prescribed in Notification No. 12/2012 – Central Excise, Dated: 17.03.2012. Subject to the issue of amendments from time to time by GOI, Ministry of Finance, Department of Revenue, New Delhi.

##### **b. Service Tax.**

Service taxes applicable wherever necessary as per Notification No: 25/ 2012 – Service tax, dated: 20.06.2012 subject to issue of amendments from time to time by GOI, Ministry of Finance, Department of Revenue, New Delhi.

#### **49. BUILDING AND CONSTRUCTION WORKERS WELFARE CESS**

Towards contribution of fund for the benefit of manual workers employed in the construction works an amount equivalent to one percent of total estimated cost of the construction work proposed will be paid by the Employer direct to the respective welfare Board, subject to issue of amendments from time to time by the respective department of Government of Odisha.

*(Lump sum provision for this contribution may be appropriately made in the Estimates sanctioned for the schemes and the amount would be remitted at the end of the financial year to the labour welfare Board)*

## 50. Price Adjustment:-

### 50.1 The conditions for price adjustment shall be as follows.

**Price Variation / Escalation Clause:** (Vide Works Deptt. Office Memorandum No.12606/W dt.24.12.2012)

Contract price shall be adjusted for increase or decrease in rates and price of Labour, Cement, Steel, Bitumen, Pipes, POL & other material component in accordance with the following principles and procedures as per formula given below:-

#### **i) - REIMBURSEMENT / RECOVERY DUE TO VARIATION IN PRICES OF MATERIALS OTHER THAN (STEEL, CEMENT, BITUMEN, PIPES & P.O.L.)**

If during the progress of the work, the price of any material (excluding the cost of Steel, Cement, Bitumen & P.O.L) incorporated in the work (not being materials supplied from the Engineer-in-charge's store) in accordance with Clause thereof increases or decreases as a result of increase or decrease in the average wholesale price index (all commodities), and the contractor thereupon necessarily and properly pays in respect of that material (incorporated in the work) such increased or decreased price, then he shall be entitled to reimbursement or liable to refund, quarterly as the case may be, such an amount as shall be equivalent to the plus or minus difference of 85% in between the average wholesale price index (all commodities) which is operating for the quarter under consideration and that operated for the quarter in which the bid was received (last date of receipt) as per the formula indicated below provided that the work has been carried out within the stipulated time or extension thereof as are not attributable to him. If penalty is levied for delayed completion of the work, the contractor shall not be eligible to get price escalation on the above materials on the value of works executed during the extended period.

The clause will be applicable to the contracts where original stipulated period of completion is more than 18 months.

In the situation where the period of completion is initially stipulated in the agreement as less than 18 (eighteen) months but subsequently the completion period has been validly extended on the ground that the delay in completion is not attributable to the contractor and in the result the total period including the extended period stands more than 18(eighteen) months or more, price escalation for other materials is admissible only for the remaining period excluding 18(eighteen) months there from.

Formula to calculate the increase or decrease in the price of materials:

Price adjustment for increase or decrease in cost of materials other than cement, steel, bitumen, pipes and POL procured by the contractor shall be paid in accordance with the following formula.

$$V_m = 0.85 \times P_m = 100 \times R \times (M_i - M_0) / M_0$$

$V_m$  = Increase or decrease in the cost of work during the quarter under consideration due to changes to rates of materials other than cement, steel, bitumen, pipes and POL.

R= Value of work done during the quarter under consideration excluding the work executed under extra items if any at prevailing schedule of rate / derived rates.

$M_0$  = The all India wholesale price index (all commodities) prevailed during the quarter of last date of receipt of bids (as published by the Economic Adviser to Govt. of India, Ministry of Industry and commerce, New Delhi)

$M_i$  = The all India wholesale price index (all commodities) for the quarter under consideration as published by Economic Advisor, govt. of India, Ministry of Industry and commerce, New Delhi. In respect of the justified period extended for completion of the work, the index prevailing at the time of stipulated date of completion or the prevailing index of the period under consideration, whichever is less, shall be considered.

$P_m$  = Percentage of material component (other than cement, steel, bitumen, pipes and POL) of the work, as indicated in clause – 3.19(d) below.

**ii) REIMBURSEMENT / RECOVERY OF DIFFERENTIAL COST DUE TO VARIATION IN PRICES OF PRINCIPAL MATERIALS (STEEL, CEMENT, BITUMEN AND PIPES NOT ISSUED BY DEPARTMENT) AFTER SUBMISSION OF TENDER.**

If after submission of the tender, the prices of Steel , Cement, Bitumen and Pipes ( not being supplied by the Department ) increases / decreases beyond the price (s) prevailing at the time of the last date for submission of tenders including extension for the work, the contractor shall be eligible to get differential cost due to such hike on the value of works execute during the stipulated period and during the extended period when the reason of delay in completion of the work is not attributable to the contractor, If penalty is levied for delayed completion of the work, the contractor shall not be eligible to get price variation on the above materials on the value of works executed during the extended period.

Reimbursement in case of differential cost due to increase in prices of cement, steel, bitumen and pipes are to be made by the Project Engineer with prior approval of tender accepting authority subject to following conditions;

- 1) Contractors have to submit the vouchers showing procurement of different materials from authorized dealers for the said work.
- 2) Differential cost will be allowed only for the works which are progressed as per the approved work programme / revised work programme duly approved by the Engineer in charge.

Recovery in case of decrease in prices of cement, steel, bitumen and pipes shall be made by concerned Project Engineer for the contractor immediately.

The increase/decrease in prices of cement, steel, Bitumen and Pipes for reimbursement / recovery shall be determined as follow.

**a) Adjustment towards differential cost of cement.**

$V_c = (C_i - C_0)/C_0 \times$  Actual quantity of cement utilize in the work during the quarter under consideration  $\times$  base price of cement as prevailing on the last stipulated date of receipt of tender including extension, if any.

$V_c$  = Differential cost of cement i.e. amount of increase or decrease in rupees to be paid or recovered.

$C_i$  = All India Wholesale price index for cement for the quarter under consideration as published by Economic Adviser, Govt. of India, Ministry of Industry and commerce, New Delhi.

$C_0$  = All India Wholesale price index (as published by Economic Adviser, Govt. of India, Ministry of Industry and commerce, New Delhi ) for cement as prevailing on the last stipulated date of receipt of tender.

**b) Adjustment towards differential cost of Steel**

$V_s = (S_i - S_0) \times$  Actual quantity of steel utilized in the work during the quarter under consideration.

$V_s$  = Differential cost of Steel i.e. amount of increase or decrease in rupees to be paid or recovered.

$S_i$  = cost of the Steel as prevailed during the period under consideration as fixed by Steel authority of India.

$S_0$  = Base price of Steel prevailing as on the last date of submission of tender including extension, if any.

**c) Adjustment towards differential cost of Bitumen.**

$V_b = (B_i - B_0) \times$  Actual quantity of Bitumen utilized in the work during the quarter under consideration.

$V_b$  = Different cost of Bitumen i.e. amount of increase decrease in rupees to be paid or recovered.

$B_i$  = Average cost of Bitumen prevailed during the period under consideration as fixed by IOCL/BPCL/HPCL.

$B_0$  = Base price of bitumen as prevailing on the last stipulated date of receipt of tender including extension, if any.

**d) Adjustment towards differential cost of pipes.**

$$V = 0.85P_p / 100 \times R(P_i - P_0)/P_0$$

$V_p$  = Differential cost of pipe i.e. amount of increase or decrease in rupees to be paid or recovered during the quarter under consideration.

$P_p$  = Percentage of pipe component of the work as indicated in the clause 3.19(d) .

$R$  = Value of work done during the quarter under consideration excluding the value of work executed under extra items, if any, at prevailing schedule of rates or derived rate.

$P_i$  = All India Wholesale price index for the period under consideration as published by Economic Advisor, Govt. of India, Ministry of Industry and Commerce, New Delhi, for the type of pipe under consideration.

$P_0$  = All India Wholesale Price Index (as published by Economic Advisor, Govt. of India, Ministry of Industry and Commerce, New Delhi) as on the last stipulated date of receipt of tender including extension, if any, for the type of pipe under consideration.

## 50.2 REIMBURSEMENT / REFUND DUE TO STATUTORY RISE IN COST OF MINIMUM WAGES BY GOVERNMENT.

If after submission of the tender, the wages of labour increases or decreases as a direct result of the coming into force of any fresh law, or statutory rule or order beyond the wages prevailing at the time of the last date of submission of tenders including extensions, the contractor shall be eligible to get escalation due to such hike on the value of works executed during the stipulated period and during the validly extended period when the delay in completion is not attributable to the Contractor. If penalty is levied for delayed completion of the work, the contractor shall not be eligible to get escalation on labour on the value of works executed during the extended period.

The contractor shall within a reasonable time of his becoming aware of any alteration in the price of any such wages of labour, give notice thereof to the Engineer-in-charge stating that the same is given pursuant to this condition together with all information relating thereto which he may be in a position to supply. Engineer-in-Charge may call books of account and other relevant documents from the contractor to satisfy himself about reasonability of increase in prices of

wages and actual payment thereof For this purpose, the labour component of the work execute during period under consideration shall be the percentage ( as specified in table below ) of the value of work done during that period and the increase / decrease in labour shall be considered on the cost of minimum daily wages of any unskilled labourers, fixed by the Government of Odisha under minimum wages act.

**The compensation for escalation for labour shall be work out as per the formula given below.**

$$V_i = 0.85 \times P_i / 100 \times R \times (L_i - L_0) / L_0$$

$V_i$  = Increase or decrease in the cost of work during the quarter under consideration due to changes in rates of maximum wages.

$R$  = Value of the work done during the quarter under consideration excluding the work executed under extra items if any at prevailing schedule of rate / derived rates.

$L_0$  = The minimum wages for labour as notified by State Govt. as prevailing on the last stipulated date of receipt of tender including extension, if any.

$L_i$  = The minimum wages for labour as notified by State Govt. & as prevailed on the last date of quarter previous to the one under consideration in respect of the justified period extended, the minimum wages prevailing on the last date of quarter previous to the quarter pertaining to stipulated date of completion or the minimum wage prevailing on the last date of the quarter previous to the one under consideration, whichever is less, shall be considered.)

$P_i$  = Percentage of labour component of the work, as indicated in the clause **3.19(d)**

### **REIMBURSEMENT/REFUND DUE TO VARIATION IN PRICES OF P.O.L.**

Similarly, if during the progress of work the prices of Diesel, Petrol, Oil and lubricants increases or decreases as a result of the price fixed thereof by the Government of India and the Contractor thereupon necessarily and properly pays such increased or decreased price towards Diesel, Petrol, Oil and Lubricants used in th execution of the work, then he shall be entitled to reimbursement or liable to refund, quarterly, as the case may be such an amount as shall be equivalent to the plus or minus difference of 85% in between the price of POL. Which is operating for the quarter under consideration and that operated for the quarter of last date of receipt of bids as per the formula indicated below provided

that the work has been carried out within the stipulated time or extension thereof as are not attributable to him. If penalty is levied for delayed completion of work the contractor shall not be eligible to get price escalation on POL on the value of works executed during the extended period.

**Formula to calculate the increase or decrease in the price of POL.**

$$V_i = 0.85 \times P_i / 100 \times R \times (F_i - F_0) / F_0$$

$V_i$  = Increase or decrease in the cost of work during the quarter under consideration due to Changes in rates for POL.

$P_i$  = Percentage of POL component of the work as indicated in clause – 19d below.

$R$  = Value of work done during the quarter under consideration excluding the work executed under extra items if any at prevailing schedule of rate / derived rates.

$F_i$  = All India Wholesale price index for Fuel, Oil & Lubricant (High Speed Diesel) for the quarter under consideration as published by Economic Adviser, govt. of India, Ministry of Industry and Commerce, New Delhi. In respect of the justified period extended, the rates prevailing at the time of stipulated date of completion or the prevailing rates of the period under consideration, whichever is less, shall be considered  $F_0$  = All India whole sale price index for fuel, oil and lubricant (High speed Diesel) as prevailing on the last stipulated date of receipt of tender including extension, if any.

The following percentages will give the price adjustment for the entire contract for different types of works as applicable given in the following table.

**Percentage Table**

| Sl. No. | Category of works                 |                                | % Component (cost wise)  |                         |  |
|---------|-----------------------------------|--------------------------------|--------------------------|-------------------------|--|
|         |                                   |                                | Labour (P <sub>l</sub> ) | P.O.L (P <sub>f</sub> ) | Steel + Cement+ Bitumen+ other materials * |
| 1.      | R&B works (% of component)        | Road works                     | 5                        | 5                       | 90   |
|         |                                   | Bridge works                   | 25                       | 5                       | 70   |
|         |                                   | Building works                 | 25                       | -                       | 75   |
| 2.      | Irrigation works (% of component) | Structural work                | 20                       | 5                       | 75   |
|         |                                   | Earth, Canal & Embankment work | 25                       | 10                      | 65   |
| 3.      | P.H. Work                         | Structural work                | 25                       | 5                       | 70   |
|         |                                   | Pipeline work                  | 5                        | -                       | <u>Pipe – 70%</u><br>* other material -25% |
|         |                                   | Sewer line                     | 10                       | -                       | <u>Pipe – 70%</u><br>* other material -20% |

\*Note: - Further break up may be worked out considering the consumption of cement, steel, Bitumen and pipe in the concerned works for the period under consideration.

**APPLICATION OF ESCALATION CLAUSE:**

(i) The contractor shall for the purpose of availing reimbursement / refund of differential cost of steel, bitumen, cement , pipe ,POL and wages, keep such books of account and other documents as are necessary to show that the amount of increase claimed or reduction available and shall allow inspection of the same by a duly authorized representative of Government and further, shall at the request of the Engineer-in-charge, furnish documents to be verified in such a manner as the Engineer-in-charge may require any document and information kept. The contractor shall within a reasonable time of 15 days of his becoming aware of any alteration in the price of such material, wages of labour and or price of POL give notice thereof to the Engineer-in-charge stating that the same is given pursuant to this condition along with information relating thereto which he may be in a position to supply.

ii) The compensation for escalation shall be worked out at quarterly intervals and shall be with respect to the cost of work done as per bills paid during the three calendar months of the said quarter. The first such payment shall be made at the end of three months after the month (excluding the month in which tender was accepted) and thereafter at three months' interval. At the time of completion of the work, the last period for payment might become less than 3 months, depending on the actual date of completion.

If at any time after the commencement of the work the Governor of Odisha shall for any reason whatsoever not require the whole thereof as specified in the tender to be carried out the Engineer-in-charge shall give notice in writing of the fact to the contractor who shall have no claim to any payment or compensation whatsoever on account of any profit or advantage, which he might have derived from execution of the work in full but which he did not derive in consequence of the full amount of the work not having been carried out, neither shall he have any claim for compensation by reason of any alterations having been made in the original specification, drawings, designs and instruction which shall involve any curtailment or increase of the work as originally contemplated.

**VI- LIST OF ANNEXURES**

| <b>No.</b> | <b>Description</b>  | <b>Para No.</b>               |
|------------|---|-------------------------------|
| I          | Performance of the Bidder showing value of Civil Engineering work for the past Five financial years               | 7.1.4                         |
| II         | Average Annual Construction Turnover  | 7.1.5                         |
| III        | Experience in works of similar nature and Magnitude within a period of Five years                                 | 7.1.6                         |
| IV         | Commitment of works on hand   | 7.1.6                         |
| V          | Works for which Bid already submitted   | 7.1.6                         |
| VI         | List of Equipment available with Bidder   | 7.1.7                         |
| VII        | Qualification/Experience of key personnel proposed for technical and administrative functions under this contract | 7.1.8                         |
| VIII       | Sample Format for evidence of access to or availability of credit facilities                                      | 7.1.9                         |
| IX         | Details of Litigation   | 7.1.10                        |
| X          | Declaration by the bidder   | 7.1.11                        |
| XI         | Details of components proposed to be sublet and Sub-contractors involved  | 7.1.12                        |
| XII        | Technical staff to be employed  | Para 10 of General Conditions |



**VI- LIST OF CERTIFICATES**

| <b>Sl. No.</b> | <b>Description of Certificate</b>   | <b>Para No.</b>          |
|----------------|---|--------------------------|
| 1              | Signature of the proprietor or proprietress attested by the Notary Public   | 2.2                      |
| 2              | Signature of all the partners/power of attorney attested by the Notary Public   | 2.3                      |
| 3              | Registration of the firm, signature of the authorised person attested by the Notary Public                                      | 2.4                      |
| 4              | A copy of the registered power of attorney authorising the signatory of the bidder  | 7.1.2                    |
| 5              | Proof of registration of firm/Company   | 7.1.3                    |
| 6              | Audited Balance Sheets  | 7.1.5                    |
| 7              | Credit line Certificate from Financial institutions   | 7.1.9<br>(Annexure-VIII) |
| 8              | Income Tax Clearance Certificate  | 7.1.13                   |
| 9              | Sales Tax Verification Certificate  | 7.1.14                   |
| 10             | Certificate of performance issued by not less than rank of Executive Engineer / Responsible person of the private organization. |                          |

**ANNEXURE I****PERFORMANCE OF THE BIDDER SHOWING TOTAL MONETARY VALUE OF CIVIL ENGINEERING WORKS IN THE LAST FIVE FINANCIAL YEARS**

| <b>Year</b> | <b>Monetary Value of Civil Engineering work (Rs. In lakhs)</b> |
|-------------|--|
| 2010 - 11   |  |
| 2011 -12    |  |
| 2012 – 13.  |  |
| 2013 – 14.  |  |
| 2014 – 15.  |  |

**Seal of the Firm****Signature of the bidder with date**

**ANNEXURE II**  
**ANNUAL CONSTRUCTION TURNOVER**

Each Bidder must fill in this form

| <b>Annual Turnover Data (Civil Engineering Works)<br/>in the last five Financial Years.</b> |             |                            |
|---|-------------|----------------------------|
| <b>Sl.<br/>No.</b>  | <b>Year</b> | <b>Amount<br/>Currency</b> |
| 1   | 2010 - 11   |                            |
| 2   | 2011 -12    |                            |
| 3   | 2012 – 13.  |                            |
| 4   | 2013 – 14.  |                            |
| 5   | 2014 – 15.  |                            |
| Average Annual Construction Turnover  |             |                            |

The information supplied should be the Annual Turnover of the Bidder in terms of the amounts billed to clients for each year for work in progress or completed.

Seal

.....  
.....

(Signature of the Bidder)

## ANNEXURE III

**EXPERIENCE IN WORKS OF SIMILAR NATURE AND MAGNITUDE WITH  
IN A PERIOD OF 5 YEARS. ( 2011-12 to 2015-16 )**

| Sl. No | Contract No. and Name of the Project | Description of the work | Name of the employer with full address | Value of the contract (Rs. In lakhs) | Date of Issue of work order and stipulated period of completion | Actual date of completion | Reason for the delay if any in completing the project |
|--------|--------------------------------------|-------------------------|--|--------------------------------------|---|---------------------------|---|
|        |                                      |                         |  |                                      |   |                           |   |
|        |                                      |                         |  |                                      |   |                           |   |
|        |                                      |                         |  |                                      |   |                           |   |
|        |                                      |                         |  |                                      |   |                           |   |
|        |                                      |                         |  |                                      |   |                           |   |
|        |                                      |                         |  |                                      |   |                           |   |
|        |                                      |                         |  |                                      |   |                           |   |
|        |                                      |                         |  |                                      |   |                           |   |
|        |                                      |                         |  |                                      |   |                           |   |
|        |                                      |                         |  |                                      |   |                           |   |
|        |                                      |                         |  |                                      |   |                           |   |
|        |                                      |                         |  |                                      |   |                           |   |
|        |                                      |                         |  |                                      |   |                           |   |
|        |                                      |                         |  |                                      |   |                           |   |
|        |                                      |                         |  |                                      |   |                           |   |

Seal of the firm

Signature of the bidder with date

**ANNEXURE IV****COMMITMENTS OF WORKS ON HAND**

| <b>Sl. No</b> | <b>Contract No and Name of the Project</b> | <b>Description of the work</b> | <b>Name of the employer with full address</b> | <b>Value of the contract (Rs. In lakhs)</b> | <b>Date of Issue of work order and stipulated period of completion</b> | <b>Value of works remaining to be completed (Rs. In lakhs)</b> | <b>Anticipated date of completion</b> |
|---------------|--|--------------------------------|---|---|--|--|---------------------------------------|
|               |  |                                |   |   |  |  |                                       |
|               |  |                                |   |   |  |  |                                       |
|               |  |                                |   |   |  |  |                                       |
|               |  |                                |   |   |  |  |                                       |
|               |  |                                |   |   |  |  |                                       |
|               |  |                                |   |   |  |  |                                       |
|               |  |                                |   |   |  |  |                                       |
|               |  |                                |   |   |  |  |                                       |
|               |  |                                |   |   |  |  |                                       |
|               |  |                                |   |   |  |  |                                       |
|               |  |                                |   |   |  |  |                                       |
|               |  |                                |   |   |  |  |                                       |
|               |  |                                |   |   |  |  |                                       |
|               |  |                                |   |   |  |  |                                       |
|               |  |                                |   |   |  |  |                                       |
|               |  |                                |   |   |  |  |                                       |
|               |  |                                |   |   |  |  |                                       |
|               |  |                                |   |   |  |  |                                       |
|               |  |                                |   |   |  |  |                                       |
|               |  |                                |   |   |  |  |                                       |
|               |  |                                |   |   |  |  |                                       |
|               |  |                                |   |   |  |  |                                       |
|               |  |                                |   |   |  |  |                                       |
|               |  |                                |   |   |  |  |                                       |
|               |  |                                |   |   |  |  |                                       |

Seal of the firm

Signature of the bidder with date

**ANNEXURE V****WORKS FOR WHICH BID ARE ALREADY SUBMITTED**

| Sl. No | Contract No and Name of the Project | Description of the work | Name of the employer with full address | Value of the contract (Rs. In lakhs) | Stipulated period of completion | Date when decision is expected | Remarks if any |
|--------|-------------------------------------|-------------------------|--|--------------------------------------|---------------------------------|--------------------------------|----------------|
|        |                                     |                         |  |                                      |                                 |                                |                |
|        |                                     |                         |  |                                      |                                 |                                |                |
|        |                                     |                         |  |                                      |                                 |                                |                |
|        |                                     |                         |  |                                      |                                 |                                |                |
|        |                                     |                         |  |                                      |                                 |                                |                |
|        |                                     |                         |  |                                      |                                 |                                |                |
|        |                                     |                         |  |                                      |                                 |                                |                |
|        |                                     |                         |  |                                      |                                 |                                |                |
|        |                                     |                         |  |                                      |                                 |                                |                |
|        |                                     |                         |  |                                      |                                 |                                |                |
|        |                                     |                         |  |                                      |                                 |                                |                |
|        |                                     |                         |  |                                      |                                 |                                |                |
|        |                                     |                         |  |                                      |                                 |                                |                |
|        |                                     |                         |  |                                      |                                 |                                |                |
|        |                                     |                         |  |                                      |                                 |                                |                |

Seal of the firm

Signature of the bidder with date

**ANNEXURE VI****LIST OF EQUIPMENT AVAILABLE WITH BIDDER**

| Sl. No | Equipment Name | Requirement for the project |          | Availability Status                    |                            |                       | Remarks |
|--------|----------------|-----------------------------|----------|--|----------------------------|-----------------------|---------|
|        |                | Nos                         | Capacity | owned/<br>leased/<br>To be<br>procured | Nos<br>and<br>capa<br>city | Age/<br>condit<br>ion |         |
|        |                |                             |          |  |                            |                       |         |
|        |                |                             |          |  |                            |                       |         |
|        |                |                             |          |  |                            |                       |         |
|        |                |                             |          |  |                            |                       |         |
|        |                |                             |          |  |                            |                       |         |
|        |                |                             |          |  |                            |                       |         |
|        |                |                             |          |  |                            |                       |         |
|        |                |                             |          |  |                            |                       |         |
|        |                |                             |          |  |                            |                       |         |
|        |                |                             |          |  |                            |                       |         |
|        |                |                             |          |  |                            |                       |         |

Seal of the firm

Signature of the bidder with date

**ANNEXURE VII****QUALIFICATION/EXPERIENCE OF KEY PERSONNEL PROPOSED FOR TECHNICAL  
AND ADMINISTRATIVE FUNCTIONS UNDER THIS CONTRACT**

| <b>Sl.<br/>No</b> | <b>Name of the<br/>person</b> | <b>Position<br/>for which<br/>proposed</b> | <b>Qualifi<br/>cation</b> | <b>Total Years<br/>of<br/>experience</b> | <b>Years of<br/>experience<br/>in the<br/>proposed<br/>position</b> | <b>Remarks</b> |
|-------------------|-------------------------------|--|---------------------------|--|---|----------------|
|                   |                               |  |                           |  |   |                |
|                   |                               |  |                           |  |   |                |
|                   |                               |  |                           |  |   |                |
|                   |                               |  |                           |  |   |                |
|                   |                               |  |                           |  |   |                |
|                   |                               |  |                           |  |   |                |
|                   |                               |  |                           |  |   |                |
|                   |                               |  |                           |  |   |                |
|                   |                               |  |                           |  |   |                |
|                   |                               |  |                           |  |   |                |
|                   |                               |  |                           |  |   |                |

Seal of the firm

Signature of the bidder with date



**ANNEXURE VIII**

**SAMPLE FORMAT FOR EVIDENCE OF ACCESS TO OR AVAILABILITY OF CREDIT FACILITIES  
– CLAUSE 7.1.9**

**BANK CERTIFICATE**

This is to certify that M/s..... is a reputed company with a good financial standing.

If the contract for the work, namely..... is awarded to the above firm, we shall be able to provide overdraft/ credit facilities to the extent of Rs..... to meet their working capital requirements for executing the above contract.

Name of Bank :

Senior Bank Manager:

Address of the Bank:

**ANNEXURE IX****DETAILS OF LITIGATION, IF ANY**

| <b>Sl. No</b> | <b>Name of the Govt. Dept. / Private Organization (Other party)</b> | <b>Cause of the litigation</b> | <b>Amount involved (Rs. In lakhs)</b> | <b>Award for (or) against bidder</b> | <b>Remarks / present stage</b> |
|---------------|---|--------------------------------|---------------------------------------|--------------------------------------|--------------------------------|
|               |   |                                |                                       |                                      |                                |
|               |   |                                |                                       |                                      |                                |
|               |   |                                |                                       |                                      |                                |
|               |   |                                |                                       |                                      |                                |
|               |   |                                |                                       |                                      |                                |
|               |   |                                |                                       |                                      |                                |
|               |   |                                |                                       |                                      |                                |
|               |   |                                |                                       |                                      |                                |
|               |   |                                |                                       |                                      |                                |

Note: Should be attested by the Notary Public.

Seal of the firm

Signature of the bidder with date

**ANNEXURE X**

**DECLARATION BY THE BIDDER:**

It is to certify that our firm .....  
.....has **not** been black listed / banned / debarred by any Central /  
State, Union Territory Government Department or undertaking / Organization.

Seal

.....  
.....

(Signature of the Bidder)

**ANNEXURE XI****DETAILS OF COMPONENTS PROPOSED TO BE SUBLET AND  
SUB CONTRACTORS INVOLVED**

| <b>Sl.<br/>No</b> | <b>Name of<br/>component<br/>proposed to<br/>be sublet</b> | <b>Name of the<br/>sub<br/>contractor</b> | <b>Details of<br/>experience in<br/>similar work</b> | <b>Annual turnover<br/>for the last<br/>5 years (Rs. In<br/>lakhs)</b> |
|-------------------|--|---|--|--|
|                   |  |   |  |  |
|                   |  |   |  |  |
|                   |  |   |  |  |
|                   |  |   |  |  |
|                   |  |   |  |  |
|                   |  |   |  |  |
|                   |  |   |  |  |
|                   |  |   |  |  |

Seal of the firm

Signature of the bidder with date

**ANNEXURE XII****TECHNICAL STAFF TO BE EMPLOYED**

I/We shall/Will employ the following technical staff as per the prescribed rules

| <b>Sl. No.</b> | <b>Name of the technical staff to be employed</b> | <b>Designation</b> | <b>Qualification</b> |
|----------------|---|--------------------|----------------------|
|                |   |                    |                      |
|                |   |                    |                      |
|                |   |                    |                      |
|                |   |                    |                      |
|                |   |                    |                      |
|                |   |                    |                      |
|                |   |                    |                      |
|                |   |                    |                      |
|                |   |                    |                      |
|                |   |                    |                      |
|                |   |                    |                      |
|                |   |                    |                      |
|                |   |                    |                      |
|                |   |                    |                      |
|                |   |                    |                      |
|                |   |                    |                      |
|                |   |                    |                      |
|                |   |                    |                      |

Seal of the firm

Signature of the bidder with date

## **VII- GENERAL CONDITIONS OF CONTRACT**

### **1. DEFINITIONS**

In the Contract (as hereinafter defined) the following words and expressions shall have its meanings hereby assigned to them, except where the context otherwise requires.

“Board” means Orissa Water Supply and sewerage Board, a statutory body constituted under OWSSB Act 1991 having its office at Satyanagar, Bhubaneswar 751 007 and any officer authorised to act on its behalf

“Employer” means the Orissa Water Supply and sewerage Board and shall include the officers duly authorised to act on its behalf

“Contractor” means the person or persons, firm or company whose tender has been accepted by the Employer and includes the authorised representatives, successors, heirs, executors, administrators

“Subcontractor” means any person or persons, firm or company named in the Contract as a Subcontractor for a part of the Works or any person or persons, firm or company to whom a part of the Works has been subcontracted with the consent of the Engineer and includes the authorised representatives, successors, heirs, executors, administrators of such Subcontractors

“Engineer” means the Project Engineer or any other Engineer appointed from time to time by the Employer to act as Engineer for the purposes of the works brought under this contract

“Engineer in charges” means the Executive Engineer or any other Engineer authorised by him.

“Engineer’s representative” means any Resident Engineer or assistant of the Engineer or any clerk of works appointed from time to time by the Employer or/the Engineer to perform the duties set forth in respect of this Contract.

“Contract” means the Invitation for Bids and amendment made thereof, Letter of Acceptance, the formal Agreement executed between the Employer and the Contractor together with the documents referred to therein, General Conditions of the Contract, Special Conditions, Specifications, Minutes of the pre Bid conference, Design, Drawings, Schedule of Rates and Prices, Bill of quantities, Rate of Progress etc., All these documents taken together shall be deemed to form one contract and shall be complementary to one another

The quality parameters laid down in relevant BIS, CPHEEO, Bid Documents etc., are to be followed and it is stipulated to complete the entire works in all respects satisfactorily and commission within the stipulated period and maintain the scheme for the specified period.

“Contract Price” means the sum stated in the Letter of Acceptance as payable to the contractor for the execution, completion and maintenance of the works, subject to such additions thereto or deductions there from as may be provided under this Contract and the remedying of any defects therein in accordance with the provisions of the contract.

“Constructional Plant” means all appliances or things of whatsoever nature required in or about the execution, completion or maintenance of the works but does not include materials or other things included to form or forming part of the permanent works.

“Works” shall include both permanent works and temporary works. “Permanent works’ means the works of permanent nature to be executed, completed and maintained (including Plant) in accordance with the contract. ‘Temporary works’ means all temporary works of every kind required in or about the execution, completion or maintenance of the works and remedying of the defects therein

Specification” means the schedules, detailed designs, technical data, performance Characteristics and all such particulars referred to in the bid/contract and any modification thereof or addition thereto as may from time to time be furnished or approved by the Employer.

Drawings” means the drawings, calculations and technical information referred to in specification and any modification of such drawings approved in writing by the Engineer and such other drawings, calculations and technical information as may to time be furnished or approved in writing by the Engineer.

“Site” means the land and other places on, under, in or through which the Permanent works and/or Temporary Works are to be executed and any other lands and places provided by the Employer for working space or any other purpose as may be specifically designated in the Contract as forming part of the site.

Approved means approval in writing including subsequent written confirmation of previous verbal approval

“Test” means such test or tests as are prescribed in the specifications or considered necessary by the Engineer

‘ISS” means Indian Standard Specifications

“BIS” means Bureau of Indian Standards

“Day” means a Calendar day from midnight to midnight

“Week” means seven consecutive days.

“Month” means from the beginning date of a given date of a calendar month to the end the preceding date of the next calendar month

“Quarter” means a period of three months reckoning from the 1st date of January April, July and October and counted to the last date of March, June, September and December respectively.

Rupees means Rupees in Indian Currency

“Bill of Quantities” means the priced and completed bill of quantities forming part of the tender

“Tender” means the Contractor’s priced offer to the Employer for the execution, completion and maintenance of the Works and the remedying of any defects therein in accordance with the provisions of the Contract, as accepted by the Letter of acceptance

Letter of Acceptance” means the formal acceptance by the Employer of the Tender

“Contractor Agreement” means the contract agreement referred to in clause(..)

Appendix to Tender” means the appendix comprised in the form of Tender annexed in these conditions.

“Commencement Date” means the date of signing the agreement or the date of handing over the site to the successful firm/contractor, whichever is earlier and this shall be reckoned as the start date of the project.

“Time of Completion” means the time for completing the execution of and passing the Tests on Completion of the Works of any section or part thereof as stated in the Contract (or as extended under Clause...) calculated from the Commencement Date

“Trial run” means the successful Trial run of the completed and commissioned project as a whole or in parts as the case may be for the stipulated period

## **2. Interpretation**

In interpretation of these Conditions of Contract, headings shall not be deemed part thereof or be taken into consideration. Words importing persons or parties shall include firms and corporations and any organization having legal capacity. Words importing the singular only also include plural and vice versa where the context requires.

The Employer will provide instructions clarifying the queries about the contract

## **3. Authority of Engineer in Charge**

It shall be accepted that the authority of the Engineer in charge shall be an integral part of the contract in all matters regarding the quality of materials, workmanship, removal of improper work, interpretation of the contract drawings and specifications, mode and procedure of carrying out the works where the decision of the Engineer in charge shall be final and binding on the contractor. The Engineer in charge shall have absolute authority on all technical matters and payment considerations.

## **4. Sufficiency of Bid**

The Contractor shall be deemed to have satisfied himself as to the correctness and sufficiency of the bid and of the rates and prices stated in the Bill of Quantities, all of which shall, except insofar as it is otherwise provided in the contract, cover all his obligations under the Contract (including those in respect of the supply of goods, materials, Plant or services or of contingencies for which there is a Provisional Sum) and all matters and things



necessary for the proper execution and completion of the Works and the remedying of any defects therein.

### **5. Priority of Contract Documents**

The several, documents forming the Contract are to be taken as mutually explanatory of one another, but in case of ambiguities or discrepancies the same shall be explained and adjusted by the Engineer who shall thereupon issue to the Contractor instructions thereon and in such event, unless otherwise provided in the Contract. The priority of the documents forming the Contract shall be as follows:

- The Contract Agreement
- The Letter of Acceptance
- The Tender
- Conditions of the Contract
- Technical specifications
- Any other document forming part of the Contract

### **6. Secrecy of the contract document**

The Contractor shall treat all documents, correspondence, direction and orders concerning the contract as confidential and restricted in nature by the contractor and shall not divulge or allow access to these matters to any unauthorized person.

### **7. Instruction in Writing**

Instructions given by the Engineer or Engineer's Representative shall be in writing, provided that if for any reason, the Engineer or the Engineer's Representative considers it necessary to give any such instruction orally, the Contractor shall comply with such instruction. Confirmation in writing of such oral instruction given by the Engineer or Engineer's Representative, whether before or after the carrying out of the instructions given by the Engineer or Engineer's Representative, shall be deemed to be an instruction.

### **8. Commencement of Works**

The Contractor shall commence preliminary works after the receipt by him of the LOA to this effect from the Engineer in charge. Thereafter, the contractor shall proceed with the Works with due expedition and without delay and in accordance with the programme schedule set out in the Contract.

## 9. Reference Marks

The basic center lines, reference points and bench marks shall be fixed by the Engineer in charge of the works.

The contractor shall establish additional reference points and bench marks as may be necessary at his cost. The contractor shall remain responsible for the accuracy and sufficiency of the reference and bench marks. The contractor shall take proper precautionary steps to ensure that the reference lines and bench marks established for the works are not disturbed and shall make good any damages caused.

## 10. Supervision

The Contractor shall provide all necessary superintendence during the execution of the works and thereafter as may be necessary for the proper fulfillment of the obligations under this contract. The contractor shall arrange for the deployment of proper qualified personnel at the site of work constantly, such supervising staff, apart from those separately set out as the requirements of the contract, shall be skilled and experienced technical assistants, foremen and others competent enough to produce proper supervision.

The Contractor shall employ the technical staff as per the prescribed rules. The details of value, scale and minimum qualification prescribed for the employment of technical staff, the rate of penalty for the failure on the part of the contractor to employ the technical staff for the work etc are as follows

| Sl. No | Scale and minimum qualification prescribed for the employment of technical staff                    | No. of persons required | Rate of Penalty                |
|--------|---|-------------------------|--------------------------------|
|        | <b>Above Rs. 1.00 Crore to 50.00 Crore.</b>   |                         |                                |
| 1)     | <b>Project Manager BE (Civil)</b> or equivalent with 15 years experience.                           | 1                       | Rs.25000/- per month / Person. |
| 2)     | <b>Deputy Project Manager BE (Civil)</b> or equivalent with 10 years experience                     | 1                       | Rs.15000/- per month / Person. |
| 3)     | <b>Resident Engineer BE (Civil) / Mechanical / Electrical</b> or equivalent with 5 years experience | 2                       | Rs.10000/- per month / Person. |

If the contractor fails to employ the technical staff to the departmental requirements, the contractor is liable to pay the penalty as indicated above during the period of such non employment of technical staff.

In the event of any staff of the contractor being non co-operative, negligent, incompetent or misconduct, the Engineer in charge shall have the liberty to object to the placement of such staff at the site or other place of works and will promptly issue notice in writing to the

contractor for the removal of such staff members. It will be obligatory on the part of the contractor to remove/change such persons in the larger interests of the works.

### **11. Subletting of Contract**

Assignment of the contract is not permissible

Transfer of the contract is not permissible on any grounds

The contractor shall sublet any portion of the contract only with the written consent of the Engineer in charge. It should be clearly understood that any subletting shall in no way absolve the contractor of his responsibilities and obligations under this contract

### **12. Specifications and Checks**

Stated dimensions in the drawings are to be taken for consideration and no measurements based on scaling of the drawings shall be considered. In case of discrepancy between the description of items in the schedule of quantities and the specifications, the later shall prevail. In case of the description, any work having not fully described or doubts prevail, the contractor shall forthwith write to the Engineer in charge and clarify himself before executing that portion of the work. However, this cannot be a cause for any delay in the progress and the contractor should take advance action in this regard ensuring timely completion of the works. Before commencement of the work, it will be obligatory on the part of the contractor to furnish a detailed plan of action along with layouts showing the position of the construction plants and other facilities required and proposed to be provided for this contract.

The contractor shall execute the works true to alignment, grade and levels as set out in the drawings and as directed by the Engineer in charge from time to time. The Engineer in charge or his representative is at liberty to check the correctness of the works, the suitability of the materials used, design mix etc., The contractor will raise no objections for such checks and shall provide necessary labour and instruments to carry out such check to the Engineer in charge as well as his representative and co-operate in the checks. However, such checks will not absolve the contractor of his responsibility of maintaining the accuracy of the work.

### **13. Custody and Supply of Drawings and documents**

The drawings shall remain in the sole custody of the Engineer in charge, but two copies thereof shall be provided to the contractor free of charge. The contractor shall make at his own cost any further copies required by him. Unless it is strictly necessary for the purposes of the contract, the drawings specifications and other documents provided by the Employer or the Engineer in charge shall not, without the consent of the Engineer in charge, be used or communicated to a third party by the contractor. One copy of the Drawings, provided to or supplied to the Contractor as aforesaid, shall be kept by the Contractor at the site and the same shall be made available for inspection and use by the Engineer and by any other person authorized by the Engineer.

### **14. Bill of Quantities**

The Bill of quantities shall contain items for the construction, installation, testing, commissioning and Trial run of the Works to be carried out by the Contractor.

The Bill of Quantities will be used to calculate the Contract Price. The contractor shall be paid for the quantum of work done at the rate mentioned for each item in the Bill of quantities

### **15. Change in the Quantities**

If the final quantity of the work done differs from the quantity in the Bill of Quantities for the particular item/items, the rates as in the agreement for the relevant items shall be paid as per the actual quantity.

### **16. Additional items**

If additional items that are not contemplated in the contract are to be executed, the Engineer in charge will execute the works either through the main contractor/firm or through any other agency. Payment for such works shall be made based on the rates derived by the Engineer in charge as per rules in force.

### **17. Order Book**

An order book will be kept by the Officer in charge of the site (Junior Engineer/Assistant Engineer) of the particular component of the works. Orders entered in this book by the Engineer in charge or any higher authority shall be held to have been formally communicated to the contractor/firm. The Officer in charge of the site will sign each order as it is entered and will hand over the duplicate to the contractor/firm or his agent, who shall sign the original in acknowledgement of having received the order.

### **18. Independent Inspection**

The Engineer shall delegate inspection and testing of materials or Plant to an independent inspector/Agency. Any such delegation shall be considered as prerogative of the Engineer. In addition to third party inspection, wherever felt necessary, the engineer shall be empowered to test the PVC Pipes for its quality such as specific gravity, diameter, thickness etc. in the TWAD Board laboratory. The cost of the third party quality check pipes, valves and pump sets shall be borne by the employer.

### **19. Covering and Opening of Works.**

No work shall be covered or put out of view without the approval of the engineer in charge. The contractor shall give due notice to the Engineer in charge whenever such works are ready for examination and the Engineer in charge within a reasonable period, arrange for the inspection and measuring of the work as may be necessary. No portions of the work shall be covered up without the consent of the Engineer in charge. The cost of opening any portion of the works that was covered without the consent of the Engineer in charge and the cost of covering thereafter shall be borne by the contractor. The contractor shall open the covered portion of the works for inspection by the Engineer in charge on a request and the inspection or examination shall be carried out promptly by the Engineer in charge. In the case of defects notified by the Engineer in charge, the contractor shall rectify the same as may be instructed by the Engineer in charge. All costs of opening, covering and rectification shall be on to the account of the contractor. Should the contractor refuse to open such portions of works the Engineer in charge shall open such portions with other persons and inspect the part of the works as he may feel necessary. On inspection, the works being not in accordance with the requirements of the contract documents, the Engineer in charge shall

carry out necessary rectification and the entire cost of opening, rectification and closing shall be on to the contractor's account.

## **20. Temporary Diversion of Roads and Commencement of Work.**

During execution of the works, the contractor/firm shall make at his cost all necessary provision for the temporary diversion of roads, car tracks, foot paths, drains, water courses, channels etc., Should the contractor/firm fail to do these arrangements, the same shall be done by the Engineer in charge and the cost thereof shall be recovered from the contractor/firm.

## **21 Notice to Telephone, Railway and Electric Supply Undertaking.**

The Contractor/firm shall give all notices required by any law or custom or as directed by the Engineer in charge and irrespective of whether notice be so required so directed or not, shall in all cases give due and sufficient notices to all persons and authorities having charge of the telegraph, water and other pipes, sewers, culverts drains, water courses, railway, telephone, highways, roads, streets, foot and carriage highways, payment and other works, prior to commencements and at the completion of any work under this contract in order to enable the proper bodies or persons in respect of the matters aforesaid to attend and see the works within their jurisdiction and all matters and things incidental and pertaining thereto are secured, re-laid or reinstated in a proper and satisfactory manner. The notices by the contractor/firm shall also serve the purpose of enabling such bodies and persons to attend and secure, shore up, alter the position or remove, relay and reinstate the works and things belonging to them notwithstanding the notices given as aforesaid the Contractor/firm shall be chargeable and responsible for the proper protection and restoration of all matters and things herein referred to.

## **22 Watching and Lighting**

The Contractor/firm shall at his expense shall provide at the site of works sufficient fencing, barricading, watching and lighting during day and night. The contractor/firm shall in every respect conform to the police regulations in these matters and shall free and relieve the Board on all such matters. Should the contractor/firm fail/neglect to do these arrangements, the same shall be carried out by the Engineer in charge and the costs thereof shall be recovered from the contractor/firm.

## **23 Measurement of Work**

The work will be measured by the site engineer (Junior Engineer/Assistant Engineer) and recorded in the measurement book. The contractor/firm will be at liberty to accompany the site engineer in order that they may agree on the measurements but should they neglect to do so, the measurements as recorded by the site engineer shall be taken as final and conclusive. The measurements of works will be recorded as prescribed in the TNBP and as amended from time to time.

## **24 Tools and Plants**

All tools, plants and equipment required for this contract will be arranged by the Contractor at his own expense. The Contractor shall erect necessary construction plant as may be necessary and shall use such methods and appliances for the proper performance of all the

operations connected with the work brought under the contract ensuring satisfactory quality of work and maintenance of the programme schedule. The non-availability of any tool, plant or equipment shall not be relied upon as a reason for non-functioning or slow progress.

## **25 Information and Data**

The information and data made available to the contractor in respect of the works and site conditions are only general and the contractor is advised to get himself fully acquainted with the nature of the location of the works and the surroundings, quarries, local conditions and such other aspects that are relevant to the works.

## **26 Coexistence with other Contractors.**

Where two or more contractors are engaged on work in the same vicinity, they shall work together harmoniously with the spirit of cooperation and accommodation. The contractor shall not disrupt or disturb the works or labour arrangements of the neighboring contractors. In case of disputes and difficulties arising between the contractors in the execution of the respective works, the Engineer in charge shall interfere and give directions for the smooth functioning of the entire works and it shall be the bounden duty of the contractors to abide by these instructions.

## **27 General Responsibilities and Obligations of the Contractor**

The contractor shall, subject to the provisions of the contract, execute and maintain the works with proper care and diligence and provide all labour including the supervision thereof, materials, constructional plant and all other things, whether of a temporary or permanent nature required for such execution and maintenance.

The contractor shall take full responsibility for the adequacy, stability and safety of all site operation and methods of construction.

The contractor shall promptly inform the Employer and the Engineer in charge if any error omission, fault and other defects in the specification or design of the works which are identified at the time of reviewing the contract documents or during the execution for proper rectification thereof.

All notices, certificates connected with the work served by the employer relating to the contract shall be sent by post or by hand to the contractor' principal place of business as mentioned in the document or at other places as may nominated by the contractor in writing for this purpose. Any change in the address of the contractor should be promptly intimated to the Employer in writing then and there.

The contractor shall visit the spots of work and ascertain the site conditions. The contractor shall satisfy himself of the conditions prevailing in the spots where the work is actually to be executed and its environs and the precise offered by him shall be treated as those which were worked out taking fully into consideration the prevailing site conditions, hydrological conditions, extent and nature of work to be executed, the material availability, etc., Any claim on this ground at a later date shall be summarily rejected.

However, during the execution of the works, if the contractor has to encounter artificial obstructions, which in his opinion could not have been reasonably foreseen, then the

contractor shall write forthwith to the Engineer in charge of such obstruction and remedial measures needed. The Engineer in charge, if opined that the conditions cannot be possibly foreseen by an experienced contractor, he shall extend possible assistance to the contractor to overcome such obstructions. The opinion of the Engineer in charge shall be final and binding and the contractor is not entitled to advance these as reasons for any delay that may be caused to the completion of the project.

The contractor shall execute and maintain all works in accordance with the specification and to the satisfaction of the Employer. The contractor shall strictly adhere to the instructions and directions of the engineer in charge, whether included in the contract agreement or not but concerning the safe and proper execution of the works.

## **28 Labour**

The contractor shall not employ any person who has not completed fifteen years of age in connection with the works under this contract.

The contractor shall furnish the information on various categories of labour employed by him to the Engineer in charge in the form prescribed for this purpose

The contractor shall in respect of labour employed by him comply with or cause to be complied with the provisions of various labour laws, rules and regulations as applicable to them in regard to all matters provided therein and shall indemnify the Employer in respect of all claims that may be made against the Employer for non-compliance thereof by the contractor.

Now withstanding anything contained herein, the Employer reserves the right to take such action as may be deemed fit and proper for the compliance of various labour laws and recover the costs thereof from the contractor.

## **29 Restriction of Working Hours**

Subject to any provisions contained in the Contract, none of the works shall, save as hereinafter provided, be carried on during the night or on locally recognized days of rest without the consent of the Engineer, except when work is unavoidable or absolutely necessary for the saving of life or property or for the safety of the Works, in which case the Contractor shall immediately advise the Engineer, Provided that the provisions of this clause shall not be applicable in the case of any work which is customary to carry out by multiple shifts

### **30. Right of Way and Facilities**

The Contractor shall bear all costs and charges for special or temporary rights of way required by him in connection with access to site. The Contractor shall also provide at his own cost any additional facilities outside the Site required by him for the purposes of the Works

### **31. Removal of Improper Work, Material and Plant**

The contractor shall make his own arrangements for the procurement, supply and use of the construction materials and shall ensure that the materials either procured within the country or abroad conform to the relevant specifications set out in the bid documents. In case of alternatives being used, they should be of equal or higher quality than those specified subject to the review and written approval of the Engineer in charge. Differences between the standards specified and the proposed alternatives must be described in writing to the Engineer in charge at least 30 days in advance from the date on which the approval of the Engineer in charge is needed. The disapproval of the proposal by the Engineer in charge shall result in the contractor confining to the standards set forth in the contract documents. The contractor shall arrange for the inspection of the material at the manufacturing place or other places by the department personnel

All materials and workmanship shall be in accordance with the specifications set out in the contract document and as directed by the Engineer in charge and shall be subjected to tests by the Engineer in charge or his representative at the place of manufacture or at the site of work or places wherever felt necessary. The contractor shall provide all the assistance necessary including instruments, machines and materials that are normally required for carrying out the testing/measuring the quality/quantity of the materials and workmanship. Any material rejected after testing by the Engineer in charge or his representative will not be used on the works. The contractor shall without claiming any extra cost, shall arrange for the testing of materials and supervision of the works. The Engineer in charge or his authorized representative will have access at all times to the places of manufacture, storage to ascertain as to whether the manufacturing process wherever mentioned is in accordance with the drawings and specifications

The Engineer in charge shall have the right to order the removal of such materials which in his opinion are substandard stipulating a time limit for the removal of the same and replacement with quality material

Notwithstanding the previous tests of the materials by the Engineer in charge or his representative, if any portion of the work, in the opinion of the Engineer in charge is not in order, the contractor shall redo such work to the satisfaction of the Employer at no extra cost. In case of default on the part of the contractor in carrying out such orders, then the Employer shall have the right to carry out such works through some other persons and the expenses thereon or incidental thereto shall be recoverable from the contractor.

### **32. Default of Contractor in Compliance**

In case of default on the part of the Contractor in carrying out such instruction within the time specified therein, if none, within a reasonable time, the Employer shall be entitled to employ and pay other persons to carry out the same and all costs consequent thereon or incidental



thereto shall after due consultation with the Employer and the Contractor, be determined by the Engineer and shall be recoverable from the Contractor by the Employer, and shall be deducted by the Employer from any monies due or to become due to the Contractor and the Engineer shall notify the Contractor accordingly, with a copy to the Employer

### **33. Default by Contractor**

If the contractor shall become bankrupt or have a receiving order made against him or shall present his petition in bankruptcy or shall make an arrangement with or assignment in favour of his creditors or shall agree to carry out the contract under a committee of inspection of his creditors, or being a corporation shall go into liquidation (other than a voluntary liquidation for the purpose of amalgamation or reconstruction), or if the contractor shall assign the contract, without the consent in writing of the employer first obtained, or shall have an execution levied on his goods, or if the engineer in charge shall certify in writing to the employer that in his opinion, the contractor.

- a) Has abandoned the contractor or
- b) Without reasonable excuse has failed to commence the works or has suspended the progress of work for twenty eight days after receiving a written notice from the Engineer in charge to proceed or
- c) Has failed to remove materials from the site or to pull down and replace work for twenty eight days after receiving the written notice from the engineer in charge stating that the said materials or work stands condemned and rejected under these conditions, or
- d) Despite previous warnings in writing by the Engineer in charge, not executing the works and achieving the progress as stipulated in the programmed schedule drawn for the contractor is persistently or flagrantly neglecting to carryout the obligations under this contractor
- e) Has, to the detriment of good workmanship, or in defiance of the instructions of the Engineer in charge or in contract sublet any part of the contract, then the Employer, may at his option, after giving two weeks' notice in writing to the contractor, enter upon the site and the works and expel the contractor therefrom without thereby voiding.
- f) The contract, or releasing the contractor from any of his obligation or liabilities under this contract, and may himself complete the works or may employ any other contractor to complete the work. The employer or such other contractor may use the construction plant, temporary works and materials which have been deemed to be reserved exclusively for the execution of the works under the provisions of the contract as may be thought fit and proper for the completion of the work. The employer may, at any time, sell any of the said constructional plant, temporary works and materials which have been deemed to be reserved exclusively for the execution of the works under the provisions of the contract as may be thought fit and proper for the completion of the work. The employer may, at any time, sell any of the said constructional plant, temporary works and unused materials and apply the proceeds of sale in or towards the satisfaction of any sums due or which may become due to him from the contractor under this contract.

- g) has carried out the work in a defective manner.
- h) has not made payment of labour dues.
- i) has become eligible for maximum compensation under the "Liquidated damages clause" leading to Termination of the contract.

The *Engineer in charge* shall as soon as may be practicable after any such entry or expulsion by the employer, fix and determine expert or by after reference to the parties, or after such investigation or enquiries as maybe thought fit to make or institute, and shall clarify what amount, if any had at the time of such entry and expulsion been reasonably occurred to the contractor in respect of work then actually done by him under this contract and the value of any of the said unused or partially used materials, any constructional plant and any temporary woks.

If the employer shall enter and expel the contractor under this clause, the employer shall not be liable to pay to the contractor any money on account of the contract until the expiration of the period of maintenance and thereafter until the costs of execution and maintenance, damages for delay in completion, if any and all other expenses incurred by the Employer have been ascertained and the amount thereof certified by the engineer. The contractor shall then be entitled to receive only such sum or sums, if any as the engineer in charge may certify would have payable to him upon due completion by him after deducting the said amount. If such amount shall exceed the sum which would have been payable to the contractor on due completion by him, then the contractor shall, upon demand, pay to the employer the amount of such excess and it shall be deemed a debt due by the contractor to the Employer and shall be recoverable accordingly.

If, by reason of any accident, or failure, or other event occurring to or in connection with the work, or any part thereof, either during the execution of the works, or during the period of maintenance, any remedial or other work or repair shall in the opinion of the Engineer in charge or his authorized representative, be urgently necessary for the safety of the works and the contractor is unable or unwilling at once to do such work or repair as the Engineer in charge or his representative may consider necessary, such works shall be carried out by the Engineer in charge. If the work or repair so done, which in the opinion of the Engineer in charge, liable to have been done by the contractor at his expense under this contract, all expenses incurred by the Employer in carrying out such works shall be recoverable from the contractor or shall be deducted by the Employer from the money due to the contractor provided always that the Engineer in charge or his representative, as the case may be, shall as soon after the occurrence of any such emergency as may be reasonably practicable, notify the contractor thereof in writing.

### **34. Power to vary work**

The description of the works required to be executed by the contractor/firm are set out in the specifications, schedules and drawings, but the Engineer in charge reserves the power to vary, extend or diminish the quantities of work, to alter the line, level or position of any work, to increase, change or decrease the size, quality, description, character or kind of any work, to order the contractor/firm to execute the works or any part thereof, by day or night work, or to add or take from the work included in the contract as he may deem fit and proper without violating the contract and the contractor/firm shall not have any claim upon the Employer for any such variation, extension, diminution, alteration, increase, change or

decrease other than for the work actually done, calculated according to the prices tendered and accepted in this contract.

### **35. Extra for Varied Works**

Any unforeseen additional work that may become necessary and is accordingly carried out under this contract based on proper written orders shall be measured and valued by the Engineer in charge at the rates contained in the contractor's/firm's original bill of quantities. If these rates do not apply to the additional works ordered to be carried out, then prior to execution of the additional work, a rate for such work shall ordinarily be agreed upon and entered in a supplemental schedule and signed by both the Engineer in charge and the contractor/firm.

### **36. Omissions**

In the event of anything reasonably necessary or proper to the due and complete performance of the work (Engineer in charge will be the sole judge on these things) being omitted to be shown or described in the drawings, specifications and schedules, the contractor/firm shall notwithstanding execute and provide at the rates noted in the bill of quantities all such omitted works and things as if they have been severally shown and described and the execution should be according to the directions of the Engineer in charge and to his satisfaction.

### **37. Notices Regarding Shoring etc.,**

Wherever shoring or other works for the protection or security of the buildings/structures are necessary, the contractor/firm shall within a reasonable period before the execution of such works, shall serve notices upon the occupiers of the buildings / structures to be shored up or otherwise secured and upon all other parties entitled to notice, apprising them respectively that such works are necessary, that the contractor/ firm about to execute the same and will, at a time to be specified in such notice, enter upon the premises for the purpose of executing such works.

### **38. Cost of Repairs**

Loss or damage to the Works or materials to be incorporated in the works between the Start Date and the end of the Defects correction periods shall be remedied by the Contractor at the Contractor's cost if the loss or damage arises from the Contractor's acts or omissions.

***Contractor shall attend to the defect in the work noticed during defects correction period within 3 days from the date of issue of notice to attend to the defects, failing which the defect will be remedied by engaging other Contractors at any cost and that cost will be recovered from the Contractor's money available with the Employer and balance alone will be paid when it is due.***

### **39. Suspension of Work**

The Contractor shall, on the instructions of the engineer, suspend the progress of the Works or any part thereof for such time and in such manner as the Engineer may consider necessary and shall, during such suspension, properly protect and secure the Works or such part thereof so far as is necessary in the opinion of the Engineer in charge.

### **40. Suspension of Progress**

The contractor/firm shall, without recompense, claim or demand, delay or suspend the progress of works as a whole or any part thereof, if and when or so often as directed by the Engineer in charge and for such time or times, as may be in the judgement of the Engineer in charge be necessary for the purposes or advantages of the undertaking. Upon all such occasions, whether directed or not, the contractor/firm at his/their expense, properly cover down and secure so much of the work as may be liable to sustain damage from whether or any other cause and shall at all times and forthwith when required properly make good all the damage or injury which such works or any part thereof may give sustained and these should be done to the entire satisfaction of the Engineer in charge.

### **41. Termination**

The Employer may terminate the Contract for any reason that is regarded as breach of the Contract.

If the contract is terminated, the contractor shall stop work immediately, make the site safe and secure and leave the site as soon as reasonably possible on termination of the contract, the Engineer shall issue a certificate for the value of work done less payments received up to the date of the issue of certificates, less other recoveries due in terms of the contract, less taxes due to be deducted at source as per applicable law and less the percentage to apply to the work not completed. If the total amount due to the Employer exceeds any payment due to the Contractor the difference shall be treated as debt payable to the Employer and can be recovered from any amount due or may become due to the contractor.

In the case of termination, works that are pending for the proper completion of the project, shall be carried out by the Employer either by themselves or through any other agency. Any additional expenditure over the value finalised in the contract for any component or for the whole project, incurred by the Employer by the Employer due to such termination, shall become recoverable from the contractor/firm whose contract stands terminated, from the money due or may become due to him/them. All materials on the Site, Plant, Equipment, Temporary Works and Works are deemed to be the property of the Employer, if the Contract is terminated because of Contractor's default

### **42. Plant etc. not to be removed**

The plant, tools and materials provided by the contractor/firm shall, from the time they are brought to the site of the works, during the construction and until the satisfactory completion of the contract, shall become and continue to be the property intended for the proper fulfillment of the contract and the contractor/firm shall not remove the same or part thereof without the consent of the Engineer in charge in writing.

**43. Contractor not to occupy Land etc.,**

In no case shall the contractor/firm continue to use or occupy or allow to be used or occupied any land or property either for the deposit of materials or plant or for any purpose whatever, after written notice from the Engineer in charge served on the contractor/ firm to the effect requiring the contractor/firm to remove or cause to be removed all such materials from any such land or property as aforesaid and to give vacant possession of such land or property to the Engineer in charge. All such notices shall be served through post office or other modes of delivery to the contractor/firm at his/their usual or last known place of business, It is enough for the Engineer in charge to send the notice through any mode of delivery as he may prefer and implement this clause irrespective of the receipt of the notice by the contractor/firm. Should any materials or plant remain upon any such property or land or should any such land or property continue to be occupied or be used after such notice for any purpose whatsoever as aforesaid, then and in every such case and as often as the same shall happen, the contractor/firm shall forfeit and on demand pay to the Employer the charges fixed by the Engineer in charge as and for liquidated and ascertained damages for each and every day during which the said lands or property are so used and occupied as aforesaid from the time of such notice shall have been served.

**44. Power Supply**

The power supply connection from the NESCO has to be obtained by the contractor himself and the charges thereon shall be borne by the contractor. However, necessary vouchers in original for the payment made to the NESCO shall be produced to the Employer by the contractor which will be reimbursed by the Employer.

**45. Completion and Delivery of the Works**

The completion and delivery of the works shall be deemed to be full, complete and sufficient only when the Engineer in charge accepts the same and issues a certificate in writing viz. " Certificate of Completion" under the hand of the Engineer in charge to the effect that all the works contracted for and directed to be executed have been completed and are in a sound, water tight, workmanlike and complete and usable condition and the contractor has in the opinion of the Engineer in charge reasonably fulfilled and completed his contract and undertaking except so far as it relates to the maintenance of the works as hereinafter provided. Provided always and notwithstanding anything contained in the contract, it shall be lawful for the Employer to undertaker and execute either departmentally or through other parties at any period during the continuance of this contract, any kind of work, matter or thing whatsoever, which they mat consider necessary or proper to be performed and executed for the purpose of any in connection with any or all of the works under this contract and that without in any way relieving the contractor/firm from any of his/their liabilities and responsibilities under this contract or in any way violating or voiding this contract.

**46. Final Certificate**

When the works covered under this contract are completed in all respects, the contractor / firm shall submit a request to the Engineer in charge to make a final measurement of the works and take over the whole of the works on behalf of the Employer

and issue a final certificate to enable him/them to submit a final bill for payment. The Engineer in charge shall thereupon, unless he records reasons in writing to the contrary, make a final measurement of the works and take them over on behalf of the Employer and sign a certificate purporting to be a last certificate. Nothing in this clause or in the agreement shall prohibit the Employer taking over and using any portion of the works which may be completed prior to the completion of the whole works of this contract.

#### **47. Completion Certificate**

The Contractor shall request the Engineer to issue a certificate of Completion of the Works and the Engineer shall issue certificate of completion after satisfactory completion of the works in all respects

#### **48. Taking Over**

The Employer shall take over the Site with the works within thirty days after satisfactory completion of the trial run of the entire project for the stipulated period as contemplated in this contract.

#### **49. Performance Guarantee**

The period of guarantee for the entire works shall be 24 months from the date of completion and commissioning of the project and trial run period to the satisfaction of the Engineer in charge of the work. If defects are noticed during the guarantee period, the firm/contractor shall rectify/replace wherever necessary at its/his own cost within 30 days of such intimation. If the contractor/firm fails to carry out rectification within the stipulated time, the rectification works shall be carried out by the Employer at the risk and cost of the contractor/firm and contractor/firm will become ineligible for the payment of the retention amount for the said purpose.

#### **50. Trial run of the project**

The contractor / firm shall successfully maintain the project for the stipulated Trial run period from the successful commissioning of the works in this project.

#### **51. Operating and Maintenance Manual**

“As built” drawings and operating and maintenance manuals shall be supplied by the contractor/firm at the time of handing over the completed works at his/their cost as instructed by the Engineer in charge.

#### **52. Work on Private Property**

The contractor/firm shall not commence any work in or upon, under, across of through any land, house building, shed, yard, area, roadway, ground, garden or any other place being private property until authorised in writing by the Engineer in charge to do so.

### **53. Protection**

It will be the responsibility of the contractor to take adequate precautions and protect the adjoining sites against structural, decorative and other damages. The contractor shall be responsible for the safety of the public properties wherever the works are executed. Whenever damages are caused to the adjoining structures, roads, bridges etc due to the execution of this contract, it will be the responsibility of the contractor to restore them to their original level at his cost.

### **54. Accident or Injury to Workmen**

The Employer shall not be liable for or in respect of any damages or compensation payable to any workman or other person in the employment of the Contractor or any Subcontractor. The Contractor shall indemnify and keep indemnified the Employer against all such damages and compensation and against all claims, proceedings, damages, costs, charges and expenses whatsoever in respect thereof or in relation thereto

### **55. Risk Insurance**

The firm/Contractor shall provide risk insurance at their/his cost against loss or damages to the construction to cover from the start date to the end of the Defects Liability Period, for the following events

- Loss of or damage to the Works, Plant and Materials
- Loss of or damage to Equipment
- Loss of or damage of property (except the Works, Plant, Materials and Equipment) in connection with the Contract and
- Personal injury or death

Policies and certificates for insurance shall be delivered by the Contractor to the Engineer for the Engineer's approval before the Start Date. All such insurance shall provide for compensation to be payable in the types and proportions of currencies required to rectify the loss or damage incurred. The contractor will not be eligible for any payment on this account.

If the Contractor does not provide any of the policies and certificates required, the Employer shall effect the insurance which the Contractor should have provided and recover the premiums the Employer has paid from payments otherwise due to the Contractor or, if no payment is due, the payment of the premiums shall be a debt due

Alterations to the terms of insurance shall not be made without the approval of the Engineer.

### **56. Care and Risk**

From the date of commencement to the date of completion of the work and during the period of maintenance, the contractor shall take full responsibility and care thereof for the safety of the installation connected with the works. Any damage or loss are to be made good at the risk and cost of the contractor and shall ensure conformity in every respect with the requirements of the contract. The contractor shall be liable for any damage to the works occasioned by him in the course of any operation carried out by him for the purpose of

completing any outstanding work and the damage so occurred shall be rectified at the cost of the contractor.

## **57. Safety Provisions**

The Contractor shall be responsible for the safety of all activities on the Site.

1) Suitable scaffolds shall be provided for workers for all that cannot safely be done from the ground or from solid construction, except such short period work, as can be done safely from ladders. When a ladder is used, an extra mazdoor shall be engaged for holding the ladder and if the ladder is used for carrying materials as well, suitable footholds and handholds shall be provided on the ladder and the ladder shall be given an inclination no steeper than 1\4 to 1 (1\4 horizontal to 1 vertical). IS code for scaffolding and ladders I.S 3696 Part -I and Part II and its latest revisions is to be followed.

2) Scaffolding or staging more than 3.25 meters above the ground or floor swung or suspended from an overhead support or erection with stationary support, shall have guard rail properly attached bolted, braced and otherwise secured at least 1 meter high above the floor or platform of such scaffolding or staging and extending along the entire length of the outside and ends thereof with only such openings as may be necessary for the delivery of materials. Such scaffolding or staging shall be so fastened as to prevent it from swaying from the building or the structure.

3) Working platform, gangways and stairways shall be so constructed that they do not sag unduly or unequally, and if height of a platform or gangways or stairway is more than 3.25 metres above ground level, it shall be closely boarded, having adequate width and be suitably fenced, as described in 2 above. Every opening in floor of a building or in a working platform shall be provided with suitable means to prevent fall of persons or materials by providing suitable fencing or railing with a minimum height of 1 meter. Safe means of access shall be provided to all working platforms and other working places. Every ladder shall be securely fixed. No portable single ladder shall be over 7 metres in length. Width between side rails in a rung ladder shall in no case be less than 30 cm, for ladders, this width shall be increased by at least 6mm for each additional 30cm length. Uniform steps spacing shall not exceed 30cm.

4) Adequate precautions shall be taken to prevent danger from electrical equipment. No material on any of the sites shall be so stocked or placed as to cause danger or inconvenience to any person or to the public. The Contractor shall provide all necessary fencing and lights to protect public from accidents and shall be bound to bear expenses of defence of every suit, action or proceedings at law that may be brought by any person for injury sustaining, owing to neglect of the above precautions and to any such suit, action or proceedings to any such person or which may with the consent of the Contractor be paid to compromise any claim by any such person.

5) All necessary personal safety equipment as considered adequate by the Engineer shall be available for use of persons employed on the site and maintained in a condition suitable for immediate use and the Contractor shall take adequate steps to ensure proper use of equipment by those concerned.



a) Workers employed on mixing asphalt materials, cement and lime mortars /concrete shall be provided with protective footwear, hand gloves and goggles.

b) Those engaged in handling any materials, which is injurious to eyes, shall be provided with protective goggles.

c) Stone breakers shall be provided with protective goggles and protective clothing.

d) When workers are employed in sewers and manholes, which are in use, the Contractor shall ensure that manhole covers are opened and manholes are ventilated at least for an hour before workers are allowed to get into them. Manholes so opened shall be cordoned-off with suitable railing and warning signals or boards provided to prevent accident to public.

e) The Contractor shall not employ men below the age of 15 and women on the work of painting with products containing lead in any form. Whenever men above the age of 18 are employed on the work of lead painting the following precautions shall be taken:

i) No paint containing lead or lead products shall be used except in the form of paste of ready-made paint.

ii) Suitable face masks shall be supplied for use by workers when paint is applied in the form of spray or a surface having lead paint dry rubbed and scraped.

iii) Overalls shall be supplied by the Contractor to workmen and adequate facilities shall be provided to enable working painters to wash during and on cessation of works.

6)When the work is done near any place where there is risk of drowning, all necessary equipment shall be provided and kept ready for use and all necessary steps shall be taken for prompt rescue of any person in danger and adequate provisions shall be made for prompt first aid treatment of all injuries likely to be sustained during the course of the work.

7)Use of hoisting machines and tacks including their attachments, anchorage and supports shall conform to the following:

a) i) These shall be of good mechanical construction, sound material and adequate strength and free from patent defects and shall be kept in good working order.

ii) Every rope used in hoisting or lowering materials or as a means of suspension shall be of durable quality and adequate strength, and free from patent defects

b) Every crane driver or hoisting appliance operator shall be properly qualified and no person under the age of 21 years shall be in-charge of an hoisting machine, including any scaffold winch or giving signals to operator.

c) In case of every hoisting machine and of every chain ring hook, shackle, swivel and pulley block used in hoisting machine or lowering or as means of suspension, safe working load shall be ascertained by adequate means. Every hoisting machine and all gear referred to above shall be plainly marked with safe working load. In case of hoisting machine having a

variable safe working load and the conditions under which it is applicable shall be clearly indicated. No part of any machine or of any gear referred to above in this paragraph shall be loaded beyond safe working load except for the purpose of testing.

d) In case of departmental machine, safe working load shall be notified by the Engineer. As regards Contractor's machine, the Contractor shall notify safe working load of each machine to the Engineer whenever he brings to the site of work and he shall get it verified by the Engineer.

8) Motors, gearing, transmission, electrical wiring and other dangerous parts or hoisting appliance shall be provided with such means so as to reduce to minimum risk and accidental descending of load; adequate precautions shall be taken to reduce to the minimum risk of any part of a suspended load becoming accidentally displaced. When workers are employed on electrical installations, which are already energized, insulating mats, wearing apparel such as gloves, sleeves and boots, as may be necessary shall be provided. Workers shall not wear any rings, watches and carry keys or other materials, which are good conductors of electricity.

9) All scaffolds, ladders and other safety devices mentioned or described herein shall be maintained in a safe condition and no scaffold ladder or equipment shall be altered or removed, while it is in use. Adequate washing facilities shall be provided at or near place of work.

10) The safety provision shall be brought to the notice of all concerned by displaying on a notice board at a prominent place at the work spot, persons responsible for ensuring compliance with the safety provision shall be named therein by the Contractor.

11) To ensure effective enforcement of the rules and regulations relating to safety precautions, arrangements made by the Contractor shall be open to inspection by the Engineer or his representative and the inspecting Officer.

12) The Contractor shall obtain prior permission of the competent authority such as Chief of Fire services for the site, manner and method of storing explosives near the site of work. All handling of explosives including storage, transport shall be carried out under the rules approved by the "Explosive Department of the Government".

13) The Contractor shall at his own cost provide and maintain at the sites of works, standard first aid box as directed and approved by the Engineer, for the use of his own as well as the Employer's staff on site.

14) Notwithstanding the above provision 1 to 15 Contractor is not exempted from the operation of any other Act or rules in force relating to safety provisions.

## **58. Provision of Health and Sanitary Arrangements**

The contractor/firm, shall provide at his/their own expenses, first aid appliances and medicines including an adequate supply of sterilized dressing and sterilized cotton wool kept in good order under the charge of a responsible person who shall be readily available during working hours.

Water of good quality fit for drinking purposes shall be provided for the work people on a scale of not less than 15 litres per head per day. Each water supply storage shall be at a distance of not less than 15 metres from any latrine, drain or other source of pollution. Where water has to be drawn from an existing well which is within such proximity of latrine, drain or other sources of pollution, the well shall be properly chlorinated before water is drawn from it for drinking.

Adequate washing and bathing places shall be provided separately for men and women and such places shall be kept in clean and drained condition. Latrines and urinals shall be provided within the precincts of work place and the accommodation separately for each of them shall be at the rate of 2 seats upto 50 persons, 3 seats above 50 persons but not exceeding 100 persons, and 3 seats for every additional 100 persons. The contractor/firm shall employ adequate number of scavengers and conservancy staff to maintain the latrines and urinals in a clean condition.

Two sheds one for meals and the other for rest shall be provided separately for the use of men and women workers and properly maintained.

All the above amenities shall be provided at the contractor's/firm's own expenses besides providing sheds for his/their workmen.

### **59. Patent Rights**

The Contractor shall save harmless and indemnify the Employer from and against all claims and proceedings for or on account of infringement of any patent rights, design trademark or name or other protected rights in respect of any Contractor's Equipment, material or Plant used for or in connection with or for incorporation in the Works and from and against all damages, costs, charges and expenses whatsoever in respect thereof or in relation thereto.

### **60. Royalties**

Except where otherwise stated, the Contractor shall pay all seignorage and other royalties, rent and other payments or compensation, if any, for getting stone, sand, gravel, clay or other materials required for the Works.

### **61. Old Curiosities**

All old curiosities, relics, coins, minerals and any other item of archeological importance found at the site shall be the property of the Government and shall be handed over to the Engineer in charge for depositing to the Government exchequer. Should any structure be uncovered, the instruction of the Engineer in charge shall be provided before demolition or removal of the structure.

### **62. Contractor Dying, becoming Insolvent or Insane**

In the event of death or insanity of the contractor, the contract may be terminated by notice in writing, pasted at the site and advertised in the issue of the local newspaper. All acceptable works shall thereafter, be paid at appropriate rates after recovering all the

contractor's dues to Employer, to the persons entitled to receive and give a discharge for such payments.

In the contractor is imprisoned because insolvent compound with his creditors has a receiving order made against him or carriers on business under receiver for the benefit of the creditors of any of them or being a corporation goes into liquidation or commences to be wound up not being a voluntary winding up for the purpose only of amalgamation or reconstruction, the employer shall be at liberty.

- a) To give such liquidator, receiver or other persons in whom the contract may become vested the option of carrying out the contract or a portion thereof to be determined by the employer, subject to his providing an appropriate guarantee for the performance of such contractor.
- b) To terminate the contract forthwith by notice in writing to the contractor the liquidator, the receiver or person in whom the contract may become vested and take further actions as provided in the clause pertaining to default by contractor, treating as if this termination is ordered under the respective clause.

### **63. Force Majeure**

The works taken by the contractors under the contract shall be at the contractor's risk until the work is taken over by the Project Engineer. The contractor shall arrange his own insurance against fire, flood, volcanic eruption, earth quake and other convulsions of nature and all other natural calamities, risks arising out of acts of god, Acts of Terrorism, Civil disturbances, Riots during such period and that the OWSSB/Government shall not be liable for any loss or damages occasioned by or arising out of any such acts of God.

Provided however that the contractor shall not be liable for all or any loss or damages occasioned by or arising out of acts of foreign enemies, invasion, hostilities or war like operations (before or after declaration of war) rebellion military or usurped power.

### **64. Payment out of Public Funds**

The payments to the contractor/firm shall be made out of the funds under the control of the Employer in their public capacity and no member or officer of the Employer shall be personally responsible to the contractor/firm.

### **65. Bribery and Collusion**

In the event of the contractor offering or giving any official of the employer, any gift or consideration of any kind as an inducement or regard for doing, or for bearing to do, any action in relation to obtaining or in the execution of the contract or any other contract with the employer, or for showing favour to any person in relation to the contract or any other contract with the employer, or if any of the such acts shall have been done by any person employed by the contractor or acting on his behalf, either with the knowledge of the contractor or not which are all grounds for the employer to terminate the contract awarded to the contractor. Similarly, if the contractor colludes with another contractor or number of contractors whereby an agreed quotation or estimate shall be offered as a bid, that will also form the basis for the employer to terminate the contract.

## **66. Technical audit**

It is a term of this contract that department shall have the right to carry out post payment audit and technical Audit by the Engineers of Technical audit cell (or by an approved consultant of repute). The Technical audit officer shall have the powers to inspect the work or supply running account bill, final bill and other vouchers, measurement books, test reports and other documents either during progress of work or after completion of the same and order recoveries from the contractor for recorded reasons even though the contractor might have been paid earlier. These recoveries are enforceable against the contractor from any amount due to him, from performance security or withheld amounts or any amounts due to the contractor or may become due to him from the department in any work or supply.

## **67. Settlement of dispute**

### **a. Dispute Redressal Committee**

In order to ensure a dispute Redressal mechanism, a Committee headed by .....  
OWSSB for each package in order to resolve any disputes between the Employer / Engineer – in charge concerned and the contractor

### **b. Jurisdiction of Court**

**In the event of non-settlement of any dispute by the Dispute Redressal Committee arising between the parties hereto in respect of any matter comprised in the contract, the same shall be settled by a competent court having jurisdiction over the place where the contract is awarded and agreement is concluded and by no other court.**

## **68. Reservation of Right**

The Employer reserves the right to accept or reject any or all the bids and to annul the entire process of bidding at any time. Under such circumstances, the Employer will neither be under any obligation to inform the bidders of the grounds for the action of the Employer nor the Employer will be responsible for any liability incurred by the bidder on this account.

**SPECIAL CONDITIONS OF CONTRACT****Construction period of the contract – 9 Months****Trial run of the scheme – 3 Months**

1. The Contractor shall, except as stated below, be responsible for the provision of all electricity power, water, gas, consumables, chemicals and other services he may require. During Trial run of the Works, the **Contractors shall be responsible for the provision of all water, gas, consumables, chemicals, other services and all spares and tools** not listed in Schedule of Technical Particulars T11 but actually be required for the Works. **The electricity power cost as related to the normal operation and maintenance and trial run of the Works shall be borne by the Contractor.**

Unless otherwise stated in the Conditions of Particular Applications of the Works, monthly progress reports shall be prepared by the Contractor and submitted to the Engineer in six copies. The first report shall cover the period up to the end of the first calendar month following the commencement date of that Section. Reports shall be submitted monthly thereafter, each within 7 days after the last day of the period to which it relates.

Reporting shall continue until the Contractor has completed all works which are known to be minor outstanding at the completion dates stated in each of the Taking-Over Certificate of the Works.

**Each report in trial run of the Works shall include:**

- (a) Photographs showing status of each equipment, plant, civil structures at all sites of the Works;
- (b) Logs to show the maintenance record to all equipment;
- (c) Logs to show the replacements of damage and defective components of each equipment or the whole equipment of a Plant;
- (d) Logs to show the attendance records of all the operation and Maintenance staff; and
- (e) Comparisons between the recommendations from the Operation and Maintenance Manual with the actual maintenance, defective parts replacement records as described in (c) and (d) above.

**2. Contractor's Operations on Site:**

Upon the issue of the Taking-Over Certificate of the Works, the Contractor will be handed over the whole Works by the Employer such that the whole Work will be under possession by the Contractor. The Contractor shall be responsible for all works that are required for possession of the whole Works.

**3. General Design & Obligations:**

The requirements to As-Built Documents of the Works are described in Part A – General Specification of the Contract. The requirements to Operation and Maintenance Manuals of the Works are described in Part A – General Specification of the Contract.

The Contractor shall allocate his operation and maintenance staff at the Works every day to conduct operation and maintenance work to the Works, in multiple shifts, with details as specified in the Employer's Requirement Facilities for Staff and Labour Save insofar as the Contractor may otherwise provide, the Contractor shall provide and maintain such accommodation and amenities as he may consider necessary for all his staff and labour, employed for the purposes of or in connection with the Contract, including all fencing, water supply (both for drinking and other purposes), electricity supply, sanitation, cookhouses, fire prevention and firefighting equipment, cookers, refrigerators, furniture and other equipment in connection with such accommodation or amenities. On completion of the Contract, unless otherwise agreed with the Employer, the temporary camps/housing provided by the Contractor shall be removed and the site reinstated to its original condition, all to the approval of the Engineer.

**4.Reservation of Right**

The Employer reserves the right to accept or reject any or all the bids and to annul the entire process of bidding at any time. Under such circumstances, the Employer will neither be under any obligation to inform the bidders of the grounds for the action of the Employer nor the Employer will be responsible for any liability incurred by the bidder on this account.

**LETTER OF NEGOTIATION**

In pursuance of negotiation with the Executive Engineer/Superintending Engineer/Chief Engineer of Division/Circle/Region on

I/We agree to reduce the rates for the items in the BoQ as follows.

| Sl.No. | Item No. In the BoQ | Reduced rate/unit |
|--------|---------------------|-------------------|
|--------|---------------------|-------------------|

Signature of Contractor



**ORISSA WATER SUPPLY AND SEWERAGE BOARD**

Forwarding Slip to The Lump sum Agreement No.

1. Name of Work :
- Estimate Amount :
- Sanctioned in Original Estimate No. :
- Revised Estimate No. :
2. Name of Contractor and Address :
3. Original or Supplemental :
4. If Supplemental, Original Agreement No. :
5. Approximate value of work :  
to be done under this Agreement :
6. If this is Supplemental, approximate value of  
works to be done under Original  
Agreement :
7. If bids have been called for, is the lowest :  
tender accepted?  
If not reasons to be recorded
8. Has the contractor; signed the divisional :  
copy of TNBP and Its addenda volume  
brought up to date.
9. Is data furnished for all items of works :  
noted in the Schedule
10. Are the rates in Agreement within the :  
estimate rates or schedule of rates whichever  
is less and the Lump sum provision sufficient or  
likely to be exceeded.

**II. Additional Information****A. Original Agreement**

1. Original Agreement amount of tender excess: and percentage over the estimate rate.
2. If concessional rate of EMD & SD have :  
been allowed ref. to sanction thereof

**B. Supplemental Agreement**

1. Whether the approval of the competent :  
authority has been obtained for the rates as  
required.
2. If entrusted without tenders whether sanction:  
is necessary with reference to total value of  
work covered by the supplemental agreement  
so far accepted.

**ORISSA WATER SUPPLY AND SEWERAGE BOARD**

Form of Agreement (Lump sum)

Articles of Agreement made this-----

Day of -----

between M/s-----

\_\_\_\_\_  
\_\_\_\_\_  
\_\_\_\_\_

hereinafter referred to as the contractor which expression shall where the context so admits include his heirs, executors, administrators and legal representatives of the one part and the Orissa Water Supply and Sewerage Board (hereinafter called the Employer) which expression shall where the context so admits include its successors in office and assigns) of the other part. Whereas the contractor delivered to the Employer the bid which was opened on -----

-----  
-----whereby the contractor offered and undertook to carry out the works specified under this contract and allied work, i.e. (name of work) -----  
-----  
-----

In the State of Odisha in India, and provide the works, materials matters and things described or mentioned in these presents at the prices set forth in the schedule annexed to such bid and the contractor also undertook to do all extra and varied works which might be ordered as part of the contract on the terms provided for in the conditions and specifications hereto annexed and the Employer accepted such tender in pursuance where of the parties hereto have entered into this contract.

And whereas the contractor in accordance with the terms of the said Bid has deposited in the Office of the Project Engineer, OWSSB ----- as performance security for the due and faithful performance by the contractor of this contract, the sum of Rs. ----- (Rupees -----)

And whereas the contractor fully understands that on receipt of communication of acceptance of bid from the accepting authority, there emerges a valid contract between the contractor and the Employer represented by the Officer accepting the agreement and the bid documents, i.e. invitation for bids, letter of application, bill of quantities and other schedules, general conditions of the contract, technical specifications of the bid, negotiation letter, communications of acceptance of bid, shall constitute the contract for this purpose and be the foundation off rights of both the parties, as defined in clause 8.1 of ""Bid Documents ""Now hereby agreed that in consideration of payment of the said sum of Rs. (Rupees) or such other sum as may be arrived at under the clause of the General conditions of the contract relating to payment by final measurement at unit prices, the contractor shall and well within the time specified in his bid thoroughly and efficiently and in a good workman like manner perform, provide, execute and do all the works, materials matters of things incidental to or necessary for the entire completion of the works specified under this contract and necessary works

including all works shown in the drawings hereinafter referred to or described or set forth the said specifications and schedule hereto annexed and in accordance with such further drawings and instructions as the Engineer of the Board or other Engineer duly authorised in that behalf (therein after) and in the annexed documents referred to as the Engineer) shall at any time in accordance with the said schedule (Bill of Quantities) and specifications provide and give together, with any alterations in the works or additions thereto, in the time and manner in such schedule (Bill of Quantities) and specifications stipulated to the entire satisfaction of the Engineer, the Employer for themselves and their successors convenient and agree with the Contractor that during the progress of the works and on the completion of contract to the satisfaction of the Engineer, the Employer shall and will from time to time on receiving the certificates in writing of the Engineer pay to the contractor according to such certificates and the terms of this contract the price or sum mentioned in such certificates as due to the contractor under the terms of this contract subject nevertheless to deductions or additions thereto or there from which may be lawfully made under terms of his contract. It is hereby mutually agreed and declared as follows.

- a) All certificates or notice or orders for items or for extra varied or altered works which are to be the subject of an extra or varied or altered works charge shall be in writing whether so described in the contract or not and unless in writing shall not be valid or binding or be of any effect whatsoever.
- b) The term contract includes these presents and the invitation for bid, bid documents, bill of quantities and other schedules, general conditions and specifications hereto annexed and the plans drawings herein and hereafter referred to.
- c) If the contractor claims that the decisions or the instructions of the Employer are unjustified and that accordingly, he is entitled to extra payments on account thereof he shall forthwith notify this to the Employer to record his decisions and reasons there for in writing and shall within two weeks state his claims in writing to the Employer thereafter. The Employer shall thereafter within four weeks of the receipt of the claim, reply to the points raised in the claim. Unless resolved by negotiation or discussions immediate thereafter, within further four weeks the question of liability for such payment will be treated as a dispute.
- d) In the contract whenever, there is as discretion or exercise of will, by the Employer during the progress of the work, the mode or manner of the exercise of discretion shall not be a matter for dispute.
- e) The decision of the Employer shall be final conclusive and binding on all, Parties to the Contract upon all questions relating to the meaning of specifications, designs, drawings and instructions, and as to the quality of workmanship or material used on the work or any matter arising out of or relating to the specifications, designs and drawings and instructions concerning the works or the erection of or failure to execute the same arising during the course of works. The above shall not be the subject matter of dispute and in no case shall the work be stopped consequent on such a dispute arising and the work shall also be carried out by the contractor strictly in accordance with the instructions of the Employer.
- f) In case any question, difference or dispute shall arise on, matters other than clauses (d) and (e) above and except any of the "excluded matters" mentioned in bid documents

touching the construction of any clause herein contained on the rights, duties and liabilities of the parties hereto or any other way touching or arising out of these presents, the same shall.

- i) In the event of any dispute arising between parties here to in respect of any of the matter comprised in this contract, the same shall be settled by a competent court having jurisdiction over the place where contract is awarded and agreement is concluded and by no other court.
- ii) Provided always the contractor shall not except with the consent in writing of the Engineer in any way, delay carrying out works in any such matter, question or dispute being referred to court but shall proceed with the works with all the diligence and shall until the decision of the Employer and no award of Competent Civil Court shall relieve the contractor of his obligations to adhere strictly to the instructions of the Engineer with regard to the actual carrying out of the works.
- g) Time shall be considered as essence of the contract and the contractor hereby agree to commence the work immediately after taking over of site or signing the agreement whichever happens earlier, complete the work within -----months and to show progress at the stipulated milestone.

In witness where of the contractor and the Employer on behalf of the Board have caused their common seal to be affixed the day and year first above written Signed, sealed and delivered by the said.

Signature of Contractor Signed by on behalf of

OWSSB.

Name and Seal.

Signature, Name and Designation of Witness Designation of Witness.

Signed, Name and

### INDEMNITY BOND

This deed of indemnity bond executed at (place) on this Day of (month)year by and between M/s / Sri. (Name)

widow/Wife/Son/Daughter of Sri / Smt residing at (Full Address) (hereinafter called "Contractor" which expression unless excluded by or repugnant to the context include his/her heirs, executors administrators and legal representatives) to and in favour of OWSSB (hereinafter called" the Engineer, which expression shall unless excluded by or repugnant to the context include its successor and assigns) represented by the Project Director of Circle / Project Engineer of PMU shown as follows;

2. Whereas the contractor has submitted the bid for Septage treatment Plant in Sambalpur Town in Sambalpur District - Septage Treatment Plant in Sambalpur Town in Sambalpur District, Odisha - Construction of Settling-thickening tanks, Sludge drying beds, Anaerobic Baffled Reactors, Horizontal planted gravel filter, Maturation pond, Filtrate sump, Security room, CC pavement, construction of compound wall around the treatment plant, Effluent disposal arrangement, Construction of Pump Room of 12 m<sup>2</sup>, supply, delivery and installation of Non clog submersible pump sets, laboratory room, watch shed, administrative room etc. complete including Trial run for 3 Months (period of completion - 9 months ) and such bid has been accepted subject to the relevant conditions to contract appended to Odisha Building Practice and other conditions issued along with bid documents.

3. And where as in pursuance of the terms of contract, that a sum equal to **two and half** % of the total value of work done have been retained with the Employer for a period of two years reckoned from the date of completion of the work in order to enable the departmental officers to watch the effect of all seasons on the work and the structural stability of the work executed by the contractor.

4. And whereas it was decided to refund the said sum equal to **two and half** % of the total value of the work done retained with the Employer on the expiry of two years period reckoned from the date of completion of work provided that the contractor execute an indemnity bond for a period of three years indemnifying the Board against any loss or expenditure incurred to rectify any defect noticed due to the faulty workmanship by the contractor or substandard material used by the contractor during the period of three years.

5. Now this deed of indemnity witness that in consideration of the contract entrusted to the contract or by the Employer, the contractor has agreed to the following terms and conditions and executed this indemnity bond in conformation of all and undertakes to comply with the terms referred to infra.

6. The contractor both hereby indemnify the Employer against any loss or damage that may be caused to the Employer in respect of rectification of any defect noticed due to the faulty workmanship by the contractor, or substandard material so used by other contractor in the execution of work entrusted to the contractor during the period of three years i.e. from up to (dates to be specified)

7. It is hereby confirmed that in all other respects, the agreement conditions will be binding between the parties.

In witness whereof Sri / Smt / Ms

Contractor has signed this deed on this day      of month      year.

Witness:

**INDEMNITY BOND**

(In lieu of water tightness and structural stability)

To accompany the Lump sum agreement No.

This deed of Indemnity made this day of \_\_\_\_\_ between  
 Sri \_\_\_\_\_ S/o \_\_\_\_\_ (hereinafter called  
 contractor "which expression shall unless excluded by or repugnant to the context include his heir/executors, administrators and legal representatives) and in favour of the Orissa Water Supply and Sewerage Board (hereinafter called the Employer which expression shall unless excluded by or repugnant to the context include its successors and assigns) represented by the Project Director, OWSSB / Project Engineer, PMU, OWSSB, Cuttack as follows;

Whereas the contractor agreed to construct a reinforced cement concrete Water Retaining Structures including pipe connections as per departmental plan and designs under SeTP Project Rs. (Rupees ) as per Lump Sum Agreement No./ and two of the conditions of the said agreement are;

1. That the contractor should reduce a water tight structure and guarantee its water tightness for two years as per clause in Form in General conditions of contract, definitions and interpretations.

2. That in lieu of the 40% (Forty percent) of the amount of each bills scheduled to be withheld from the payment and kept with the Employer with security deposit till the expiry of the above guarantee period and till a certificate of soundness of structure is furnished by **the Project Engineer, PMU, Sambalpur, OWSSB** the contractor has agreed to execute an Indemnity bond vide clauses in Form in General conditions of contract, definitions and interpretations of Lump Sum Agreement No.

And whereas the Employer has agreed to accept a deed of Indemnity from the contractor in lieu of 40% (Forty percent) of the amount of each bill to be withheld from payment.

Now these present witness that in pursuance of the above said agreement and for the consideration above said, the contractor hereby agrees with the Employer that he will at all times indemnify and keep harmless of the Employer as a result of the failure of the contractor to remedy or to replace any failure or defects in the water tight structure for a period of two years from the date of commissioning which includes maintenance period of one year.

The contractor further agree with the Employer that on receipt of the report of the Engineer in charge about any failure or defects noticed in the structure within a period of two years from the actual date of commissioning and handing over to the Employer after Trial run period .A joint inspection has to be made immediately by the Engineer of the contractor and the Engineer in charge of SeTP in Sambalpur Town and if in the opinion of the **Project Engineer, PMU, Sambalpur, OWSSB** the failure or defects noticed are due to the defects in the structure (construction) the contractor undertakes to rectify or replace immediately the structure at contractor's cost and the contractor agrees to extend the guarantee period for two more years from the date of rectification of the defects.



The contractor further agrees with the Employer that in the case of any dispute arising between the contractors on one hand and the Project Engineer, PMU, Sambalpur, OWSSB on the other hand as to any matter relating to the defects or failure noticed in the structure and the contractor's guarantee for water tightness for a period of two years from the accepted date of completion of the structure as indicated above such dispute shall be referred to the Member Secretary, OWSSB, Satyanagar, Bhubaneswar, whose decision shall be final. In witness whereof Sri .....

..... S/o .....

District and the Project Director / Project Engineer, PMU, Sambalpur, OWSSB acting on behalf of OWSSB have hereunto set their hands on the day and the year first written above.

Signature Signature

Name: Name:

Seal: Seal

**PERFORMANCE BANK GUARANTEE (UNCONDITIONAL)**

**To**  
**The Project Engineer,**  
**PM Unit, Cuttack**

----- (Name of Employer) -----  
----- (Address of Employer)

WHEREAS ----- (name and address of contractor) (hereinafter called" the contractor" has undertaken, in pursuance of contract No.-----  
--- Dated ----- to execute----- (name of contract and brief description of works) hereinafter called " the contract\*\*"

AND WHEREAS it has been stipulated by you in the said contract that the contractor shall furnish you with a Bank Guarantee by a recognised bank for the sum specified therein, as security for compliance with his obligations in accordance with the contract.

AND WHEREAS the contractor has requested us to give the Bank Guarantee

AND WHEREAS we have agreed to give the contractor such a Bank Guarantee unconditionally and irrevocably to guarantee as primary obligator and not as mere surety, all the payments to the -----  
-----

NOW THEREFORE we hereby affirm that we are the Guarantor and responsible to you, on behalf of the contractor, up to a total of ----- (amount of Guarantee) -----  
----- (amount in words such sum being payable in the types and proportion of currencies in Which the contract price is payable, and we undertake to pay you unconditionally and Irrevocably upon your first written demand and without cavil or argument, any sum or Sums within the limit of -----  
----- (amount of Guarantee) as aforesaid Without you needing to prove or to show grounds or reasons for your demand for the Sum specified therein.

We hereby waive the necessity of your demanding the said debt from the contractor before presenting us with the demand.

We further agree that no change or addition to or other modification of the terms of the contractor or of the Works to be performed there under or of any of the contract documents which may be made between you and the contractor shall in any way release as from the liability under this guarantee and we hereby waive notice of any such change, addition or modification.

The Bank Guarantee is drawn at \_\_\_\_\_branch of \_\_\_\_\_bank in \_\_\_\_\_Town in Odisha only.

This guarantee shall be valid until 28 days from the date of expiry of the defects liability period.

**SIGNATURE AND SEAL OF THE GUARANTOR**

Name of Bank \_\_\_\_\_

Address \_\_\_\_\_

\_\_\_\_\_

Date \_\_\_\_\_

**BID SECURITY (BANK GUARANTEE)**

WHEREAS, \_\_\_\_\_ *[name of Bidder]* (hereinafter called "the Bidder") has submitted his Bid dated \_\_\_\_\_ *[date]* for the construction of \_\_\_\_\_ *[name of Contract]* (hereinafter called "the Bid").

KNOW ALL PEOPLE by these presents that We \_\_\_\_\_ *[name of bank]* of \_\_\_\_\_ having our registered office at \_\_\_\_\_ (hereinafter called "the Bank") are bound unto \_\_\_\_\_ *[name of Employer]* (hereinafter called "the Employer") in the sum of \_\_\_\_\_<sup>1</sup> for which payment well and truly to be made to the said Employer the Bank binds itself, his successors and assigns by these presents.

SEALED with the Common Seal of the said Bank this \_\_\_\_\_ day of \_\_\_\_\_ **2016**.

THE CONDITIONS of this obligation are:

1) If after Bid opening the Bidder withdraws his bid during the period of Bid validity specified in the Form of Bid;

or

2) If the Bidder having been notified of the acceptance of his bid by the Employer during the period of Bid validity:

- (a) fails or refuses to execute the Form of Agreement in accordance with the Instructions to Bidders, if required; or
- (b) fails or refuses to furnish the Performance Security, in accordance with the Instruction to Bidders; or
- (c) does not accept the correction of the Bid Price pursuant to Clause 28.2;

we undertake to pay to the Employer up to the above amount upon receipt of his first written demand, without the Employer having to substantiate his demand, provided that in his demand the Employer will note that the amount claimed by him is due to him owing to the occurrence of one or any of the three conditions, specifying the occurred condition or conditions.

This Guarantee will remain in force up to and including the date \_\_\_\_\_<sup>2</sup> days after the deadline for submission of Bids as such deadline is stated in the Instructions to Bidders or as it may be extended by the Employer, notice of which extension(s) to the Bank is hereby waived. Any demand in respect of this guarantee should reach the Bank not later than the above date.

DATE \_\_\_\_\_ SIGNATURE OF THE BANK

WITNESS \_\_\_\_\_ SEAL \_\_\_\_\_

[signature, name, and address]

1 The Bidder should insert the amount of the guarantee in words and figures denominated in Indian Rupees. This figure should be the same as shown in Clause 16.1 of the Instructions to Bidders.

2 45 days after the end of the validity period of the Bid.

